

# Mikasa

CONCRETE CUTTER

# MCD-T18H-PLUS

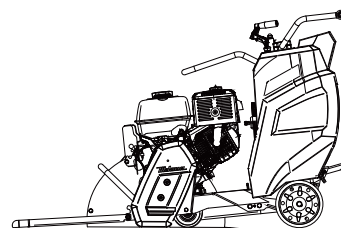

## OPERATION MANUAL

en



<http://www.mikosas.com>

602-02901



# TABLE OF CONTENTS

1. INTRODUCTION .....	1
2. MACHINERY OVERVIEW .....	1
3. WARNING SIGNS .....	2
4. CAUTIONS FOR SAFETY.....	2
4.1 General Cautions	2
4.2 Precautions Refueling	3
4.3 Precautions Of Location And Ventilation	3
4.4 Precautions Before Starting	3
4.5 Precautions During Work	3
4.6 Precautions Of Lifting	4
4.7 Precautions Of Transport And Storage	5
4.8 Precautions Of Maintenance	5
4.9 Decals Position	6
4.10 Decals List	7
4.11 Descriptions Of Warning Decals	7
5. APPEARANCE .....	9
6. SPECIFICATIONS .....	11
7. INSPECTION BEFORE OPERATION .....	12
7.1 Engine Oil	12
7.2 Fuel	12
7.3 Water Tank	12
7.4 Belt	13
7.5 Lifting/Lowering	13
7.6 How to Read Cut Depth	14
7.7 Installing the Blade	15
7.8 Parking Brake	15
7.9 Stop Switch	15
8. OPERATION .....	16
8.1 Starting	16
8.2 Operation	17
8.3 After Operation	18
9. STOP .....	18
10. TRANSPORT .....	19
10.1 Loading And Unloading	19
10.2 Transporting	19
11. STORAGE .....	19
12. INSPECTION AND MAINTENANCE .....	20
12.1 Inspection and Maintenance Schedule	20
12.2 Grease Up	21
12.3 Handle Adjustment	21
13. TROUBLESHOOTING .....	22
13.1 Engine	22
13.2 Main Body	23

## 1. INTRODUCTION

- This operation manual describes the proper operation, basic inspection and maintenance procedures of the concrete cutter. Please read this operation manual before use in order to maximize the excellent performance of this machine and make your work more efficient and effective.
- After reading the manual, please keep it in a handy location for easy reference.
- For the handling the engine, please refer to the separate engine operation manual.
- For inquiries about repair parts, parts lists, service manuals, and repairs, please contact the store where you purchased the product, our sales office, or the Mikasa Parts Service Center.
- For parts lists, please visit our homepage (<https://www.mikasas.com>) where you can access Mikasa WEB parts lists.

The illustrations in this manual might slightly differ in part from the machine you actually purchased due to design changes.

## 2. MACHINE OVERVIEW

### Application

Mikasa Concrete Cutter is used to cut the concrete or asphalt road surface by Diamond Blade that is attached on its Blade shaft. Please choose machine type by cutting depth, and then choose appropriate blade to match the spot situation, such as material age, presence or absence of reinforcement in the concrete.

### Warning About Incorrect Applications And Techniques

Use this machine to cut plain concrete, reinforced concrete and asphalt only.  
Do not cut sediment, for that it flies into pieces and injuries man around the machine.  
This cutter can be equipped with diamond blade only. Do not attach resin bond blade and dry type blade on this machine.  
Make sure to sprinkle water to the blade when cutting to prevent conglutination of the blade or chips of blade breaks into pieces. Do not use this machine with blade speed more than specified blade speed, so that conglutination of the blade or chips of blade breaks into pieces. Do not use this machine on an unstable or rough ground, for that conglutination of the blade or chips of blade breaks into pieces. Do not use this machine to cut a secondary product concrete.

### Structure





Engine of Concrete Cutter is fixed on a main body base, and conveys power to Blade shaft with the Ribbed belt. The way of adjustment of Ribbed belt tension is making Engine slide.  
Belt cover, Handle guide, Handle for elevating the blade, and Blade cover which can be put on and off easily is attached on Engine Base. Cutting depth is adjusted by rotating Handle for elevating the blade through Blade Arm that is equipped with Front wheel The way to travel the machine is pushing the machine directly.  
Cooling system of blade is the centrifugal injection type with the forced sprinkling water generated by the centrifugal pump attached on the blade shaft.

### Power Transmission

Air-cooled petrol engine is amounted on Mikasa Concrete Cutter as power source.  
Pulley is attached on Engine shaft for driving Blade shaft, and Diamond Blade is attached on Blade shaft. The cutting depth can be adjusted to change the Front wheel position by Handle.  
The way of driving the machine while cutting is pushing the handle.

### 3. WARNING SIGNS

The triangle shaped  marks used in this manual and on the decals stuck on the main body indicate common hazards. Be sure to read and observe the cautions described.

 <b>Warning labels indicating hazards to humans and to equipment.</b>	
 <b>DANGER</b>	Denotes an extreme hazard. It calls attention to a procedure, practice, condition or the like, which, if not correctly performed or adhered to, is likely to result in serious injury or death.
 <b>WARNING</b>	Denotes a hazard. It calls attention to a procedure, practice, condition or the like, which, if not correctly performed or adhered to, could result in serious injury or death.
 <b>CAUTION</b>	Denotes a hazard. It calls attention to a procedure, practice, condition or the like, which, if not correctly performed or adhered to, could result in injury to people and may damage or destroy the product.
<b>CAUTION</b> (without at  )	Failure to follow the instructions may result in damage to property.

### 4. CAUTIONS FOR SAFETY

#### 4.1 General Cautions

##### **WARNING**

- Do not work with this machine, when
  - you are tired or sick and not feeling well,
  - you have taken medicine or drug, or
  - you have had a drink.



##### **CAUTION**

- Read this instruction manual carefully and handle the machine as described so that you can work safely.
- For details about the engine, refer the separate instruction manual for the engine.
- Make sure you thoroughly understand the construction and operation of the machine.
- Please check each part before work, and execute the scheduled check and alignment regularly.
- To work safely, always wear protective clothing (helmet, safety glasses, safety shoes, ear plugs etc.) and appropriate work clothes.
- Please wear Hearing protector ( noise protective equipment of ear muff or ear stoppers) by all means.
- Always check the machine to make sure that it is normal before starting operation.
- The decals on the machine body (operating methods, warning decals, etc.) are very important to ensure safety. Keep the machine body clean so that they can be read at all times. If any decal cannot be read, replace it with a new one.
- It is very dangerous if children come into contact with the machine. Take the utmost care how and where the machine is stored.
- Before performing any maintenance, be sure to turn the engine off.
- Mikasa does not accept any liability for accidents or problems caused as a result of not using genuine Mikasa parts or if the machine has been modified.



## 4.2 Precautions Of Refueling

### **DANGER**

- Always refuel in a well ventilated area.
- Make sure to stop the engine and wait until the engine cools down when refueling.
- Select a flat surface area with no flammable material around for refueling. Be careful not to spill the fuel. Wipe off well if there is any spill.
- Never put fire near the machine during refueling. (Especially, be careful about smoking.)
- If you refill to the top of the fuel tank inlet, fuel might spill out from the tank, and it becomes dangerous
- After refueling, tighten the tank cap well.

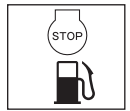

## 4.3 Precautions Of Location And Ventilation

### **DANGER**

- Do not run the machine in an unventilated location, such as indoors or inside a tunnel. The exhaust gas from the engine contains toxic gases such as carbon monoxide and is very hazardous.
- Do not operate the machine near open flames.



## 4.4 Precautions Before Starting

### **CAUTION**

- Check the fixing condition of each parts. Cause the big failure that does not think that a screw loosens by vibration. Tighten the screw well.
- Confirm that the diamond blade does not have anomaly such as deficit of the blade chip or the crack of the board.
- If the machine were not run more than 3 months, be sure to start at low speed in a few minutes to warm up thoroughly, for the reason to avoid engine seizure by oil film shortage.

## 4.5 Precautions During Work

### **CAUTION**

- When starting and working with the machine, confirm that neighboring people and obstruction are safe.
- Always pay attention to foothold and work in easy position that allow to keep your machine in good balance.
- Be careful not to touch muffler and engine body as it becomes hot in operation or just after operation.
- Discontinue operation promptly whenever your machine goes deficient or you notice any abnormality.
- Be sure not to make the cutter with blade stand-by for work.  
In the case to be without avoidance, be sure to run the engine at low speed possibly in a short time.  
(In case of running the engine at high speed at the above position for long time, it might occur the engine seizure by oil film shortage.)
- Be sure to stop engine before leaving the machine. Also shutdown engine for transporting the machine, and close the fuel cock.
- Mount blade cover by all means, and use it.
- Because engine turns blade when start, be careful enough. Do not bring legs close especially.
- Be careful enough so that be not rolled up your hand or clothes in reel (inside of the belt cover).



## 4.5 Precautions During Work

### **⚠ DANGER**

#### **Precautions in inclined area**

**When you use machine on inclined area, various risk is accompanied. Adhere rigidly to the following precautions to a minimum, and try for further safety retention. When you cannot get safety, never use it.**

- Do not leave machine in the inclined area. There is danger to cause a serious accident when machine begins to move by any chance.
- In the inclined area, grasp a handle well, and never separate a hand from machine. Machine begins to move in tare weight at the moment when you separated a hand, and there is danger to cause a serious accident.
- When you work in inclined area, be located in the upper part of the slope for machine by all means, and let machine face straight it below for a slope, and work.
- Stop the machine at flat space. When you stop machine in inclined area out of necessity, lower straight machine after having stopped the engine by all means, do wheel stopper to the front wheel for safe retention by all means. When be collided by an automobile and be shaken in right and left, even if you put on wheel stopper down the front wheel, the machine climbs wheel stopper and begins to move, and be careful this risk is very likely. Even if you put on wheel stopper down the back wheel, there is not effect. In addition, a parking brake of the rear wheel is not a thing to guarantee certain fixation of the machine. Use wheel stopper for a front wheel on the occasion of a stop by all means.
- When put wheel stopper, never go in the front side of the machine. When machine has begun to move by any chance. There is the danger of serious injury or decease, by the physical truncation with blade and the conflict of machine.
- If hand touches the blade when put wheel stopper, there is danger injured seriously. Put wheel stopper from the non blade cover side of the machine by all means.
- In case of stop, when water is in the water tank, the center of gravity rises and the balance worsens. Even if you put wheel stopper to the front wheel at the time, it is very dangerous that the front wheel climbs over wheel stopper and begins to move. In this case pull water out of the water tank by all means.
- When a road surface gets wet in inclined area, wheel stopper in itself slips depending on an angle, and effect is gone. Stop on the dry road surface by all means, when you stop it in inclined area out of necessity.
- Do not work on blade installation disassembly in inclined area, because it is dangerous.
- Do not work on to cross the slope. There is danger that tumble of the machine or the damage of the blade cause a serious accident.

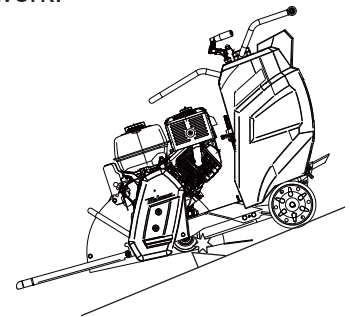

## 4.6 Precautions Of Lifting

### **⚠ DANGER**

- Be sure to work with sling by crane license holder.
- Before work of lifting, check any damage of body parts (especially, Lifting hook, etc) or looseness / omission of screws, and be sure safe.
- Stop the engine at the time of the lifting, and close the fuel cock.
- Use enough strength of wire rope.
- The work of lifting uses only one-point lifting hook, and do not lift in other point (handles).
- Never put any person or animal under the lifted machine.
- For safety, do not lift up the machine more than required height.



## 4.7 Precautions Of Transport And Storage

### **WARNING**

- Stop the engine at the time of transportation.
- Carry it after engine and body got cold well.
- By all means drain fuel before transporting the machine .
- Fix the machine well not to move and fall down.

## 4.8 Precautions Of Maintenance

### **CAUTION**

- Appropriate maintenance is always required for safety operation and to maintain performance of the machine. Pay full attention in the condition of the machine, and maintain good condition. Especially improper maintenance of lifting-related part becomes cause of serious accident.
- Lower the temperature of the machine before working. Especially muffler becomes high temperature, and there is danger that burn itself. In addition, be careful not to burn itself enough, because engine or engine oil become hot.
- Do the alignment check when the engine is stopped. There is badly injured danger when you are caught in the rotating parts.
- Check the installation of safety protection parts and safety of the machine after maintenance. Especially, bolts and nuts should be thoroughly checked.
- When you do maintenance with assembling and disassembling, refer to maintenance manual regularly, and work safely.



## 4.9 Decals Position

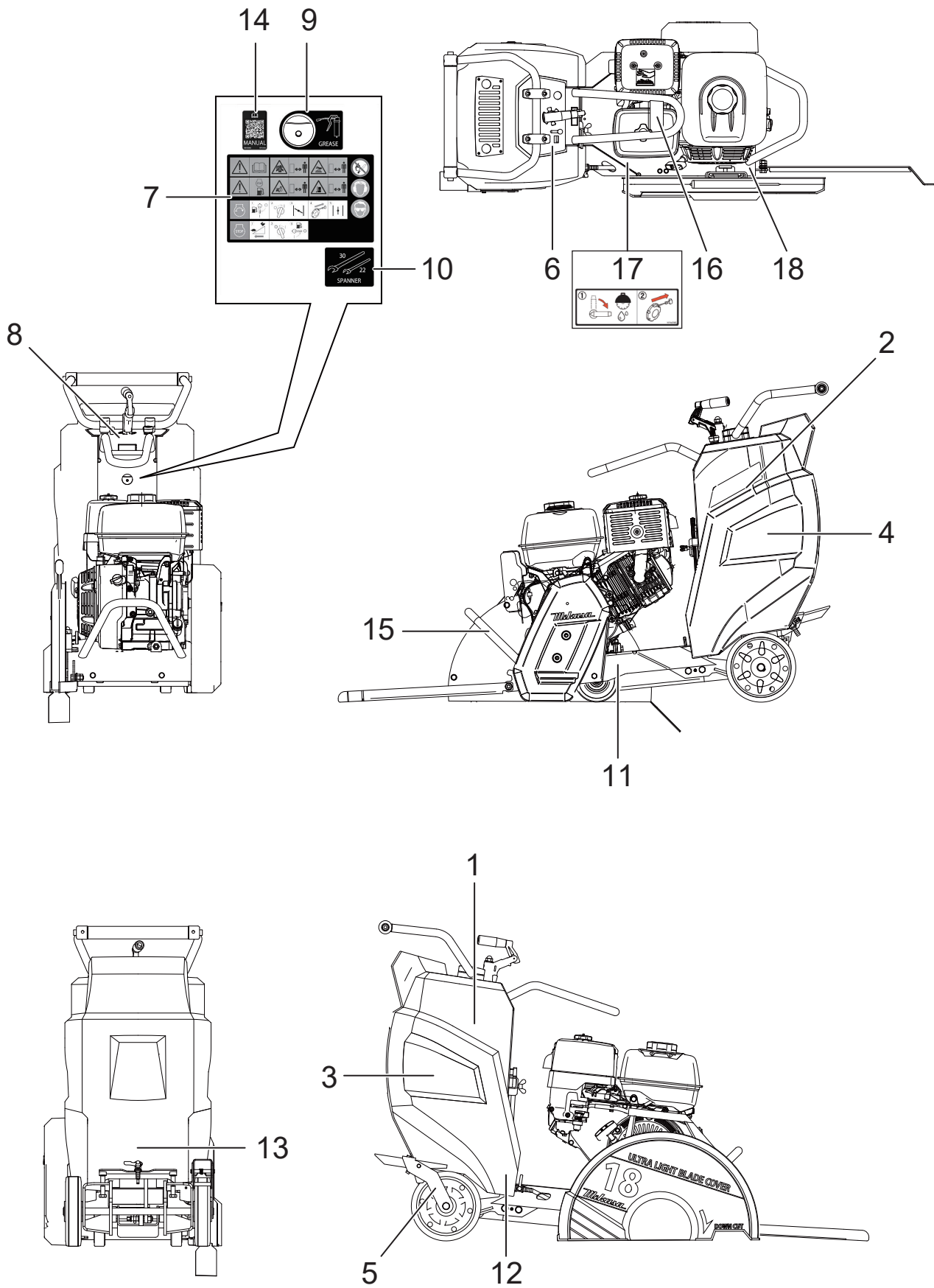



## 4.10 Decals List

No.	Part No.	Part Name	Q' TY	Decal No.	REMARKS
1	9202-26000	DECAL, MIKASA LOGO(R)/T18HPL	1	NPA-2600	MCD-T18H-PLUS
2	9202-26020	DECAL, MIKASA LOGO(L)/T18HPL	1	NPA-2602	MCD-T18H-PLUS
3	9202-26010	DECAL, MODEL LOGO(R)/T18HPL	1	NPA-2601	MCD-T18H-PLUS
4	9202-26030	DECAL, MODEL LOGO(L)/T18HPL	1	NPA-2603	MCD-T18H-PLUS
5	9202-24130	DECAL, BRAKE /MCD-T18	1	NPA-2413	
6	9202-24140	DECAL, INSTRUMENT PANEL/T18	1	NPA-2414	
7	9202-24150	DECAL, CAUTIONS SET /T18	1	NPA-2415	
8	9202-24160	DEACL, TACHO METER /T18	1	NPA-2416	
9	9202-24170	DEACL, GREASE /MCD-T18	1	NPA-2417	
10	9202-24180	DEACL, SPANNER /MCD-T18	1	NPA-2418	
11	9202-24190	DEACL, BELT /MCD-T18	1	NPA-2419	
12	9202-24200	DEACL, WATER COCK /T18	1	NPA-2420	
13	9202-24210	DEACL, DRAIN WATER /T18	1	NPA-2421	
14	9202-24820	DEACL, MANUAL(QR)/EN/T18	1	NPA-2482	
15	9202-14730	DECAL, DO NOT LIFTING	1	NPA-1473	
16	9202-14740	DECAL, LIFTING POSITION	1	NPA-1474	
17	9202-25830	DECAL, SPRINKLING WATER/T18HPL	1	NPA-2583	MCD-T18H-PLUS
18	9202-26120	PLATE, SERIAL.NO/EXP/T18HPL	1	NPA-2612	MCD-T18H-PLUS

## 4.11 Descriptions Of Warning Decals

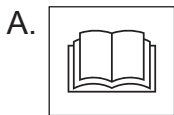
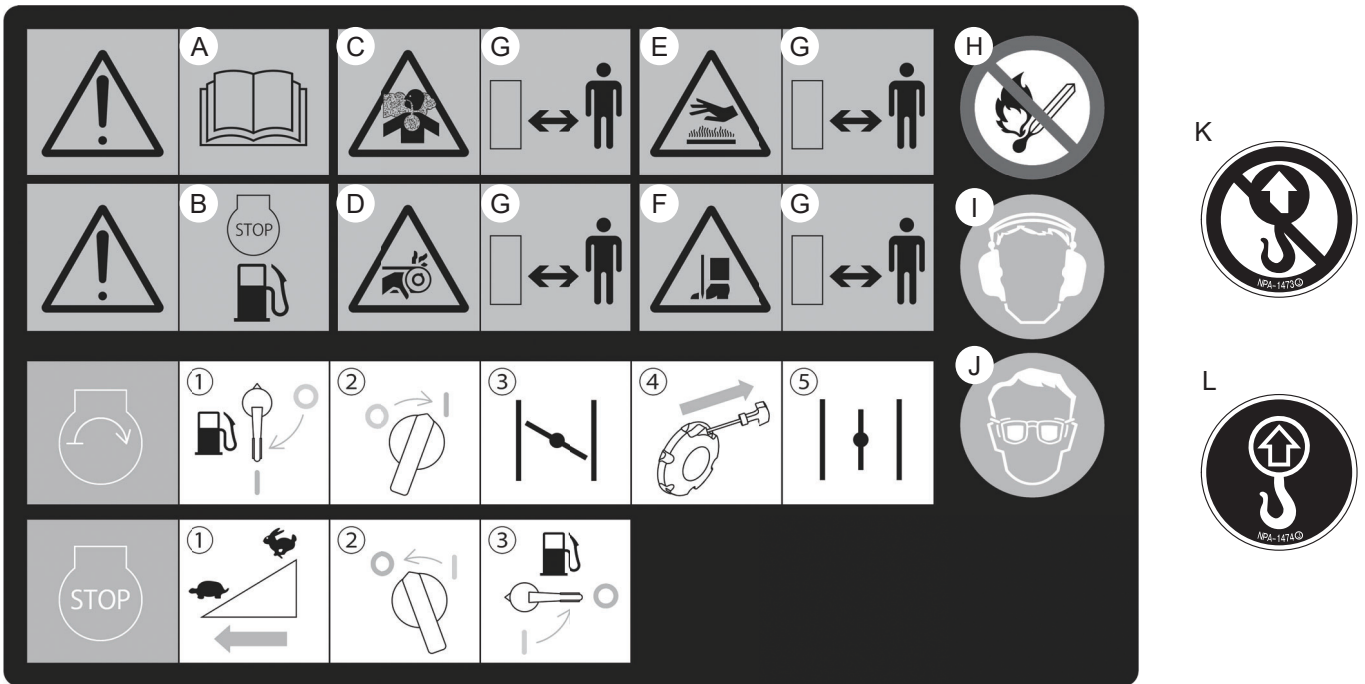

**A. Read the manual carefully.**  
Read and fully understand the operation manual before operating the machine.

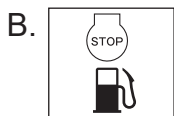

**B. Refueling Hazard.**  
Stop the engine and let cool before refueling.



**C. Lethal Exhaust Gas Hazard.**  
Carbon monoxide poisoning may occur if the exhaust gas is inhaled. Do not operate the machine in a poorly ventilated area.



**D. Rotating Parts Hazard.**  
Keep hands clear from all moving parts (such as inside the belt cover) to prevent injury.



**E. Burn Hazard.**  
Never touch the hot parts. Allow these parts to cool before servicing the machine.



**F. Blade hazard.**  
Keep feet clear from blade to prevent injury.

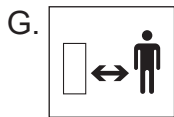

**G. Keep safe distance.**  
Be careful not to approach danger source during operation.



**J. Eye hazard.**  
Always wear eye protection while operating the machine.



**H. Fire hazard.**  
Keep away any flames and sparks from the machine.



**K. No lifting position.**  
Do not use any other points (such as the handle) except one point lifting hook for lifting the machine.



**I. Noise hazard.**  
Always wear ear protection while operating the machine.



**L. Lifting position.**  
Use one point lifting hook for lifting the machine.

## Starting and stopping for gasoline engine

### START

- ① Open Fuel Valve to start.
- ② Turn Stop Switch to "I"(ON) position.
- ③ Close Choke Lever.
- ④ Pull Recoil Starter to start the engine.
- ⑤ Return Choke Lever to open.

### STOP

- ① Return Throttle Lever fully until "O"(OFF) position to stop work.
- ② After cooling down enough, turn Stop Switch to "O"(OFF) position to stop the engine.
- ③ Close Fuel Valve at the end.

## Priming water

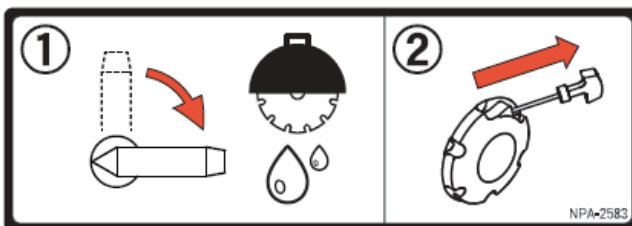

- ① Open Water Valve for the priming water before starting the engine.
- ② Start the engine after checking that the priming water comes out from side of blade.

## 5. APPEARANCE

### 5.1 Dimensions (mm)

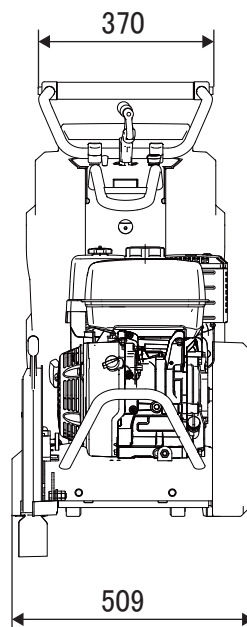
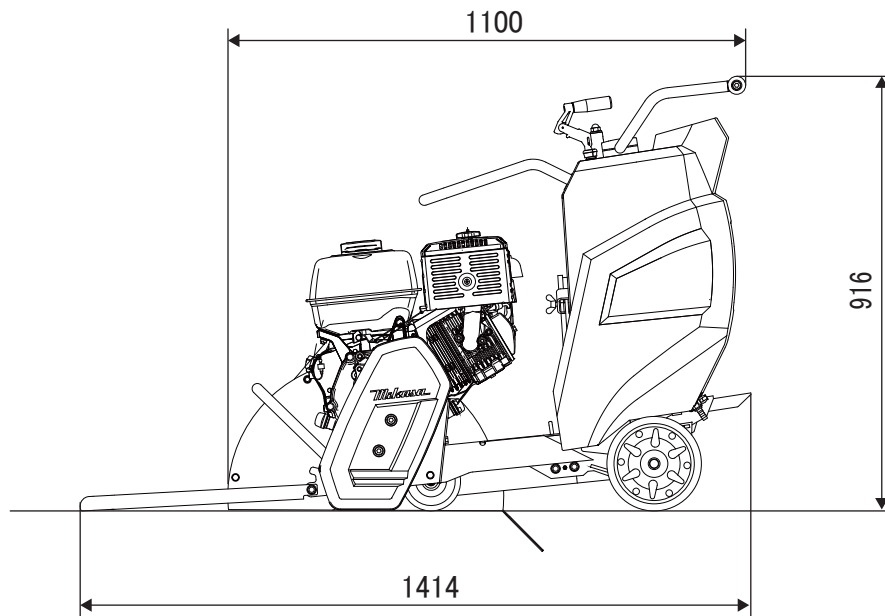

## 5.2 Components

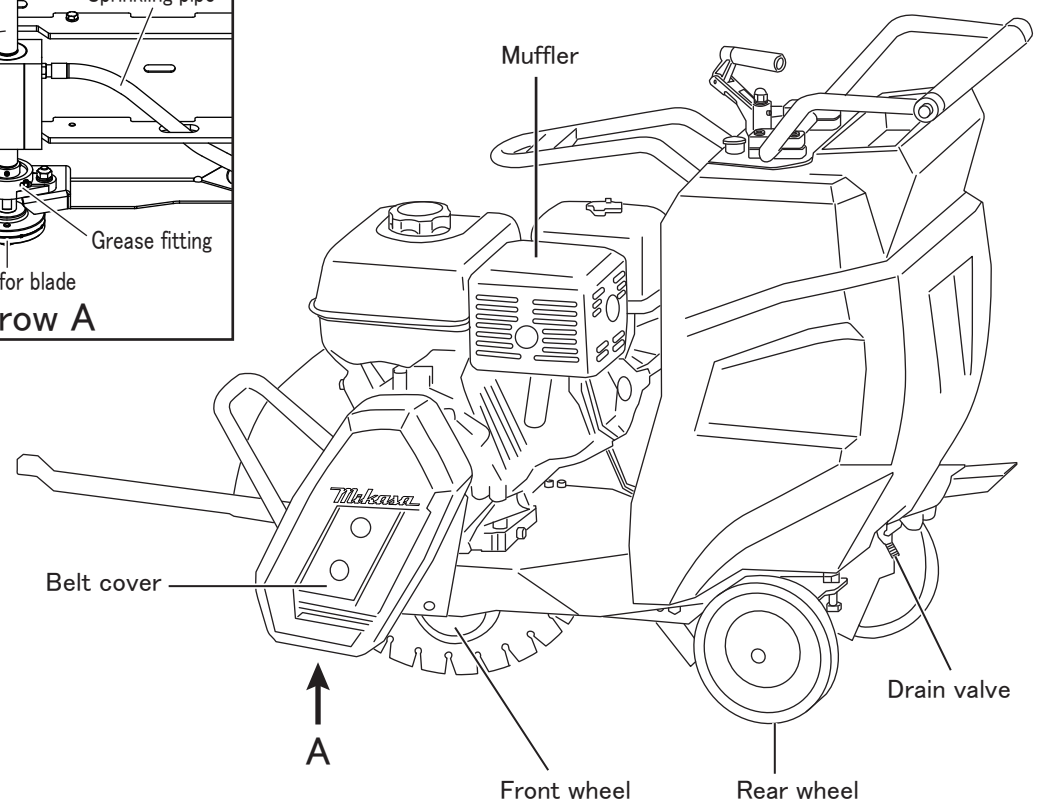
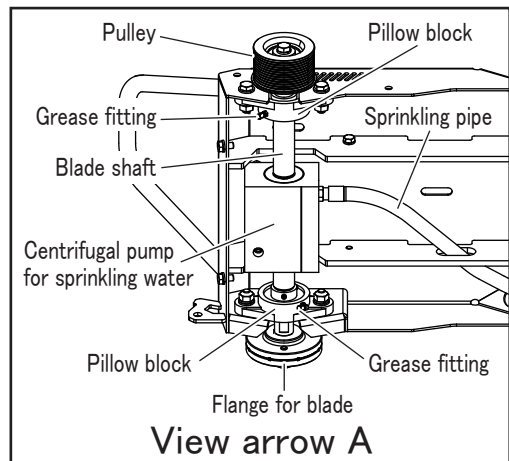
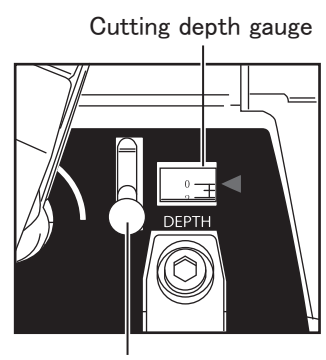
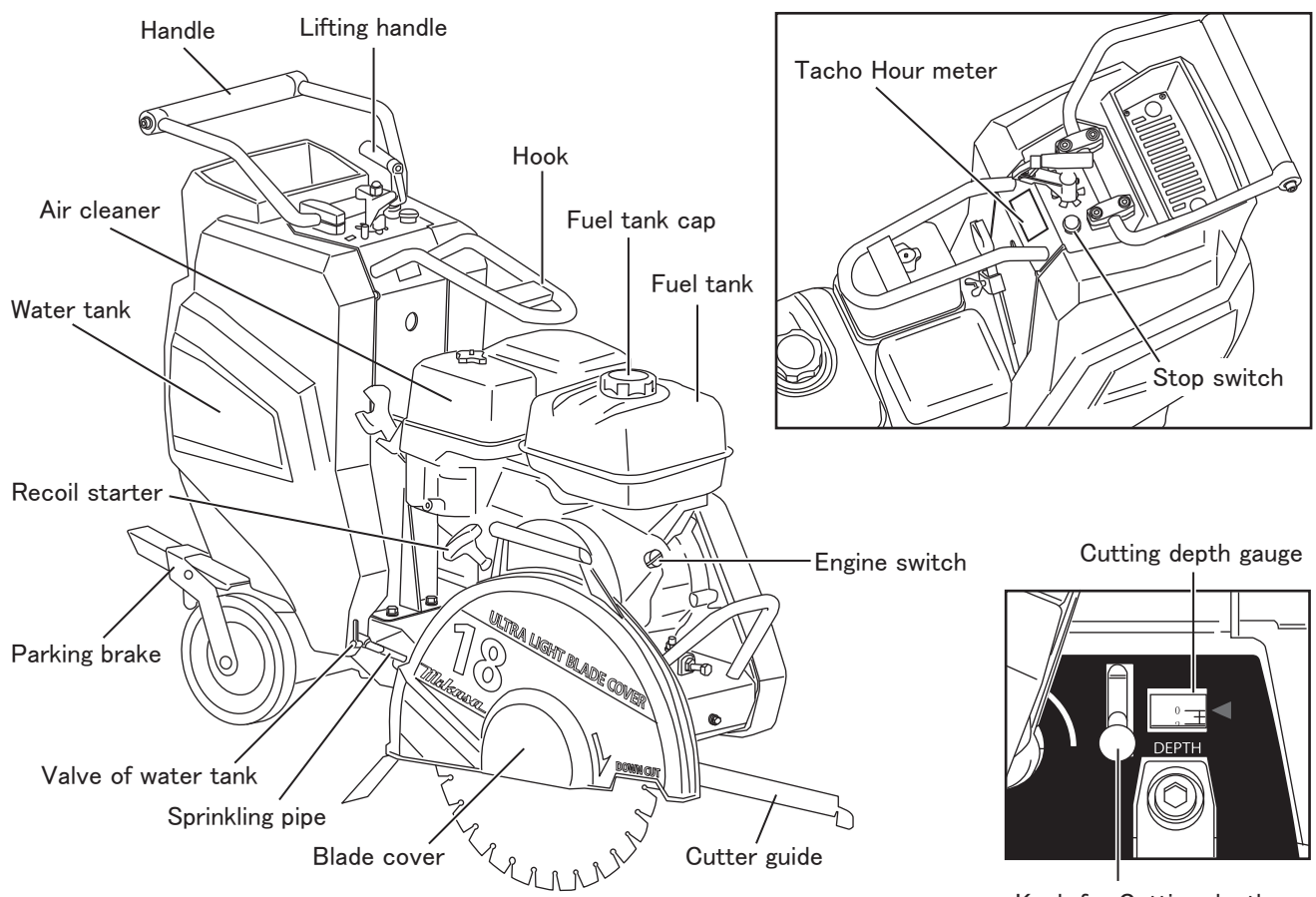

## 6. SPECIFICATIONS

### 6.1 Main Body

Model	MCD-T18H-PLUS	
Power source	Honda GX390	
Dimensions (when main body is level)		
Overall Length (on operating)	1414 mm	
Overall Width	509 mm	
Overall Height	916 mm	
Weight	133 kg	
Traveling system	Push walk behind	
Adjusting for cutting depth	Manual lifting screw system	
Cooling system of blade	Centrifugal injection type	
Sprinkling water system	Forced sprinkling type	
Water tank capacity	50 liters	
Arbor size	Standard: 27 mm / Option: 25.4 mm (1 inch)	
Blade size and maximum cutting depth	Blade size (Outer diameter)	Maximum cutting depth
	(10 inch) 254 mm	70 mm
	(12 inch) 305 mm	95 mm
	(14 inch) 356 mm	120 mm
	(16 inch) 407 mm	145 mm
	(18 inch) 457 mm	170 mm
Limitation of Blade size	under 18 inch	

※ Weight includes weigh of machine, lubricants, 50% of fuel and 50% of water tank capacity.

※ Specifications are subject to change without notice.

### 6.2 Engine

Manufacturer	Honda
Model	GX390
Engine Type	Air-cooled, 4-stroke Gasoline
Max. Output	8.7 kW (11.8 PS) / 3600 rpm
Operating Engine Speed	3600 rpm
PTO Shaft	Metric
Starter	Recoil
Fuel Tank Capacity	6.1 liters
Engine Oil Grade	API SE or later SAE10W-30
Engine Oil Capacity	1.1 liters

※ Specifications are subject to change without notice.

## 7. INSPECTION BEFORE OPERATION

### ⚠ CAUTION

- Always stop the engine and allow it to cool before inspection and set the machine on hard and level ground.
- Level the machine, and check it after the machine confirmed that it does not move.

- The check point before the work see "each part check schedule list" mentioned in 21 pages.

### 7.1 Engine Oil

- Level the engine and check oil level with oil gauge. (Fig.1)
- Refill oil from port of oil gauge as needed.
- Use following oil (10W-30 is in use when shipped).
- When it is used in normal temperature, its consumption tends to increase . Pay additional attention at the time of daily check. As for quality of oil, be sure to use SE grade or better.
- Degraded quality or decreased quantity may induce damage.

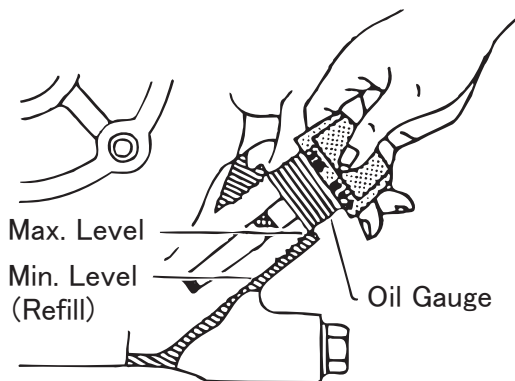

Temperature	Use oil
More than 25°C	SAE#30
10 ~ 25 °C	SAE#30, #20
10 ~ 0 °C	SAE#20
Less than 0 °C	SAE#10

Fig. 1

### 7.2 Fuel

- Visually check fuel level. If fuel level is low, refuel with unleaded fuel. (Fig. 2)
- When refueling, be sure to use a strainer for filtration.

### ⚠ DANGER

- Stop the engine when refueling.
- Never refueling near a naked flames or a source of sparks.
- Do not fill the fuel tank completely because the fuel might spill.
- Wipe up any spilled fuel.

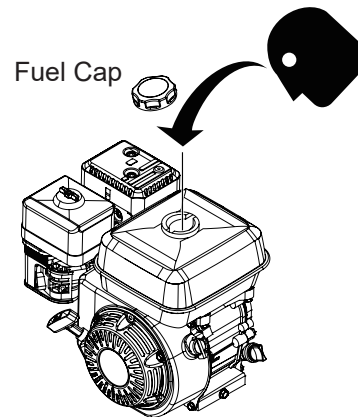

Fig. 2

### 7.3 Water Tank

- Refill the water tank with at least 50% over water. (Fig. 3)
- Check the water tank for leaks after refilling the water.
- Check the valve of water tank ON and OFF.
- Check that the priming water comes out from side of blade after ON the valve of water tank.

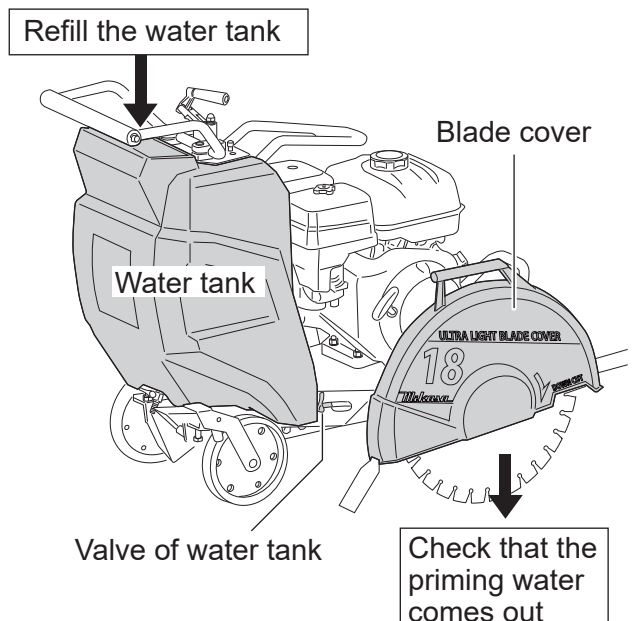

Fig. 3

## 7.4 Belt

### CAUTION

Check for bolts and nuts tightening after inspection.

#### ● Check the belt

Check the ribbed belt between engine and blade shaft for sag or defect. Tension is normal if the deflection is 4 -7 mm when depressed at midway between the two shafts. (Fig.4)

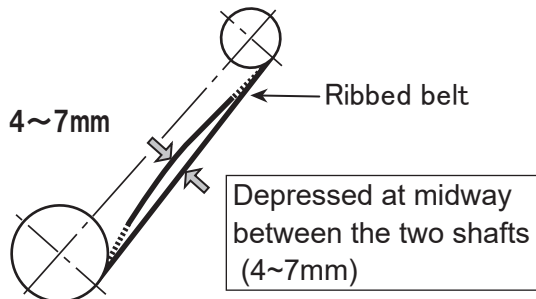
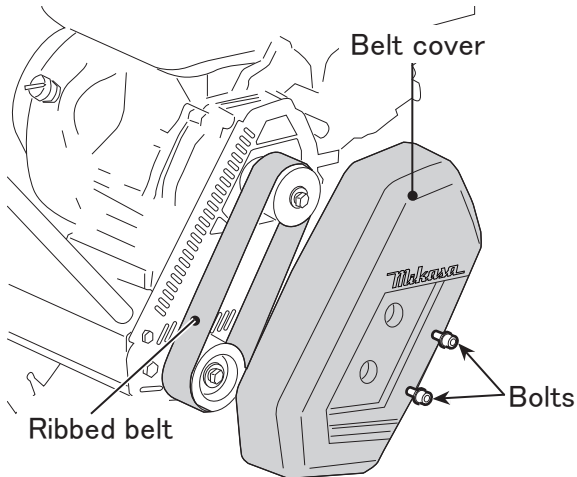

Fig. 4

#### ● How to adjust the belt

1. With 2 bolts removed, take off belt cover. (Fig.4)
2. Loosen 4 engine mounting bolts.

### CAUTION

Bolts should be just loosened, not removed.

3. Rotating "Adjust bolt & nut of belt tension" clockwise, the belt tension will be increased. (Fig.5)

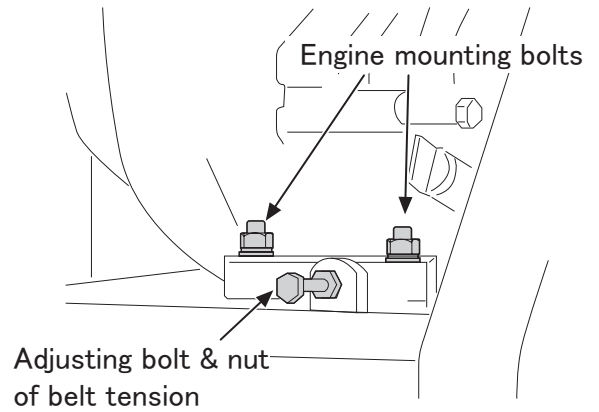

Fig. 5

#### ● How to replace the belt

1. Rotating "Adjust bolt & nut of belt tension" counter-clockwise to take off the belt easily.
2. Replace new belt and adjust the belt tension in accordance with the previous paragraph.

## 7.5 Lifting/Lowering

#### ● How to lift/lower the machine

Cutting depth can adjust with lifting handle. Rotating the lifting handle clockwise, machine body will ascend. And rotating it counter-clockwise, machine body will descend. When the lifting handle is released, it will be locked automatically. (Fig.6)

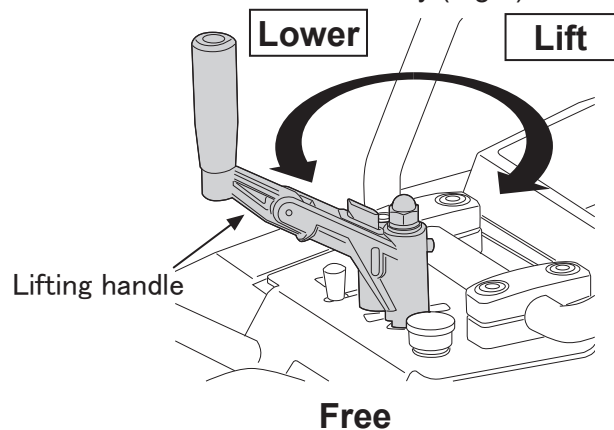

Free

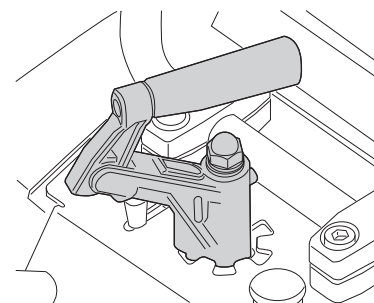

Lock

Fig. 6

● **How to adjust the lifting force**  
*After taking off the water tank, it can be adjusted with the bolt inside the frame.*

- Drain water from tank.
- Loosen bolts and nuts below the tank. And take off the flat-bar and water tank. (Fig. 7)

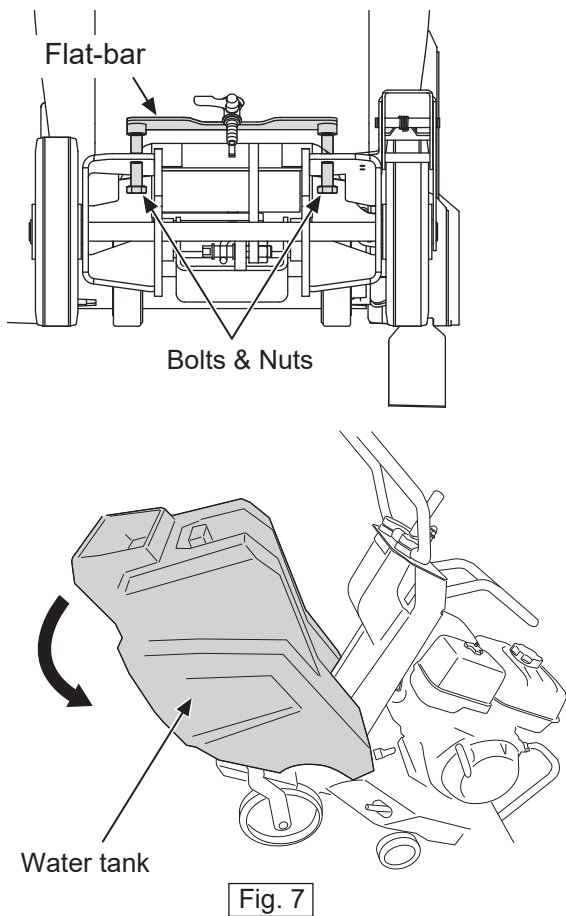

- Turning the adjusting bolt clockwise will reduce the force required to turn the handle to ascend the machine.
- Turning the adjusting bolt counterclockwise will reduce the force required to turn the handle to descend the machine.

※ **Ascending force and descending force should be equivalent.** (Fig. 8)

- After finishing the adjustment, tighten bolt & nuts to fix the water tank and flat-bar.

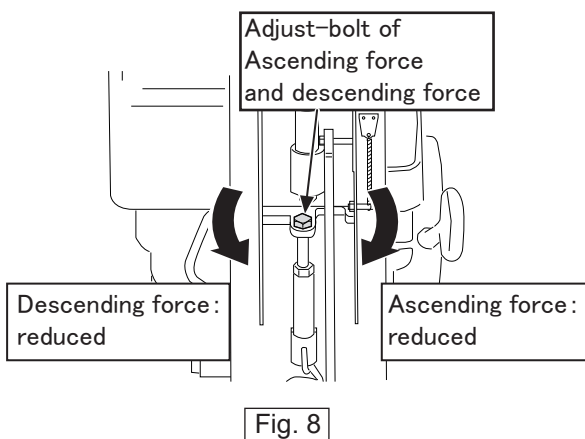

**7.6 How to Read Cut Depth**

● **Cutting depth refers to the distance between the blade periphery and the position directly below the blade axis, which is the center of rotation and is in contact with the ground surface.**

**Cutting depth gauge**

● The cutting depth gauge indicates the cutting depth at work. The cutting depth gauge is compatible with 14 to 18 inch blades and should be used with “the knob for cutting depth gauge adjustment” to adjust the position of the scale. (Fig.9)

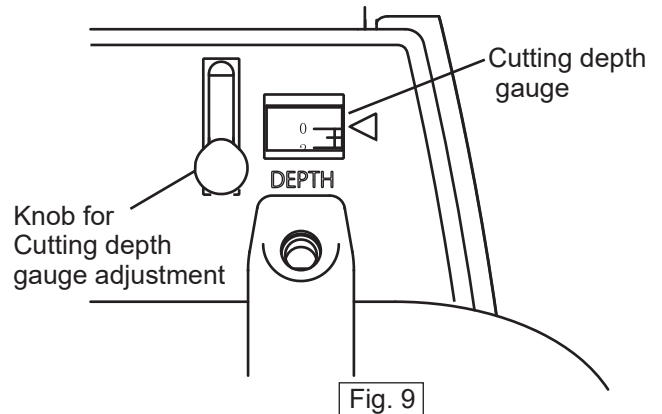

● **How to use cutting depth gauge (Fig. 7)**

- Set the gauge to Zero when the blade touch the ground surface.
- After started the cutting work, the cutting depth is indicated on the cutting depth gauge.

**CAUTION**

Every time you change the cutting site and/or blade, please adjust the cutting depth gauge with this method.

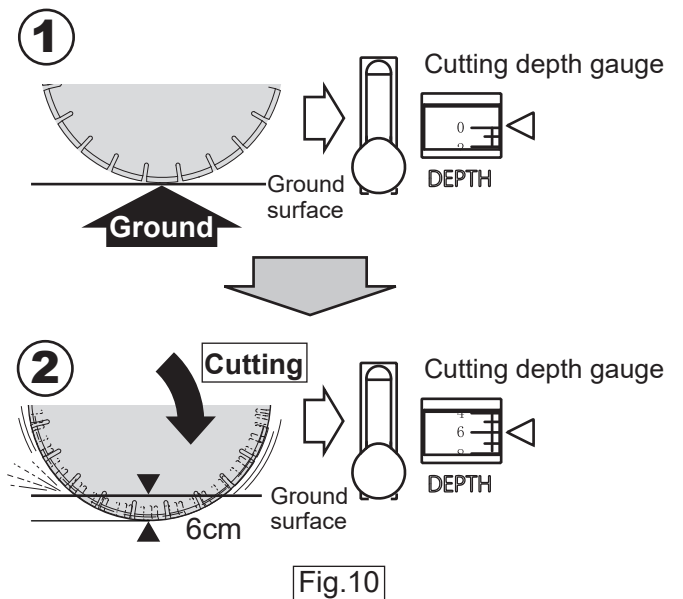



## 7.7 Installing the Blade

1. Install Flange (IN), Diamond Blade and Flange (OUT) in such order to the blade shaft and tighten sufficiently with Nut (left hand thread). (Fig. 11)

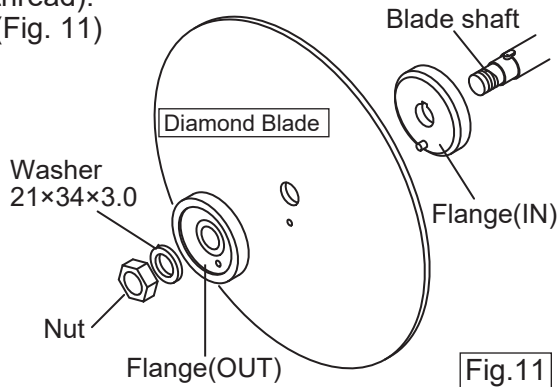

Fig.11

2. Standard accessory wrenches are used to tighten the nut. 30mm wrench is for the nut. And 22mm wrench is for fixing the arbor. (Fig.12)

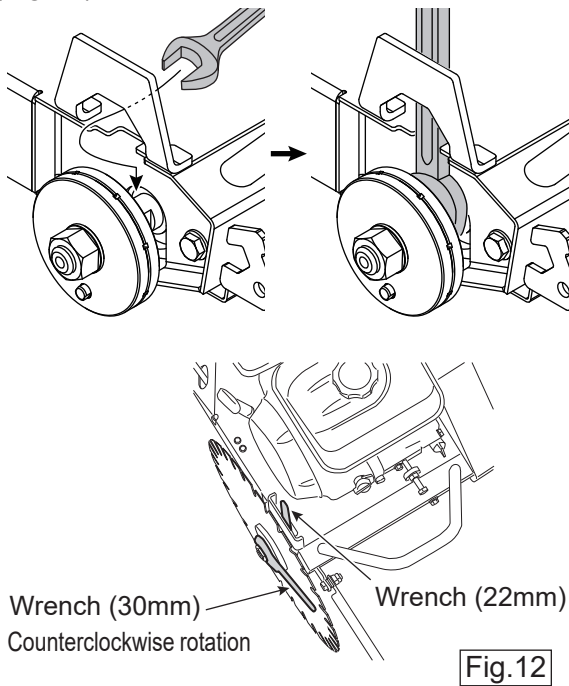

Fig.12

3. After blade has been tightened, check the cooling water and install blade cover.
4. Set the cutter guide, aligning it with the blade. (Fig. 13)

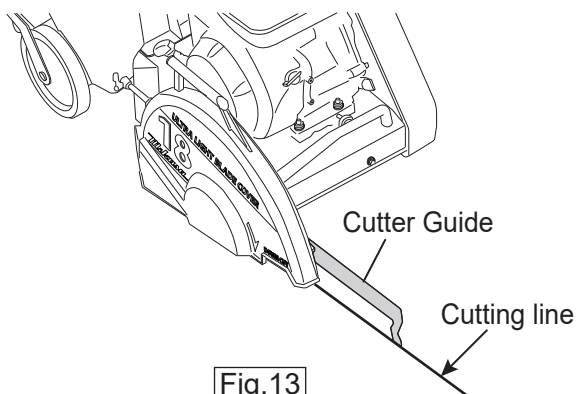

Fig.13

## 7.8 Parking Brake

- There is a Parking Brake on right rear wheel. The wheel will be locked when the brake lever pushed down. And the wheel will be unlocked when the brake lever pushed up. The brake should be unlocked before work. (Fig.14)

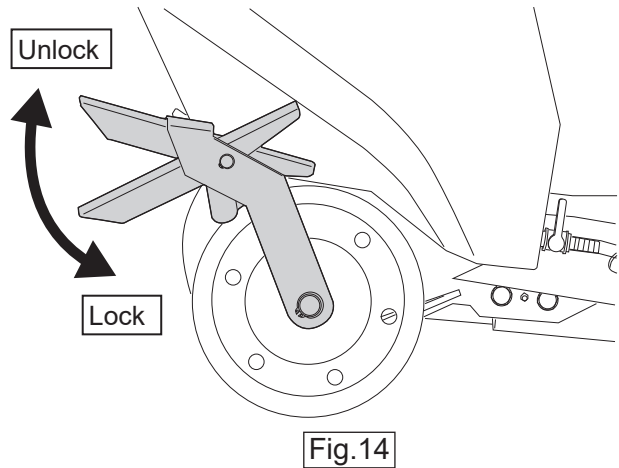

Fig.14

## 7.9 Stop Switch

- Stop Switch is equipped as standard for the safety. (Fig.15)
- a. *Stop*  
Push the stop switch to stop the engine. Then, the switch will hold the pressed down state.
- b. *Reset*  
The switch should be turned clockwise to reset the stop switch

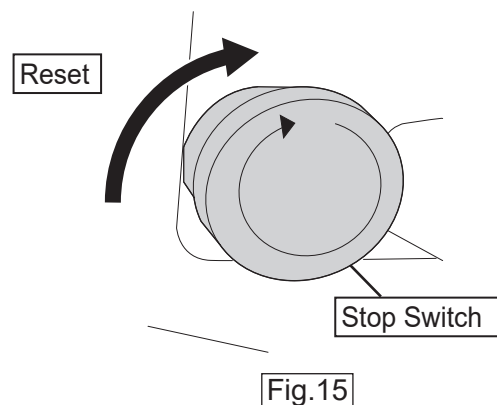
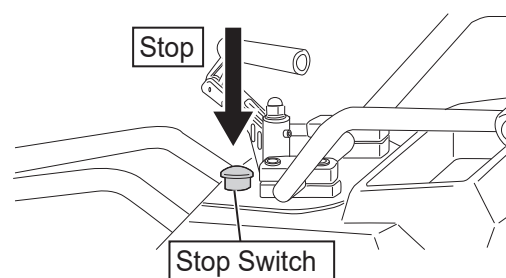

Fig.15

## 8. OPERATION

### CAUTION

- Do not start the engine without priming water.
- Follow the starting procedure. It may cause damage of oil seal of centrifugal pump or reduction of sprinkling water volumes.
- Do not keep to run the engine with water dose not come out from the side of blade.

### 8.1 Starting

1. Refill the water tank with at least 50% over water.
2. Turn the lifting handle clockwise until the blade is lifted to the maximum height. (Fig.16)

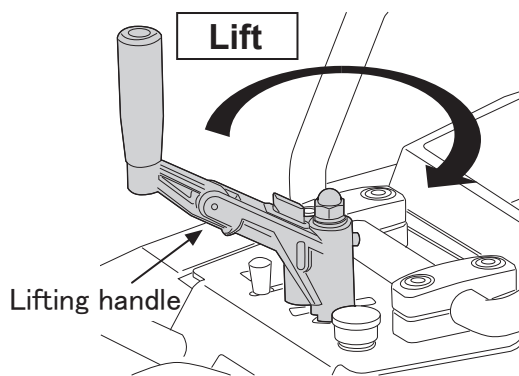

Fig.16

3. Open the valve of water tank and check that the priming water comes out from side of blade certainly. (Fig.17)

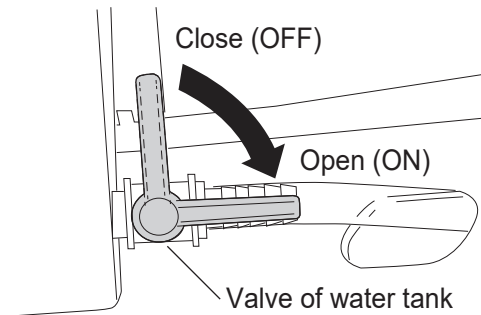

Fig.17

4. Keep to come out the priming water.
5. Set the fuel valve lever to the "ON" position to let the fuel flow. (Fig.18)

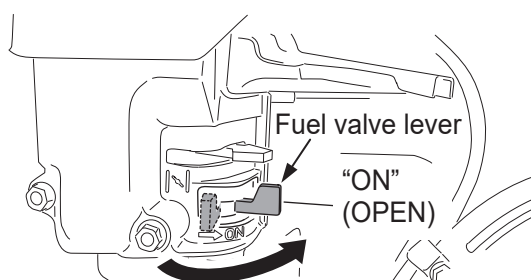

Fig.18

6. In cold weather or when the engine does not start easily, set the choke lever to the "Start" position. This is not necessary when the engine is already warmed up. (Fig.19)

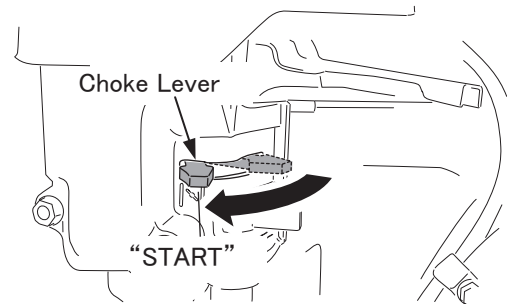

Fig.19

7. Turn on the engine switch on. (Fig.20)

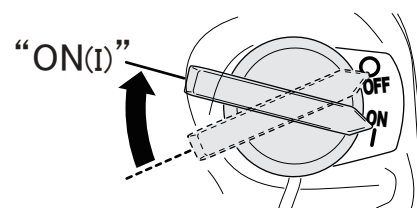

Fig.20

8. Hold the recoil starter grip, and pull it a little. You will feel a slight resistance. Then, pull it hard to run the engine. Be careful not to pull too hard, or the rope might break or come off. Allow the starter rope to slowly move back into the case while keeping the grip grabbed. (Fig.21)

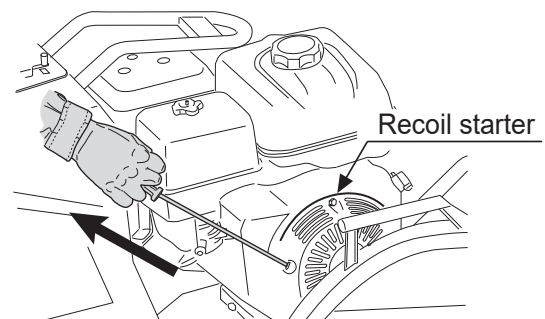

Fig.21

### CAUTION

- Do not pull the starter knob all the length of the rope.

**WARNING**

- Be very careful enough because the blade rotate when starting the engine at the same time.

9. When the engine is stopped, the tacho & hour meter is always shown "Operation time". During operation, it is shown "Engine speed". (Fig.22)

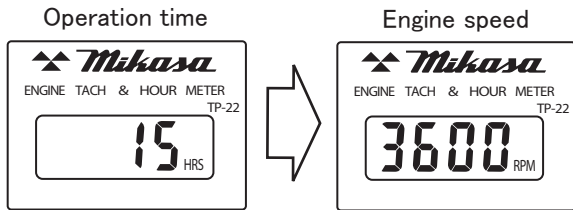

Fig.22

10. After engine has started, while listening to engine sound, slowly return the choke lever to OPERATION position. (Fig.23)

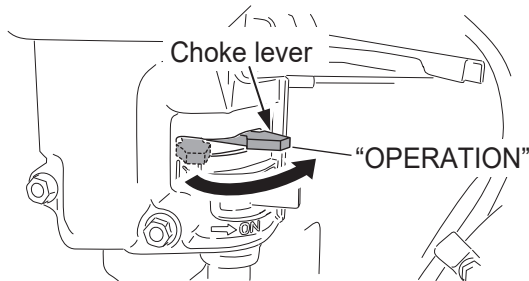

Fig.23

**8.2 Operation**

**CAUTION**

- Sudden cutting or impacting may cause damage of blade or ribbed belt, decrease durability of engine and etc.

1. Align the cutting guide with pre-determined cutting line. Aligning is easier if it is done with the machine lifted.
2. Move the throttle lever to the operating speed position slowly. (Fig.24)

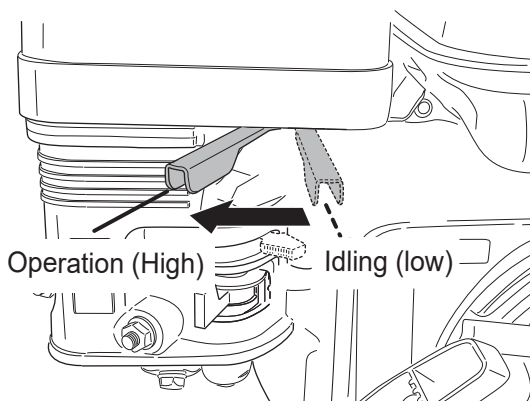

Fig.24

3. The amount of sprinkling water increases to the proper amount, as the engine speed increases.
4. To cut-in with the blade, turn the lifting handle counterclockwise, and cut down while adjustment the lowering speed so that engine speed is not reduced excessively. (Fig. 24)

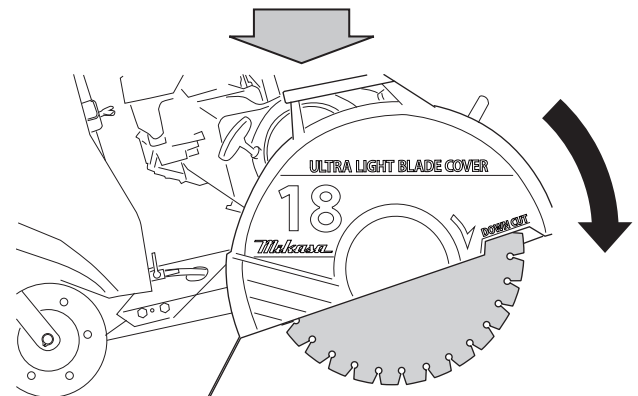
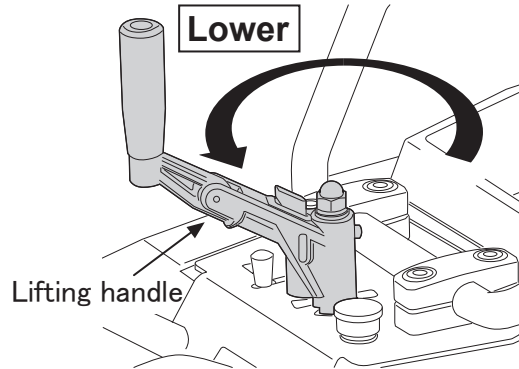
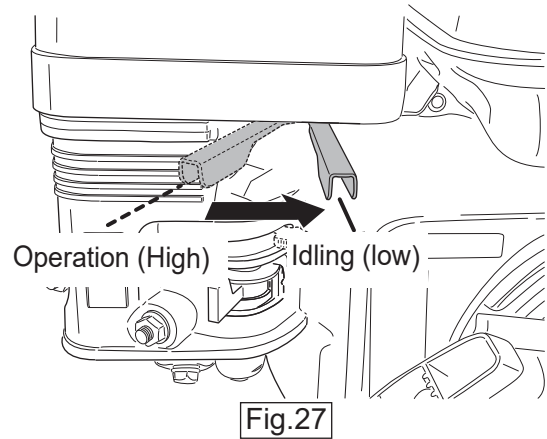
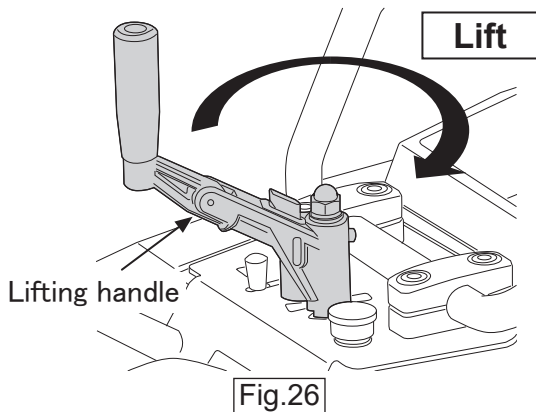

Fig.25

5. While checking the cutting depth with cutting depth gauge, control the cutting work. When the blade reach to target depth, stop and release the lifting handle. Then it will be locked automatically.
6. While listening to engine sound, push the machine slowly for cutting operation.

### 8.3 After Operation

1. When cutting is completed, turn the lift handle slowly clockwise to lift the machine body. (Fig.26)



2. Return the throttle lever to lower engine speed. (Fig.27)

#### CAUTION

- Do not close (OFF) the valve of water tank during running the engine.
- If the unit is to be left in standby mode for an extended period of time, stop the unit completely.

## 9. STOP

1. Close (OFF) the valve of water tank during the engine is idling speed, then check that water dose not come out from the side of blade. (Fig.28)

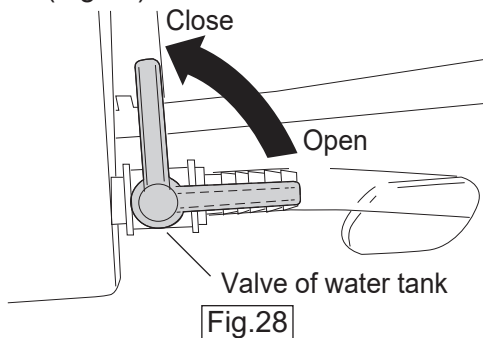

2. As soon as the water dose not come out, quickly turn the engine switch to the OFF position to stop the engine. (Fig.29)

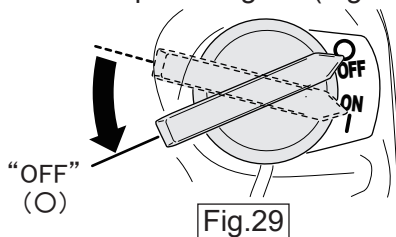

3. Close (OFF) the fuel cock. (Fig. 30)

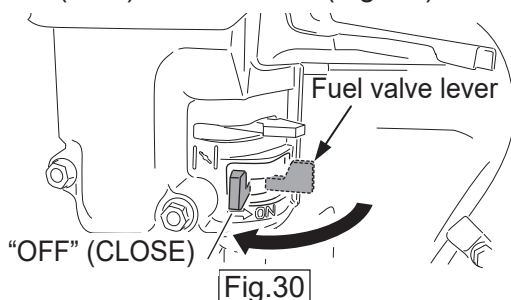

4. Stow the cutter guide. (Fig.31)

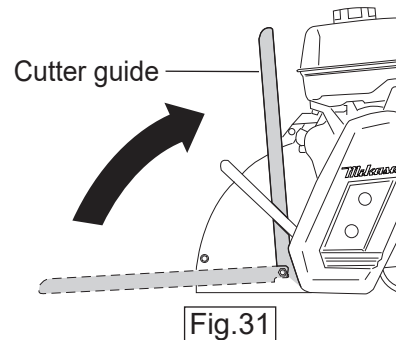

5. Drain water from the water tank. (Fig.32)

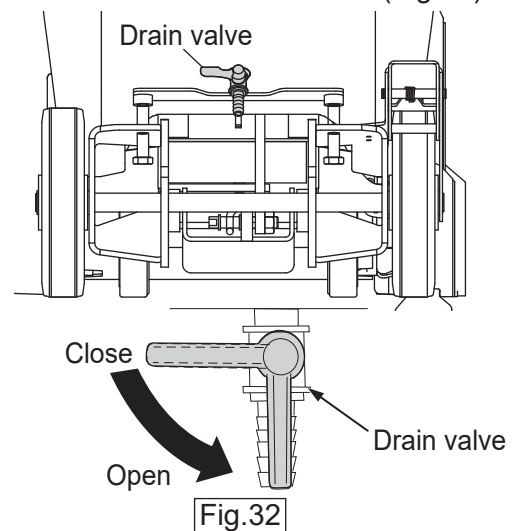

#### WARNING

- Be sure to drain all water during cold weather to avoid serious machine damage due to freeze of water.

## 10. TRANSPORT

### 10.1 Loading And Unloading

#### WARNING

- Before work of lifting, check any damage of body parts (especially, Lifting hook, etc) or looseness / omission of screws, and be sure safe.
- Stop the engine and close the fuel valve during work of lifting.
- The work of lifting uses only one-point lifting hook, and do not the work of lifting in other point (handles).
- Use enough wire rope of the strength.
- Never put any person or animal under the lifted machine.
- For safety, do not lift the machine up than required height.

1. Load and unload the machine with cranes.
2. Make sure to select a leader in loading and unloading, and work by instructions of a leader.
3. Lift the machine with the guard hook by all means, to hook fittings. Never lift the machine with handle, to hook fittings.

4. Do not sudden unload the machine. Make sure to take down the machine from the rear wheel.  
In case of suddenly unloading the machine from the front wheel, the frame (front wheel) and other machine parts may be deformed.

#### CAUTION

Do not do loading and unloading that use a gangboard, because it is very dangerous.

### 10.2 Transporting

#### WARNING

- Stop the engine at the time of the transportation, and close a fuel cock.
- Remove a blade at the time of transportation by all means.
- By all means drain fuel before transporting the machine .
- Fix the machine well not to move and fall down.

1. Cover the fuel tank when the machine is transported on rain weather.
2. When tying down the machine with ropes and etc., choose a place where the parts will not be deformed.

## 11. STORAGE

1. Clean the machine by removing residual mortar and water.
2. Drain water of the water tank, the pipe and the centrifugal pump.  
See P18 "9. STOP" on how to drain water of the centrifugal pump.
3. Supply grease to the pillow block and grease nipple of each part. Particularly, pillow block of the blade shaft should be well greased a few times by means of grease gun after work.
4. Put cover so that garbage and dust do not appear.
5. Store it in the space which no hit rays of the sun with a little moisture.

#### ● For prolonged storage

1. Drain fuel from not only fuel tank but also fuel pipe and carburetor.
2. Greasing up to each parts and check the engine oil.
3. Pull the recoil starter and stop it in the lightly compressed position.
4. Cover the air cleaner and muffler.
5. Put a wheel stopper on the rear wheel.

## 12. INSPECTION AND MAINTENANCE

### 12.1 Inspection and Maintenance Schedule

Inspection interval	Inspection parts	Inspection items	Remarks
Daily (before starting operation)	Appearance	Flaw, deformation	
	Fuel tank	Leaks, oil level, dirt	Gasoline
	Fuel system	Leaks, oil level, dirt	
	Engine oil	Leaks, oil level, dirt	Engine oil
	Air cleaner	Dust of sponge	
	Blade	Crack, damage	
	Lifting device	Function validation, oils and fats	Grease
	One-point lifting hook	Loose or missing parts, crack, breaks	
	Bolts, nuts	Loose or missing parts	
After first 20 hours	Engine oil	Replace once, after the first 20 hours	Engine oil
Every 100 hours	Engine oil	Replace	Engine oil
	Lifting screw	Crack, curve, greasing	Grease
	Lifting handle	Crack, curve, greasing	Grease
	Pillow block	Greasing	Grease
Every 200 hours	Ribbed belt	Flaw, tension	
Every 2 years	Fuel pipes	Replace	
Irregular	Air cleaner element	Replace once, after the first 50 hours	
	Pillow block	Wear, abnormal noise, creak wobble	

For details about the check and maintenance of the engine, please refer to the attached engine operation manual.

#### **CAUTION**

- The above table shows the inspection interval for standard condition.
- The inspection interval may vary depending on the condition in which the machine is used.
- For check of bolt and nut loosening and retightening, refer to the following standard tightening torque table.

Standard tightening torque table (unit: kgf·cm, 1 kgf·cm = 9.80665 N·cm)

		Bolt size							
		6 mm	8 mm	10 mm	12 mm	14 mm	16 mm	18 mm	20 mm
Material	4T (SS400)	70	150	300	500	750	1,100	1,400	2,000
	6-8T (S45C)	100	250	500	800	1,300	2,000	2,700	3,800
	11T (SCM435)	150	400	800	1,200	2,000	2,900	4,200	5,600
	In case counterpart is of aluminum.	100	300~350	650~700					

- Bolt threads used with this machine are all right-hand screw.
- Material and quality of material is marked on each bolts.

## 12.2 Grease Up

- Supply grease to the pillow block and grease fitting of each parts. (Fig.33)

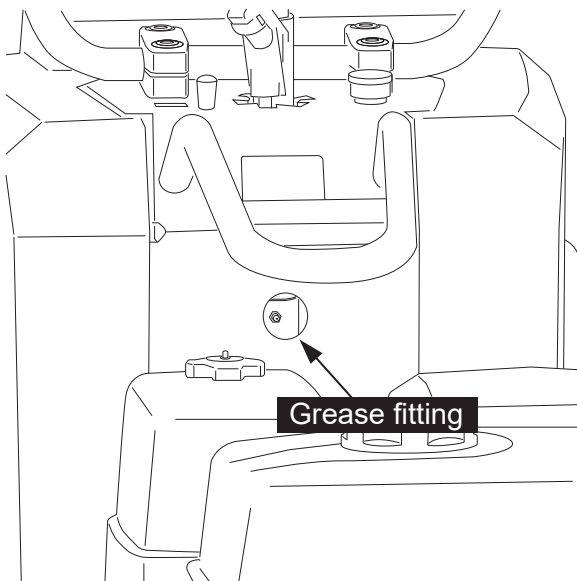
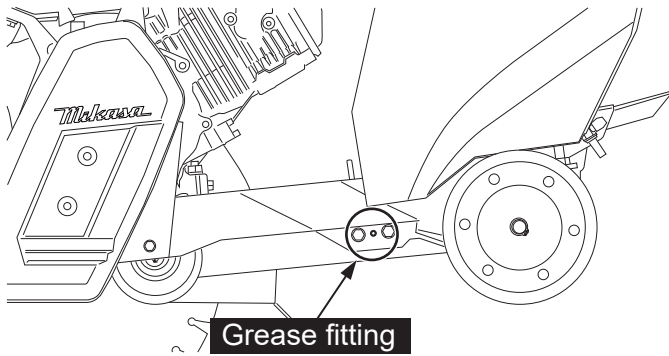
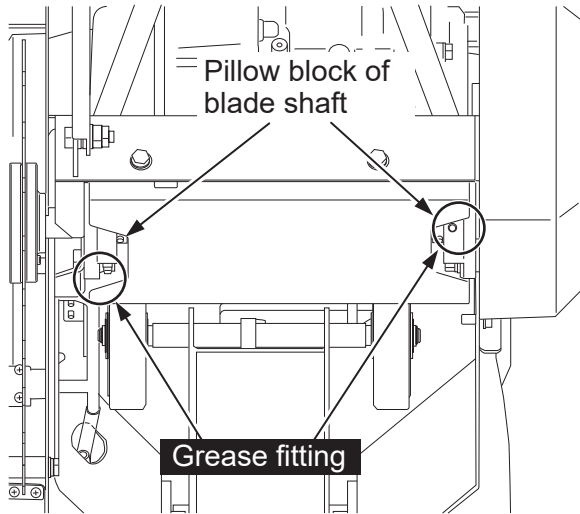

Fig.33

## 12.3 Handle Adjustment

- Check the looseness of the socket head bolts on the handle. And tighten 4 pieces of socket head bolts to fix the handle. (Fig.34)

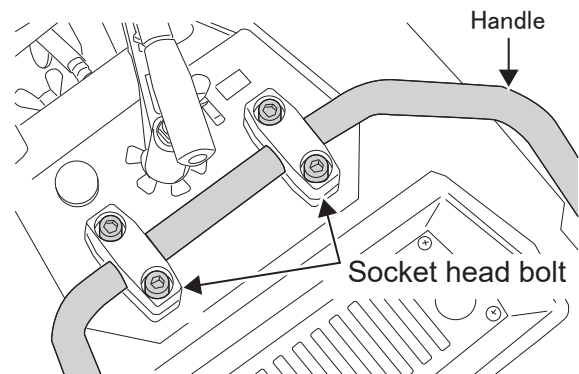
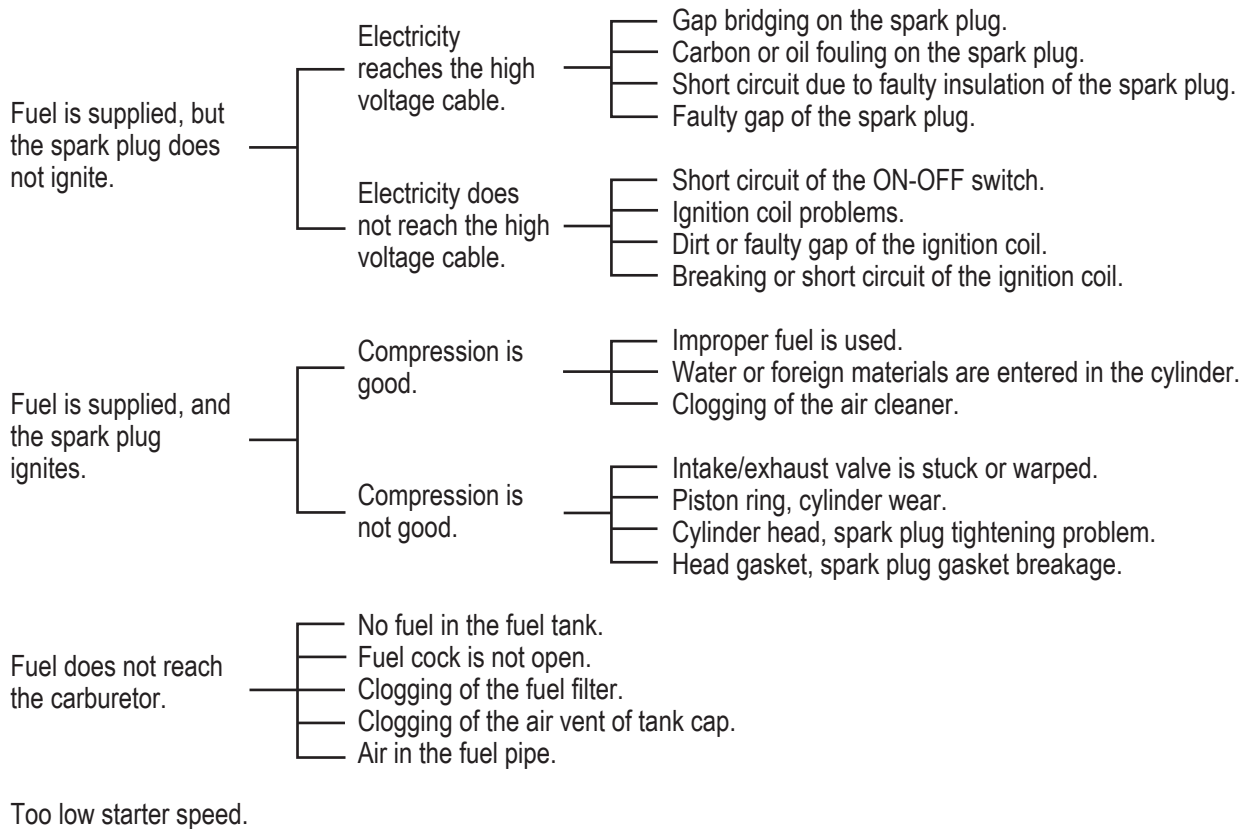

Fig.34

## 13. TROUBLESHOOTING

### 13.1 Engine

#### (1) Starting problems



#### (2) Operation problems

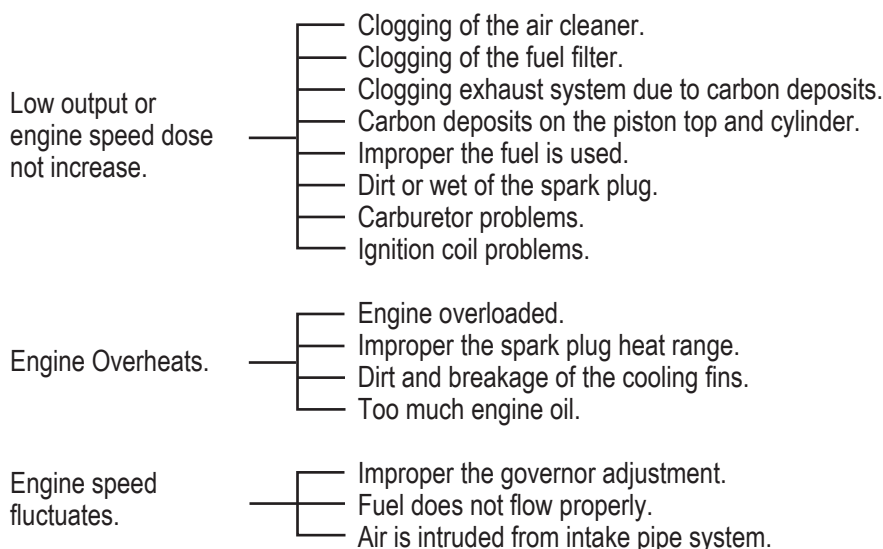

#### (3) Recoil starter problems

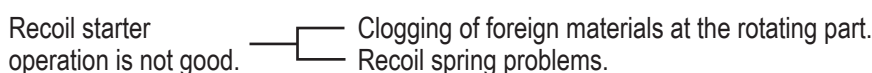



## 13.2 Machine

### Blade system

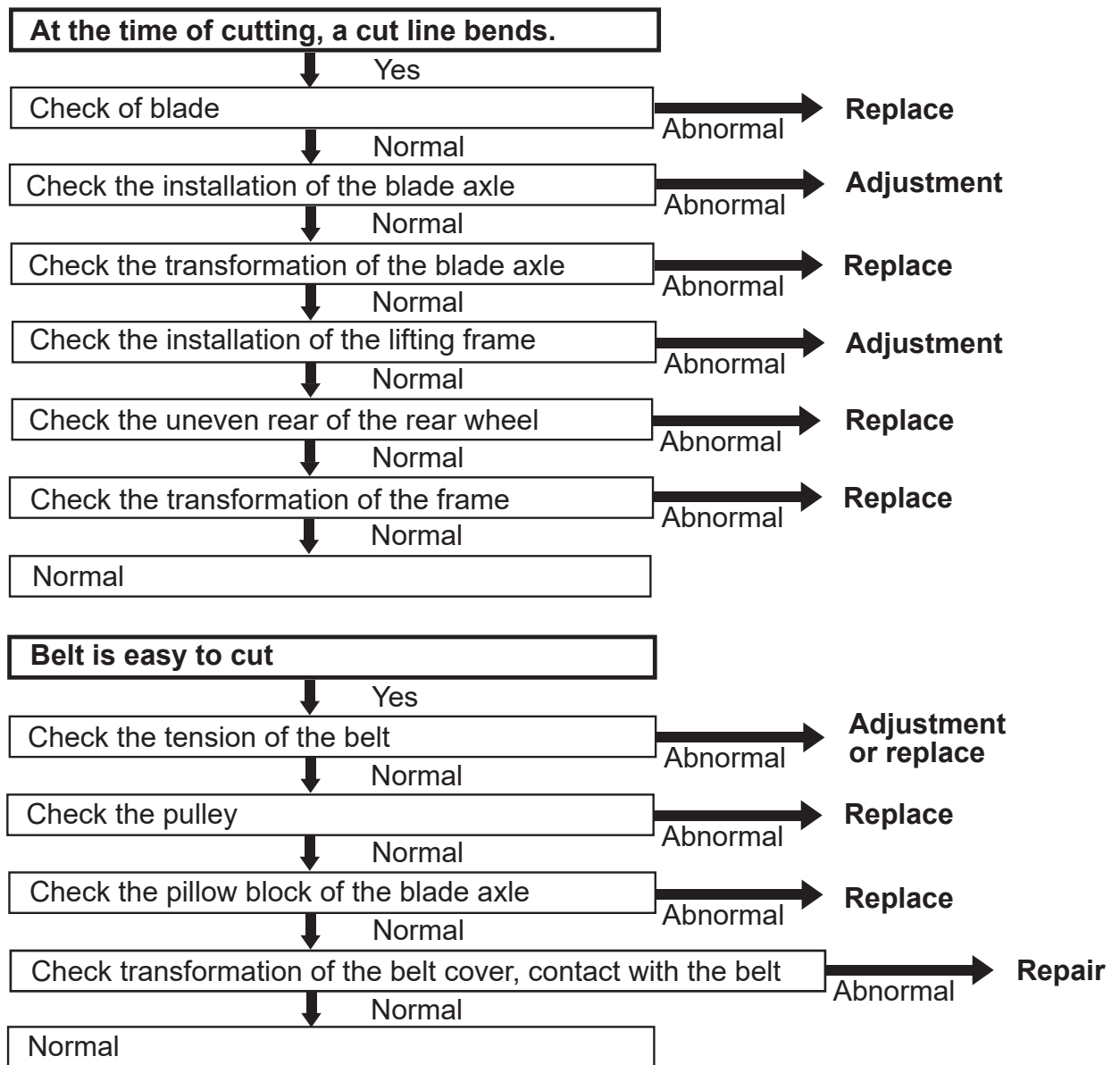

### Height Adjusting System

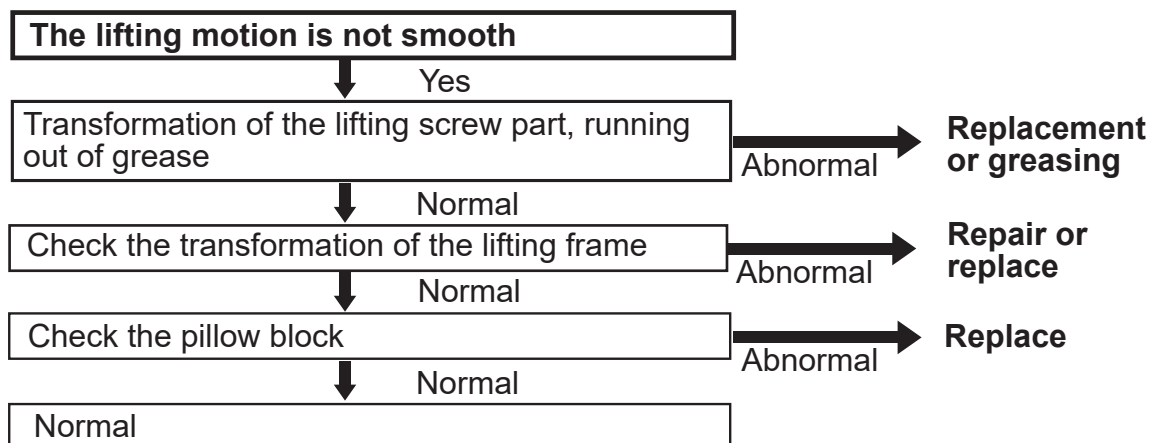

*Mikasa*

MIKASA SANGYO CO., LTD.

1-4-3, Kanda-Sarugakucho, Chiyoda-ku, Tokyo, 101-0064, Japan

COPYRIGHT 2024, MIKASA SANGYO CO., LTD.