

Mikasa

CONCRETE CUTTER

MCD-L14H

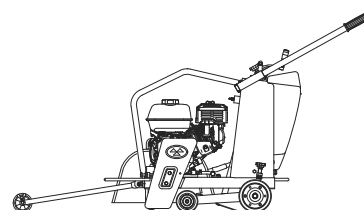

INSTRUCTION MANUAL

en



<http://www.mikosas.com>

602-01511



TABLE OF CONTENTS

1. INTRODUCTION	1
2. MACHINERY OVERVIEW	1
3. WARNING SIGNS	2
4. CAUTIONS FOR SAFETY.....	2
4.1 General Cautions	2
4.2 Refueling Precautions	3
4.3 Location And Ventilation Precautions	3
4.4 Precautions Before Starting	3
4.5 Precautions During Work	4
4.6 Lifting Precautions	4
4.7 Precautions In Transportation / Safekeeping	5
4.8 Precautions In Maintenance	5
4.9 Installed Place Of Every Decal	5
4.10 Warning Labels And Information	6
5. APPEARANCE.....	7
5.1 Dimensions	7
5.2 Parts And Component	8
6. SPECIFICATION.....	9
6.1 Main Body	9
6.2 Engine	9
7. BEFORE STARTING YOUR OPERATION.....	10
8. OPERATION	13
8.1 Starting Up	13
8.2 Working	14
9. STOPPING.....	14
10. TRANSPORTAION.....	15
10.1 Loading And Unloading	15
10.2 Precautions In Transportation	15
11. STORAGE.....	16
12. PERIODIC CHECK AND COORDINATION.....	17
13. TROUBLESHOOTING	18
13.1 Gasoline Engine	18
13.2 Machine	19

1. INTRODUCTION

- This instruction manual describes the proper methods for using Mikasa CONCRETE CUTTER, as well as simple checks and maintenances. Be sure to read this instruction manual before operation, in order to get full use of the excellent performance of this machine, as well as to improve your operation and to perform engineering work effectively.
- After reading this manual, store it in a handy location for easy reference.
- For details about the engine of this machine, see the separate instruction manual.
- For inquiries about repair parts, parts lists, service manuals, and repairs, please contact the store where you purchased the product, our sales office, or the Mikasa Parts Service Center. For parts lists, please visit our homepage at: <http://www.mikasas.com/> where you can access Mikasa WEB parts lists.

The illustrations in this manual might slightly differ in part from the machine you actually purchased due to design changes.

2. MACHINERY OVERVIEW

Application

Mikasa Concrete Cutter is used to cut the concrete or asphalt road surface by Diamond Blade that is attached on its Blade shaft. Please choose machine type by cutting depth, and then choose appropriate blade to match the spot situation, such as material age, presence or absence of reinforcement in the concrete.

Warning About Incorrect Applications And Techniques

Please use this machine to cut plain concrete, reinforced concrete and asphalt only.

Do not cut sediment, for that it flies into pieces and injures man around the machine.

This cutter can be equipped with diamond blade only. Do not attach resinoid blade on this machine. Please pour water to blade at cutting except using dry-type blade, for that conglutination of the blade or Blade chip flies into pieces.

Do not use this machine in the state that you turned more than the number of turn in accord with the blade, for that conglutination of the blade or Blade chip flies into pieces.

Do not use this machine in instability, or in a rough ground, for that conglutination of the blade or Blade chip flies into pieces.

Do not use this machine to cut a secondary product concrete.

Structure

Engine of Concrete Cutter is fixed on a main body base, and conveys power to Blade shaft with the V belt. The way of adjustment of V-belt tension is making Engine slide.

Belt cover, Handle guide, Handle for elevating the blade, and Blade cover which can be put on and off easily is attached on Engine Base. Cutting depth is adjusted by rotating Handle for elevating the blade through Blade Arm that is equipped with Front wheel The way to travel the machine is pushing the machine directly.

Power Transmission





Air-cooled petrol engine is amounted on Mikasa Concrete Cutter as power source.

V-pulley is attached on Engine shaft for driving Blade shaft, and Diamond Blade is attached on Blade shaft. The cutting depth can be adjusted to change the Front wheel position by Handle.

The way of driving the machine while cutting is pushing the handle.

3. WARNING SIGNS

The triangle shaped  marks used in this manual and on the decals stuck on the main body indicate common hazards. Be sure to read and observe the cautions described.

 Warning labels indicating hazards to humans and to equipment.	
 DANGER	Denotes an extreme hazard. It calls attention to a procedure, practice, condition or the like, which, if not correctly performed or adhered to, is likely to result in serious injury or death.
 WARNING	Denotes a hazard. It calls attention to a procedure, practice, condition or the like, which, if not correctly performed or adhered to, could result in serious injury or death.
 CAUTION	Denotes a hazard. It calls attention to a procedure, practice, condition or the like, which, if not correctly performed or adhered to, could result in injury to people and may damage or destroy the product.
CAUTION (without at )	Failure to follow the instructions may result in damage to property.

4. CAUTIONS FOR SAFETY

4.1 General Cautions

WARNING

- Do not work with this machine, when
 - you are tired or sick and not feeling well,
 - you have taken medicine or drug, or
 - you have had a drink.



CAUTION

- Read this instruction manual carefully and handle the machine as described so that you can work safely.
- For details about the engine, refer the separate instruction manual for the engine.
- Make sure you thoroughly understand the construction and operation of the machine.
- Please check each part before work, and execute the scheduled check and alignment regularly.
- To work safely, always wear protective clothing (helmet, safety glasses, safety shoes, ear plugs etc.) and appropriate work clothes.
- Please wear Hearing protector (noise protective equipment of ear muff or ear stoppers) by all means.
- Always check the machine to make sure that it is normal before starting operation.
- The decals on the machine body (operating methods, warning decals, etc.) are very important to ensure safety. Keep the machine body clean so that they can be read at all times. If any decal cannot be read, replace it with a new one.
- It is very dangerous if children come into contact with the machine. Take the utmost care how and where the machine is stored.
- Before performing any maintenance, be sure to turn the engine off.
- Mikasa does not accept any liability for accidents or problems caused as a result of not using genuine Mikasa parts or if the machine has been modified.



4.2 Refueling Precautions

⚠ DANGER

- Always refuel in a well ventilated area.
- Make sure to stop the engine and wait until the engine cools down when refueling.
- Select a flat surface area with no flammable material around for refueling. Be careful not to spill the fuel. Wipe off well if there is any spill.
- Never put fire near the machine during refueling. (Especially, be careful about smoking.)
- If you fill to the top of the fuel tank inlet, fuel might spill out from the tank, and it becomes dangerous
After refueling, tighten the tank cap well.

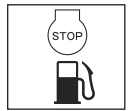

4.3 Location And Ventilation Precautions

⚠ DANGER

- Do not run the machine in an unventilated location, such as indoors or inside a tunnel. The exhaust gas from the engine contains toxic gases such as carbon monoxide and is very hazardous.
Do not operate the machine near open flames.



4.4 Precautions Before Starting

⚠ CAUTION

- Check the clamping condition of each part. Cause the big failure that does not think that a screw loosens by vibration. Tighten the screw well.
- Confirm that the diamond blade does not have anomaly such as deficit of the blade chip or the crack of the board.
- If the machine were not run more than 3 months, be sure to start at low speed in a few minutes to warm up thoroughly, for the reason to avoid engine seizure by oil film shortage.

4.5 Precautions During Work

⚠ CAUTION

- When starting and working with the machine, confirm that neighboring people and obstruction are safe.
- Always pay attention to foothold and work in easy position that allow to keep your machine in good balance.
- Be careful not to touch muffler and engine body as it becomes hot in operation or just after operation.
- Discontinue operation promptly whenever your machine goes deficient or you notice any abnormality.
- Be sure not to make the cutter with blade stand-by for work.
In the case to be without avoidance, be sure to run the engine at low speed possibly in a short time.
(In case of running the engine at high speed at the above position for long time, it might occur the engine seizure by oil film shortage.)
- Be sure to stop engine before leaving the machine. Also shutdown engine for transporting the machine, and close the fuel cock.
- Mount blade cover by all means, and use it.
- Because engine turns blade when start, be careful enough. Do not bring legs close especially.
- Be careful enough so that be not rolled up your hand or clothes in reel (inside of the belt cover).



4.5 Precautions During Work

⚠ DANGER

Precautions in inclined area

When you use machine on inclined area, various risk is accompanied. Adhere rigidly to the following precautions to a minimum, and try for further safety retention. When you cannot get safety, never use it.

- Do not leave machine in the inclined area. There is danger to cause a serious accident when machine begins to move by any chance.
- In the inclined area, grasp a handle well, and never separate a hand from machine. Machine begins to move in tare weight at the moment when you separated a hand, and there is danger to cause a serious accident.
- Because there is the danger that machine runs uncontrollably when a grip falls out from the handle, warn you enough.
- When you work in inclined area, be located in the upper part of the slope for machine by all means, and let machine face straight it below for a slope, and work.
- Stop the machine at flat space. When you stop machine in inclined area out of necessity, lower straight machine after having stopped the engine by all means, do ring stopper to the front wheel for safe retention by all means. When be collided by an automobile and be shaken in right and left, even if you put on ring stopper down the front wheel, the machine climbs ring stopper and begins to move, and be careful this risk is very likely. Even if you put on ring stopper down the back wheel, there is not effect. In addition, a parking brake of the rear wheel is not a thing to guarantee certain fixation of the machine. Use ring stopper for a front wheel on the occasion of a stop by all means.
- When put ring stopper, never go in the front side of the machine. When machine has begun to move by any chance. There is the danger of serious injury or decease, by the physical truncation with blade and the conflict of machine.
- If hand touches the blade when put ring stopper, there is danger injured seriously. Put ring stopper from the non blade cover side of the machine by all means.
- In case of stop, when water is in the water tank, the center of gravity rises and the balance worsens . Even if you put ring stopper to the front wheel at the time, it is very dangerous that the front wheel climbs over ring stopper and begins to move. In this case pull water out of the water tank by all means.
- When a road surface gets wet in inclined area, ring stopper in itself slips depending on an angle, and effect is gone. Stop on the dry road surface by all means, when you stop it in inclined area out of necessity.
- Do not work on blade installation disassembly in inclined area, because it is dangerous.
- Do not work on to cross the slope. There is danger that tumble of the machine or the damage of the blade cause a serious accident.

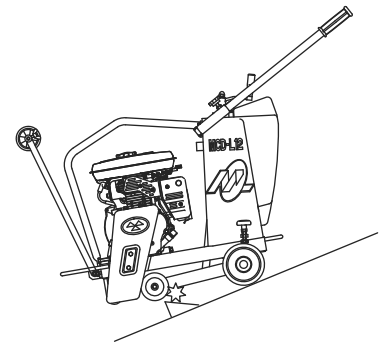

4.6 Lifting Precautions

⚠ DANGER

- Be sure to work with sling by crane license holder.
- Before work of lifting, check any damage of body parts (especially, Lifting hook, etc) or looseness / omission of screws, and be sure safe.
- Stop the engine at the time of the lifting, and close the fuel cock.
- Use enough strength of wire rope.
- The work of lifting uses only one-point lifting hook, and do not lift in other point (handles).
- Never put any person or animal under the lifted machine.
- For safety, do not lift up the machine more than required height.



4.7 Precautions In Transportation / Safekeeping

WARNING

- Stop the engine at the time of transportation.
- Carry it after engine and body got cold well.
- By all means drain fuel before transporting the machine .
- Fix the machine well not to move and fall down.

4.8 Precautions In Maintenance

CAUTION

- Appropriate maintenance is always required for safety operation and to maintain performance of the machine. Pay full attention in the condition of the machine, and maintain good condition. Especially improper maintenance of lifting-related part becomes cause of serious accident.
 - Do work after lower temperature of machine. Especially muffler becomes high temperature, and there is danger that burn itself. In addition, be careful not to burn itself enough, because engine or engine oil become hot.
 - Do the check alignment in situation that stopped engine by all means. There is badly injured danger when you are rolled up in a reel.
- After maintenance fulfillment, check the installation of safety protection parts and safety of the machine. Especially, check bolts and nuts thoroughly.
- When you do maintenance with dismantlement, refer to maintenance manual regularly, and work safely.

4.9 Installed Place Of Every Decal

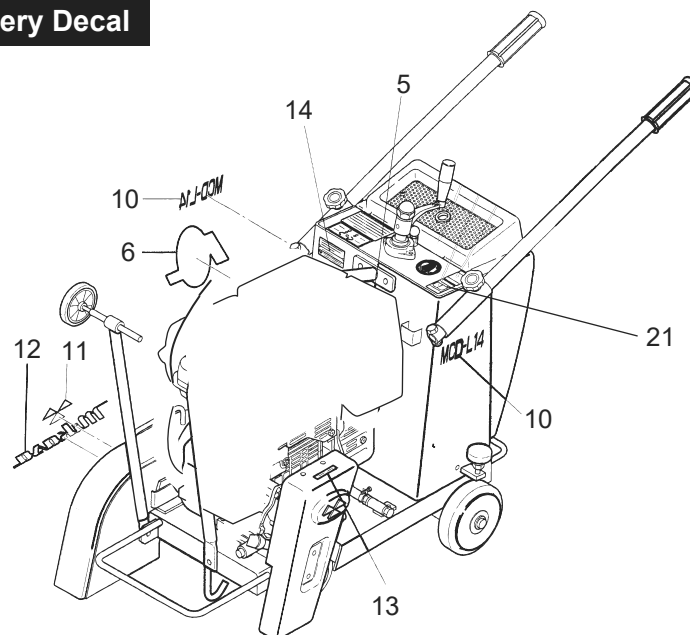

NO.	PART/NO.	PART NAME	Q'TY	REMARKS
5	9201-01200	DECAL, GREASE /NP-120	1	
6	9201-09690	DECAL, EMBLEM/CUTTER	2	
10	9201-10050	DECAL, MODEL MCD-L14	2	
11	9201-00920	DECAL, M-MARK (40X80)	1	
12	9201-01390	DECAL, MIKASA (250)	1	
13	9202-09810	DECAL, V-BELT 3V-265	1	
14	—————	PLATE, SERIAL NO.	1	
15	9202-10120	DECAL, INDICATOR/MCD12-200	1	
21	9202-10690	DECAL, CAUTION(ICON)/EXP	1	

4.10 Warning Labels And Information

Decal for new European machine directives

PART/NO. 9209-00090 DECAL, SET /MVC, MCD /EXP,EU

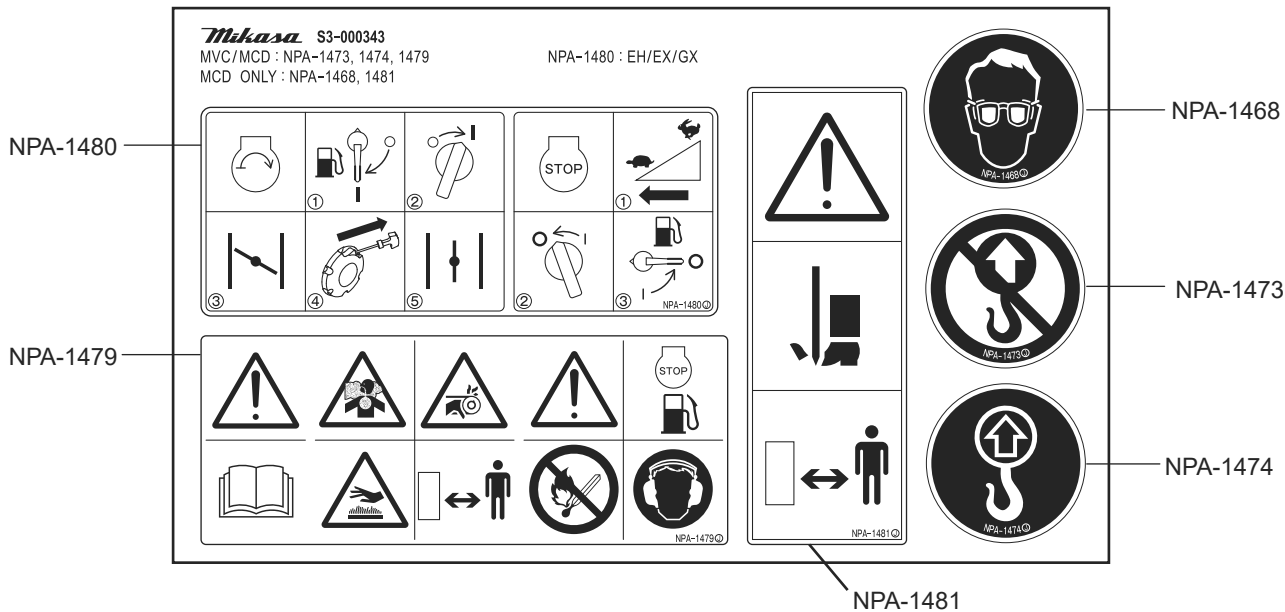

① Fire hazard

Stop the engine when refueling. Fire may occur if a flame is near the tank fuel port.



⑤ Danger of hearing damage caused by noise

Always use ear plugs while operating the machine.



② Danger: poisonous exhaust gas

Carbon monoxide poisoning may occur if the exhaust gas is inhaled. Do not operate the machine in a poorly ventilated area.



⑥ Be careful not to get burned.

Accidental burn may occur if you touch the hot parts (engine, muffler, etc.) during operation or immediately after the machine stops.



③ Do not go under the lifted machine.

Do not let people or animals go under the lifted machine.



⑦ Be careful not to be caught in rotating parts.

Make sure the engine is stopped when removing the belt cover during a belt change.



④ Lifting by the handle is prohibited.

Due to a falling risk, do not lift the machine by the handle.



⑧ Read the manual carefully.

Always read the operation manual and have good understanding of operation before your work.

5. APPEARANCE

5.1 Dimensions (mm)

MCD-L14

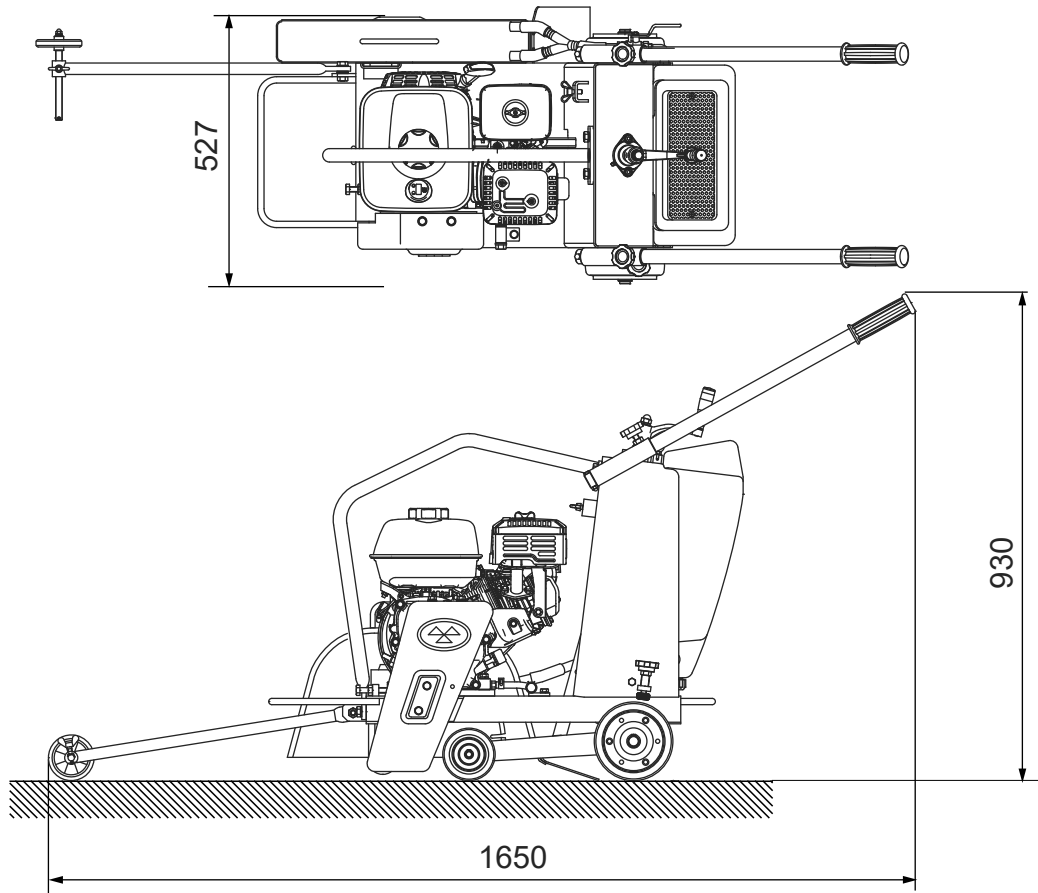

MCD-L14 (with Special handlebar)

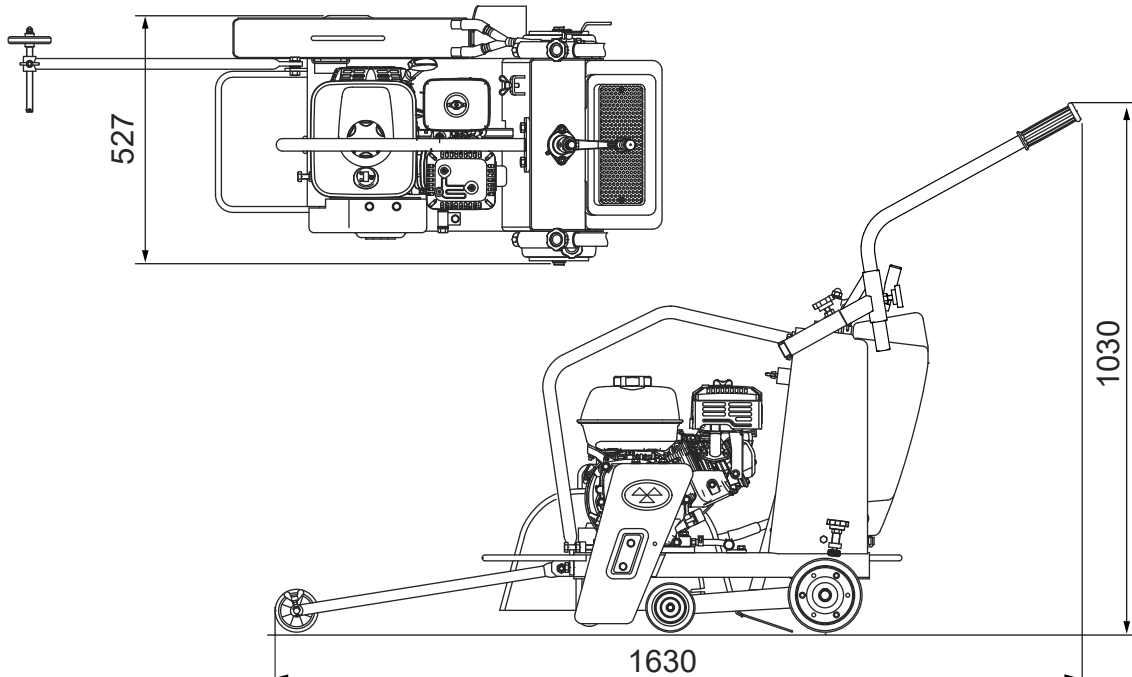

※ Specifications are subject to change without notice.

5.2 Parts And Component

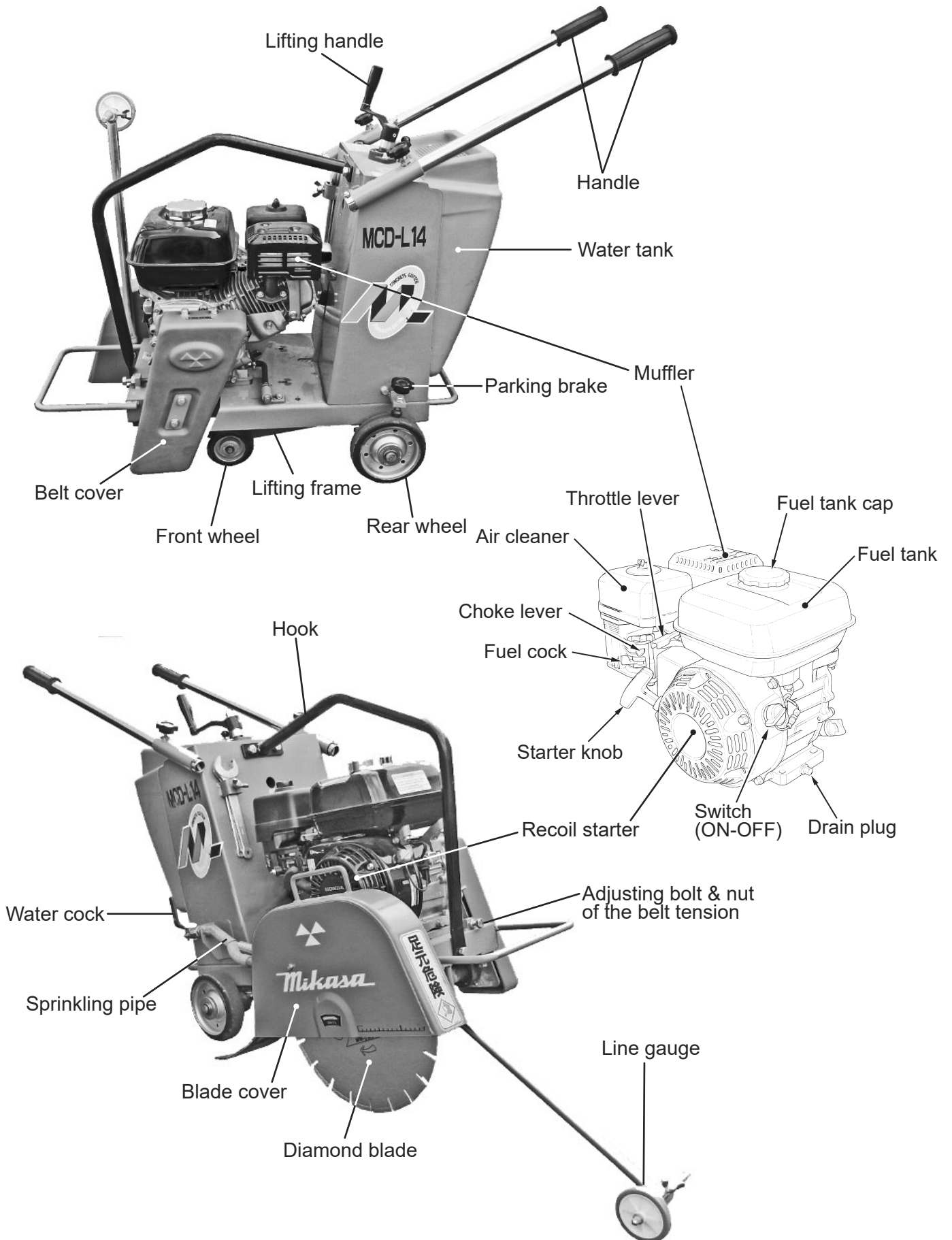

6. SPECIFICATION

6.1 Main Body

Model	MCD-L14H [with Special handlebar]
Power source (Engine model)	GX200
Dimensions	
Overall Length (on operating)	1650mm [1630mm]
Overall Width	527mm
Overall Height	930mm [1080mm]
Operating Weight	94kg[100kg]
Traveling system	Hand push type
Adjusting for cutting depth	Manual lifting screw system
Cooling System of blade	Centrifugal injection type
Water tank capacity	26L
Blade size and maximum cutting depth (Axis hole dimension of bladeφ27)	
Blade size (Outer diameter)	Maximum cutting depth
(10in.) 254mm	70mm
(12in.) 305mm	95mm
(14in.) 356mm	120mm
Limitation of Blade size	Under 14in.

※ Weight includes weigh of machine, lubricants, 50% of fuel and 50% of water in case with water tank option.

※ Specifications are subject to change without notice.

6.2 Engine

Manufacturer/ Model	HONDA, GX200
Type	Air-cooled 4-cycle petrol engine
Max. Output	4.3kW/3600min ⁻¹ (5.8PS/3600rpm)
Fuel tank capacity	3.6L

7. BEFORE STARTING YOUR OPERATION

DANGER:

Do the check alignment in situation that stopped engine by all means. There is badly injured danger when you are rolled up in a reel.

Level the machine, and check it after the machine confirmed that it does not move.

- ★ The check point before the work see "each part check schedule list" mentioned in 17 pages.

1 Engine oil (Fig.1)

With the engine positioned horizontally, check oil-with oil gauge.

Replenish through filler port as necessary. Use following oil

(10W-30 is in use when shipped).

SAE#30 (for normal temperature)

SAE#20 (for 10 or lower)

SAE#10W-30

This oil can be used throughout the year regardless of ambient temperature (up to ambient temperature -20 °C).

When it is used in normal temperature, its consumption tends to increase. Pay additional attention at the time of daily check. As for quality of oil, be sure to use SE grade or better. Degraded quality or decreased quantity may induce damage by seizure.

2 Fuel

Use lead-free automobile gasoline. For replenishment, be sure to shutdown engine and use strainer provided at filler port. Wipe off any spilled fuel clean.

3 V-belt

Check V-belt for any slack or damage. Tension is proper if the belt bends about 10mm when pressed with your finger at midway between two shafts. Retighten as necessary but when replacing, replace both of them simultaneously. Place the usable one in stand-by parts. For adjusting the tension, slide engine longitudinally.

Adjusting the belt

- A With 4 bolts removed, take off belt cover. (Fig.2)
- B Loosen 4 engine mounting bolts.

Caution: Bolts should be just loosened; not removed.

- C Rotating it clockwise increases the belt tension. (Fig.3)

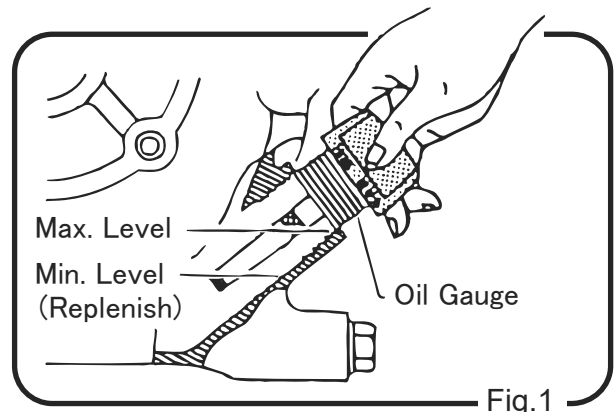

Fig.1

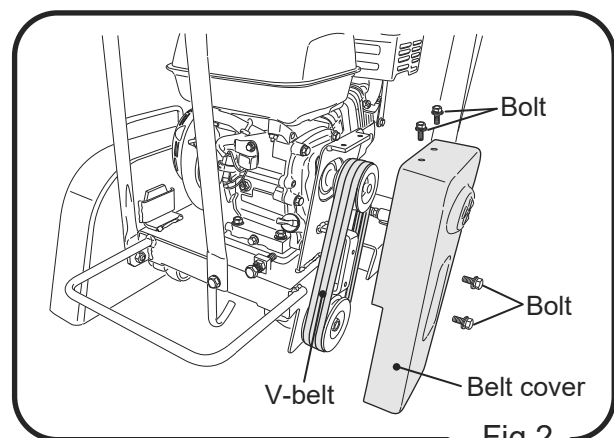

Fig.2

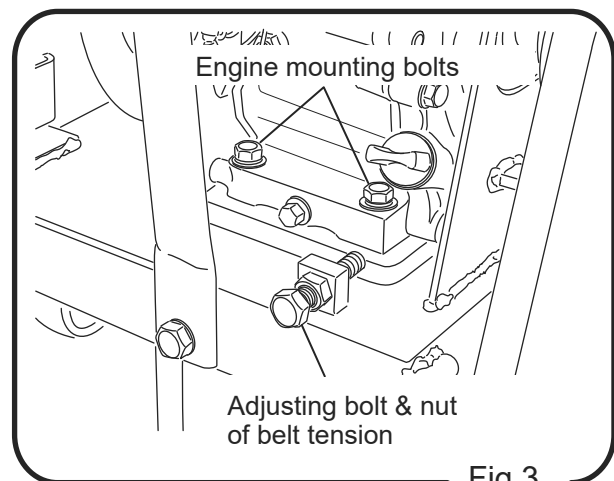

Fig.3

4 Water tank

Use water tank filled with water.
Useful life of blade depends on volume of cooling water.
Pay attention to the water level.
(Fig.4)

5 Sprinkling pipe

Open the cock to make sure that sprinkler pipe is not clogged.
(Fig.4).

6 Installing the blade:

- a. Disconnect water pipe at the nipple of water tank side. Remove the blade cover by lifting it upward.
- b. Place flange (IN), diamond blade and flange (OUT) around the blade shaft in such order, and install washer before tightening sufficiently with nut (left-hand thread). (Fig.5, 6)

Caution:

With wrench engaged at designated location of the blade shaft to lock it, rotate nut counterclockwise to tighten. (Fig.6)

- c. After installing the blade, replace blade cover to base , before replacing water hose to nipple firmly. And check the cooling water.

7 Cutting depth adjustment:

To unlock, set the knob to shallow groove.
This will enable you to exactly adjust the cutting depth by turning the lifting handle.
To lower (feed motion) the machine body, rotate lifting handle clockwise.
To raise the body, rotate the lifting handle counterclockwise.
When decided the cutting depth, set the knob at lock position for lock the position of machine. (Fig.7)

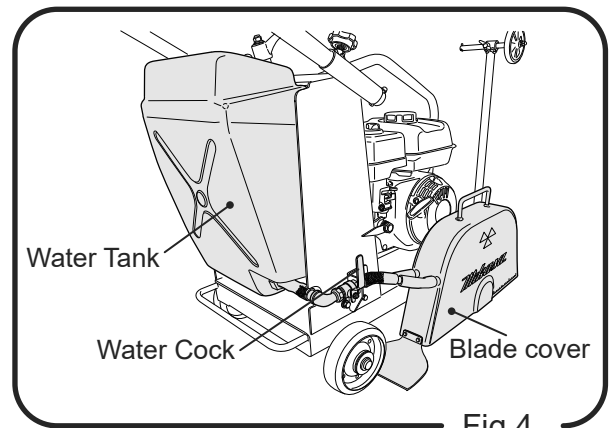

Fig.4

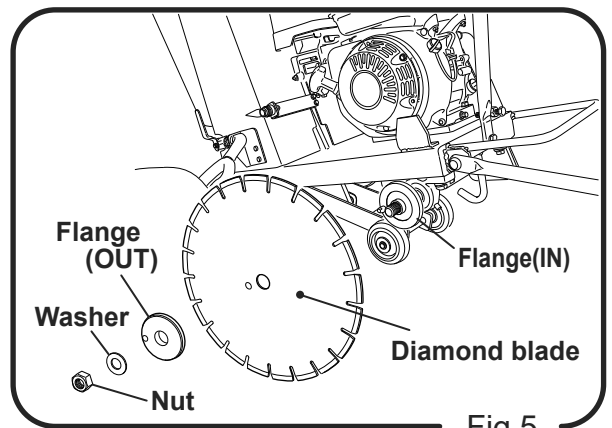

Fig.5

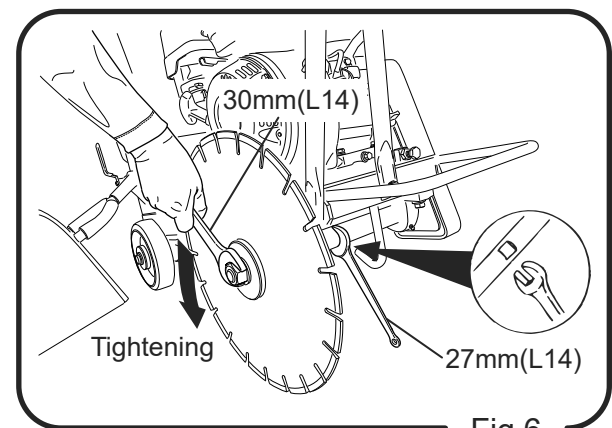

Fig.6

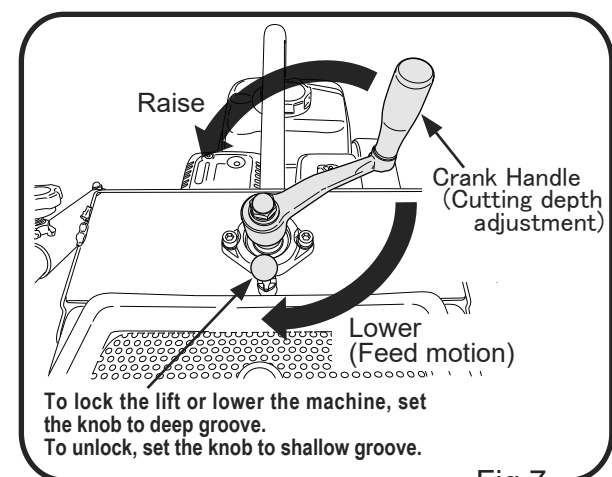

Fig.7

- 8. Move each operation lever, and check on creak or the wobble.
- 9. Check bolts and nuts for looseness or any other abnormality.

10. Parking brake

There is a parking brake to left back wheel. Turn a knob to right (a clock direction) and brake it, and turn it to the left and remove brakes. Remove brakes before the work. (Fig.8)

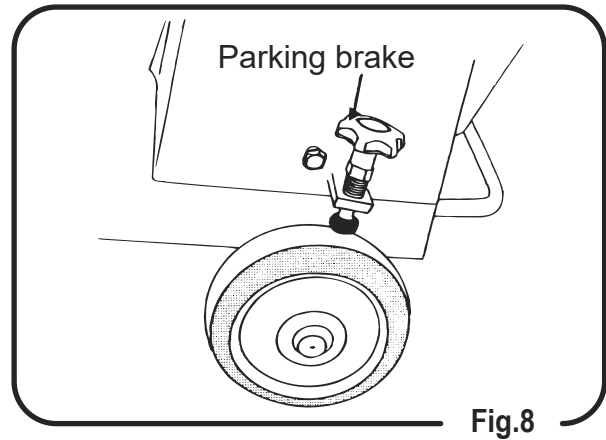

Fig.8

11. Cut depth reading method

Cut depth is distance from the reading point of Fig. 9 to blade tip. There is blade tip in circumference of blade. When you cut asphalt or concrete road with diamond blade, the line trace (trace of line) of turn happens on the side surface of blade. Search the line trace of reading point, and read distance from circumference to it with the scale of blade cover. (Fig.9)

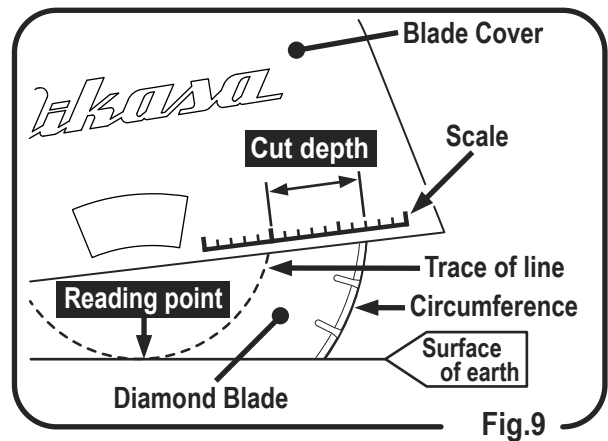

Fig.9

8. OPERATION

8.1 Starting Up

1. Move fuel cock lever with "ON" position. (Fig.10)

⚠ DANGER: The exhaust gas from the engine is carbon monoxide and is deadly. Do not run the engine in an unventilated location, such as indoors or in a tunnel.

2. When cold or somehow starting is difficult, turn choke lever to START position. This is not necessary when engine is warm. (Fig.11)

3. Move throttle control lever slightly to high speed side. (Fig.11)

4. Turn engine start switch to ON position. (Fig.12)

5. Hold recoil starter grip and pull it slightly until you feel light resistance. Pull it strongly there. Be careful not to pull it too hard because it may come off. Do not release the grip from the pulled position but return it to starter case before releasing. (Fig.13)

6. If engine has started, while listening to explosion sound, slowly return the choke lever to OPERATION position. (Fig. 11)

After started, be sure to run the engine at low speed for a few minutes.

It must be done in cold weather particularly. Check for abnormal noise or gas leak in the meantime.

⚠ DANGER: Because engine turns blade when start, be careful enough.

⚠ CAUTION: Do not allow the starter grip to snap back against the engine. Return it gently to prevent damage to the starter.

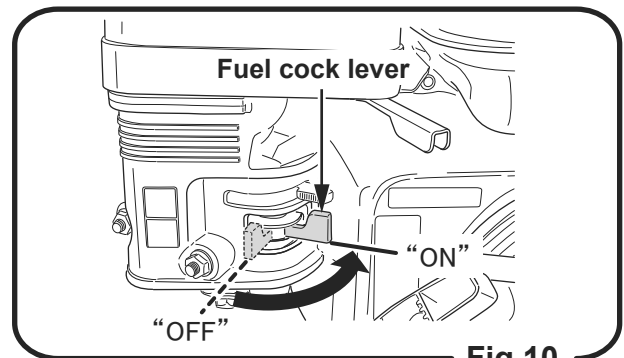

Fig.10

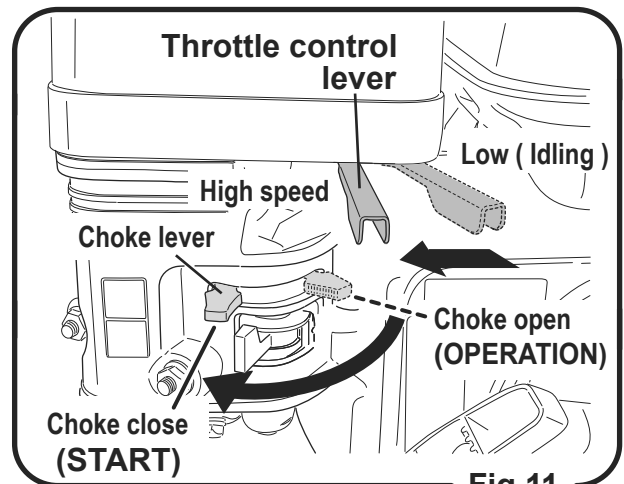

Fig.11

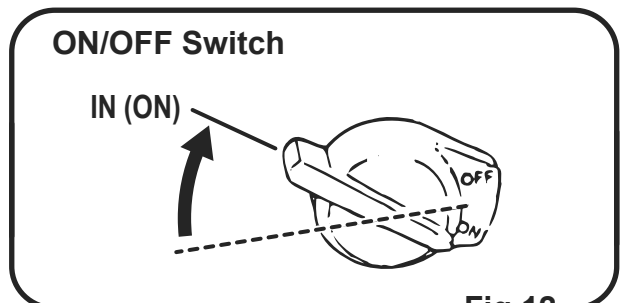

Fig.12

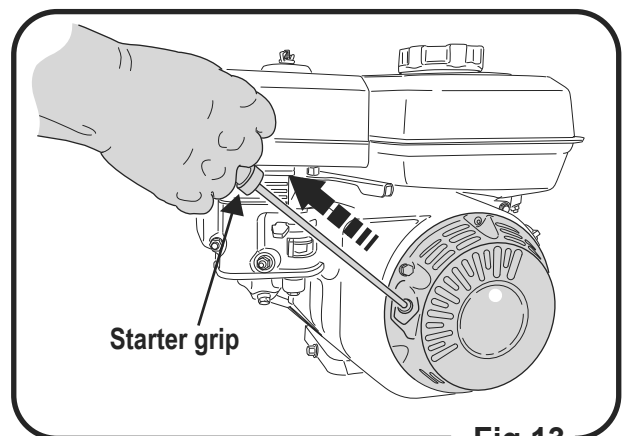

Fig.13

8.2 Working

1. Align the blade with cutting line. Aligning is easier if it is done with the machine lifted.(Fig.14)
2. With water cock opened, spray cooling water to the blade. At least 5-6 liters per minute of cooling water is required.
As the standard, if water mist is being sprayed to the extent that water does not flow, the cooling will be sufficient. Adjust the amount of water with cock. (Spray on a little heavier side when there is sufficient water.) (Fig.15)
3. Open throttle lever slowly to set engine revolution to high speed. (Fig.11)
4. To cut - in with the blade at the bottom, turn the Crank handle to clockwise, and cut down while adjustment the lowering speed so that engine speed is not reduced excessively. After cutting down, set the knob to the lock position which located beside of Crank handle to lock the machine. (Fig.16)
5. While listening to engine sound, push the machine slowly for cutting operation.

Caution: Sudden feeding or cutting may damage blade or decrease durability of engine, V-belt, etc..

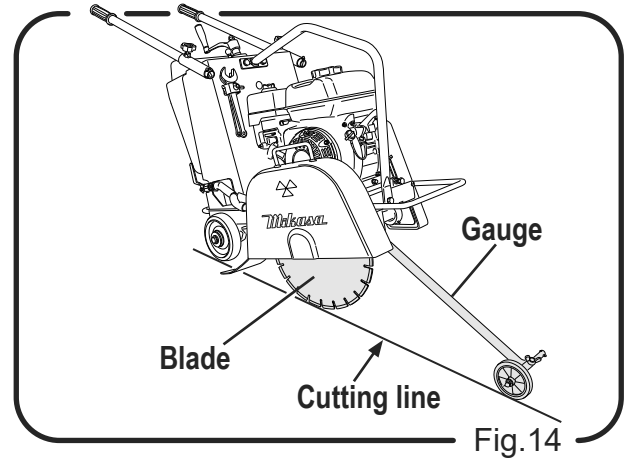

Fig.14

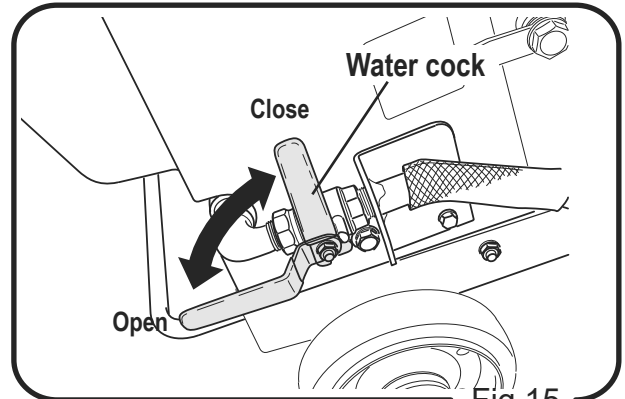

Fig.15

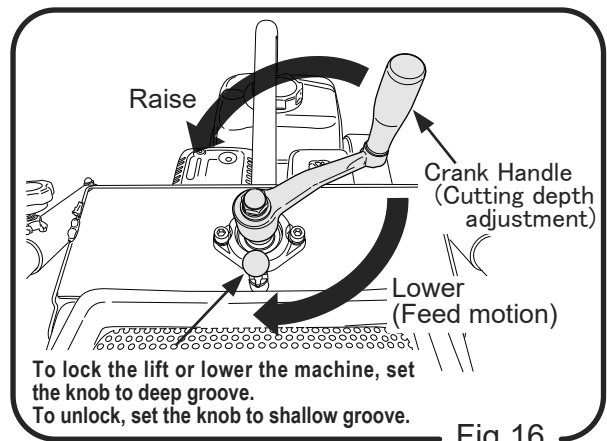

Fig.16

9. STOPPING

1. When cutting is completed, turn the lift handle slowly counterclockwise to raise the machine body.
2. Close water cock to stop cooling water spray.
3. Return throttle lever to lower engine speed. Idle the engine for a few minutes to cool down, then turn the stop switch to the STOP (O) position.

Caution: Muffler gets hot during operation. Be careful not to touch it when operating throttle lever.

4. Close(OFF) fuel cock lever.

Caution: Immediately after cutting operation, machine is hot on the whole. Be careful not incur a burn.

10. TRANSPORT

WARNING

- Before work of lifting, check any damage of body parts (especially, Lifting hook, etc) or looseness / omission of screws, and be sure safe.
- Stop the engine at the time of the lifting, and close the fuel cock.
- The work of lifting uses only one-point lifting hook, and do not the work of lifting in other point (handles).
- Use enough wire rope of the strength.
- Never put any person or animal under the lifted machine.
- For safety, do not lift the machine up than required height.

10.1 Loading And Unloading

Be sure to work the license holder of crane operation and slings.

10.1.1. Lifting work

Do loading and unloading by cranes.

10.1.2.

In loading and unloading select a leader, and work by instructions of a leader by all means.

10.1.3.

Lift the machine with the guard hook by all means, to hook fittings. **Never lift the machine with handle, to hook fittings.**

 CAUTION Do not do loading and unloading that use a gangboard, because it is very dangerous.

10.2 Precautions In Transportation

WARNING

- Stop the engine at the time of the transportation, and close a fuel cock.
- Remove a blade at the time of transportation by all means.
- By all means drain fuel before transporting the machine .
- Fix the machine well not to move and fall down.

11. STORAGE

11.1.

Clean the machine by removing residual mortar and water.

11.2.

Drain water of the water tank and the pipe.

11.3.

Supply grease to the pillow block and grease nipple of each part .

Particularly, pillow block of the blade shaft should be well greased a few times by means of grease gun after work. (Fig.17)

Be sure to grease the thread portion of lifting screw as well. (Fig.18)

11.4.

Put cover so that garbage and dust do not appear.

Store it in the space which no hit rays of the sun with a little moisture.

11.5. Proper storage:

For long term storage after work;

1. Drain fuel from fuel tank, piping and carburetor.
2. With spark plug removed, drip a few drops of engine oil into cylinder and rotate engine manually to let the oil reach everywhere inside the cylinder.
3. Pull the recoil starter and leave it where compression is felt.
4. Store the machine away, covered and in such place as it is free from direct sun, moisture and dust.
5. Keep the machine indoors without leaving it outdoors.
6. Do not overthrew the machine sideways, and do not keep it.

About engine

For daily and periodical inspection or simple maintenance services, see engine manual separated provided.

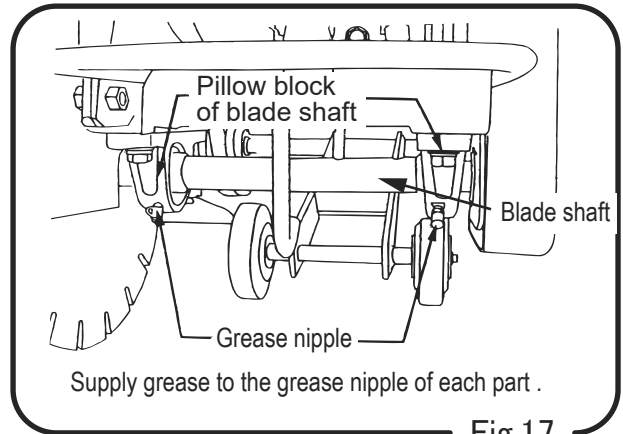

Fig.17

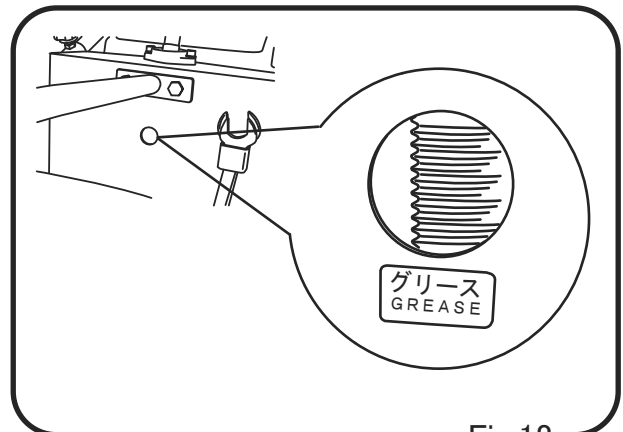

Fig.18

12. PERIODIC CHECK AND COORDINATION

1. Each part check schedule list

Check schedule	Check point	Check item	Type of oils and fats
Daily (before work)	Visual inspection	Crack, Deformation	
	Fuel tank	Leak, Quantity of Fuel, Dirt	Gasoline
	One-point lifting hook	Falling off, Breakage, Crack Looseness & falling off of bolt & nuts	
	Fuel system	Leak	
	Fuel filter	Dirt	
	Engine oil	Leak, Quantity of oil, Dirt	Engine oil
	Air cleaner	Dust of sponge	
	Blade	Crack, Damage	
	Lifting device	Function validation, Oils and fats	Grease
	Bolt, nuts	Looseness, Falling off	
20 hours	Engine oil	First time	Engine oil
Every 6 months or 100 hours.	Engine oil	Change	Engine oil
	Lifting device (Fig.18) Lifting screw	Crack, Curve, Greasing	Grease
	Pillow block (Fig.17)	Greasing	Grease
	Spark plug	Check-Clean	
	Spark arrester (optional part)	Clean	
	Fuel tank & filter	Clean	
Every year or 200 hours	V-belt	Crack, Tension	
	Air-cleaner element	Replace	
	Spark plug	Replace	
	Engine idle speed	Check-Adjust	
	Engine valve clearance	Check-Adjust	
300 hours	Engine combustion chamber	Clean	
Every 2 years	Fuel line	Change	
Irregular time	Air-cleaner element	Change of necessary	
	Pillow block	Wear, Abnormal noise, Creak Wobble	

• Check schedule (time to check) is for normal condition. It depends on use conditions.

Refer the attached engine instruction manual for the details of check & maintenance for engine.

In order to avoid deficient reassembly, watch carefully normal status of installation before removing or disassembling any part.

13. TROUBLESHOOTING

13.1 Gasoline Engine

(1) Starting problem

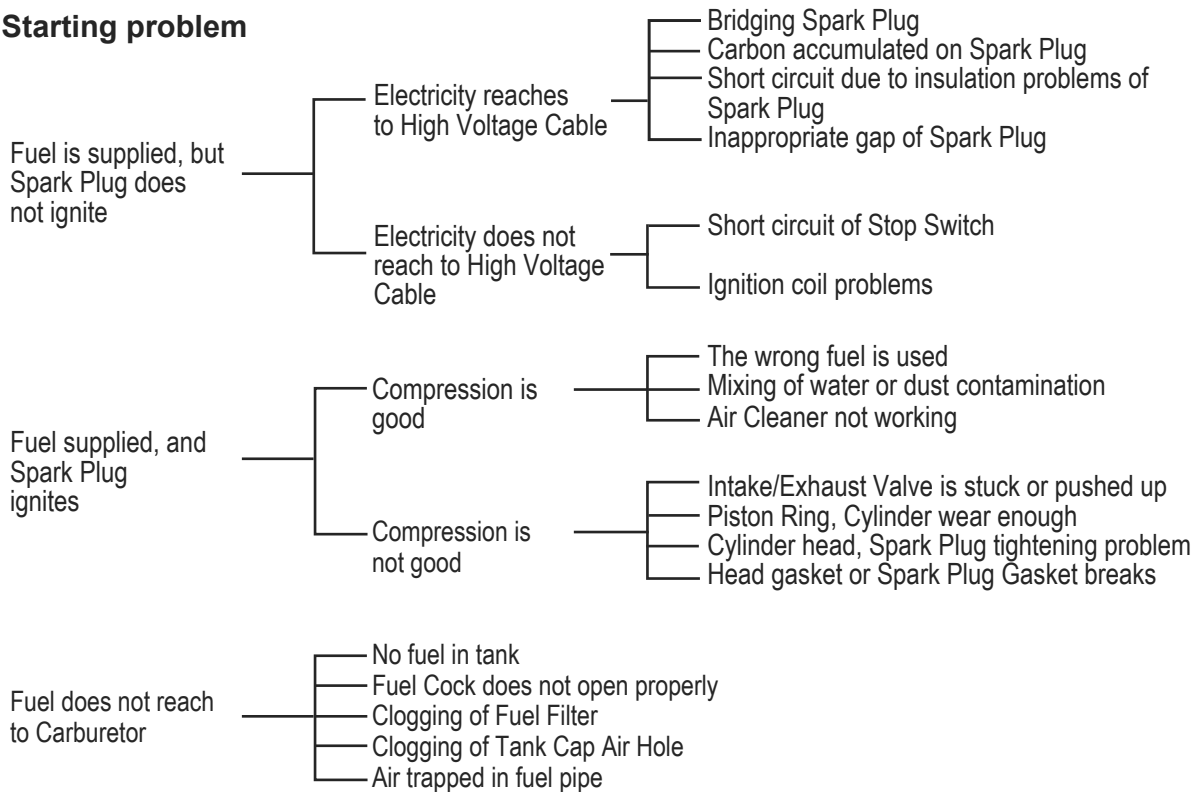

(2) Operation problem

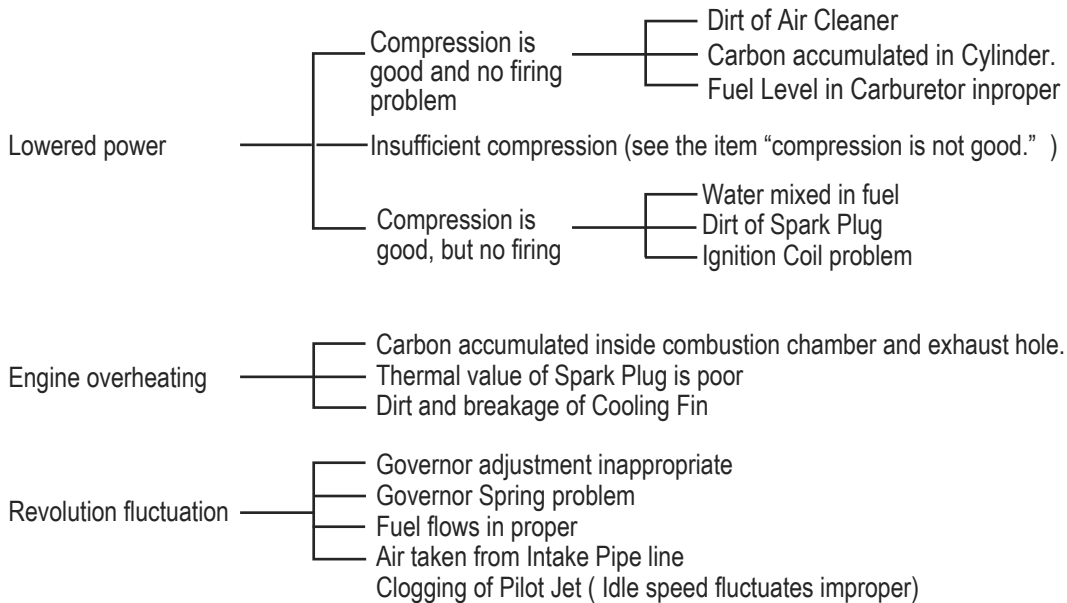

13.2 Machine

(1) Blade system

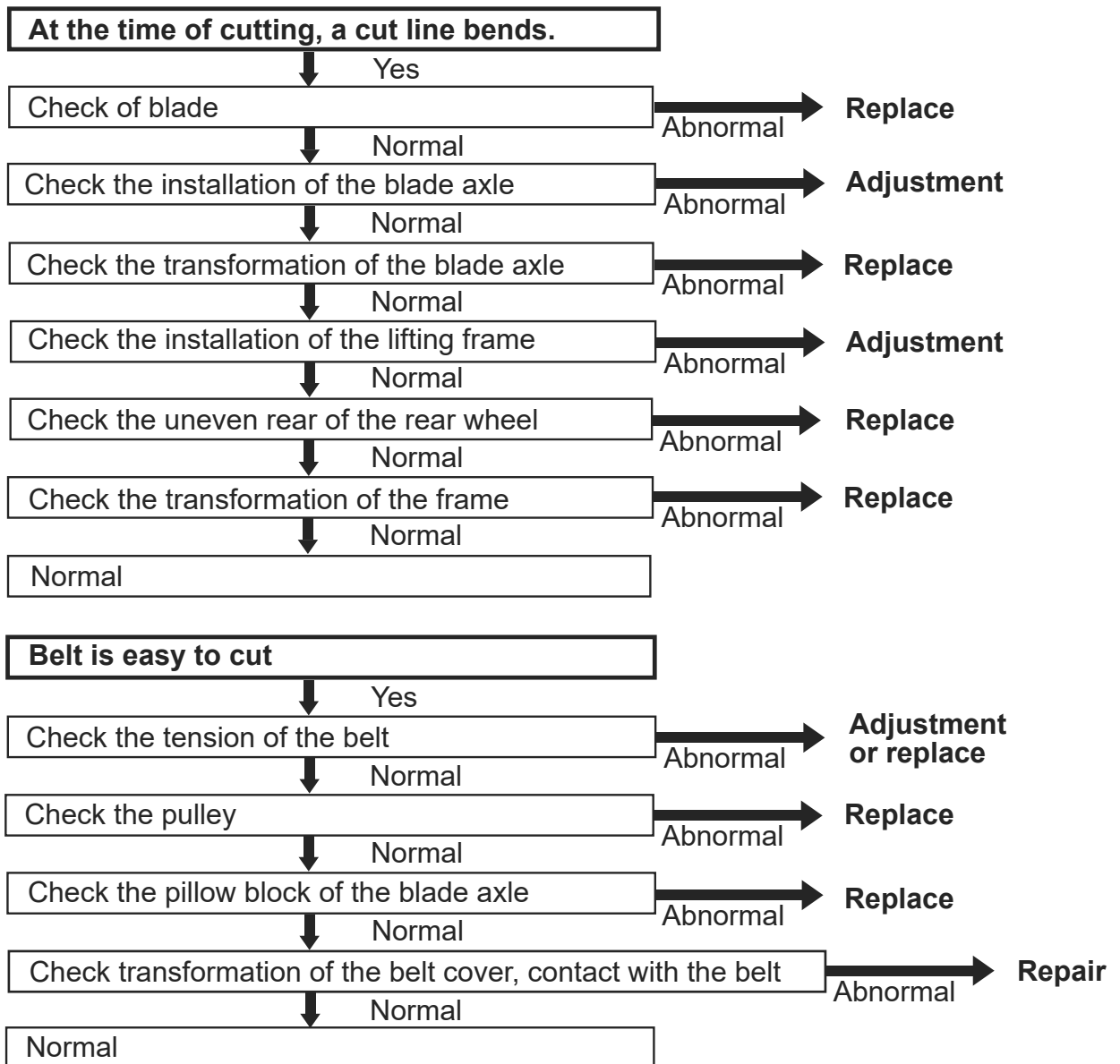

(2) Height Adjusting System

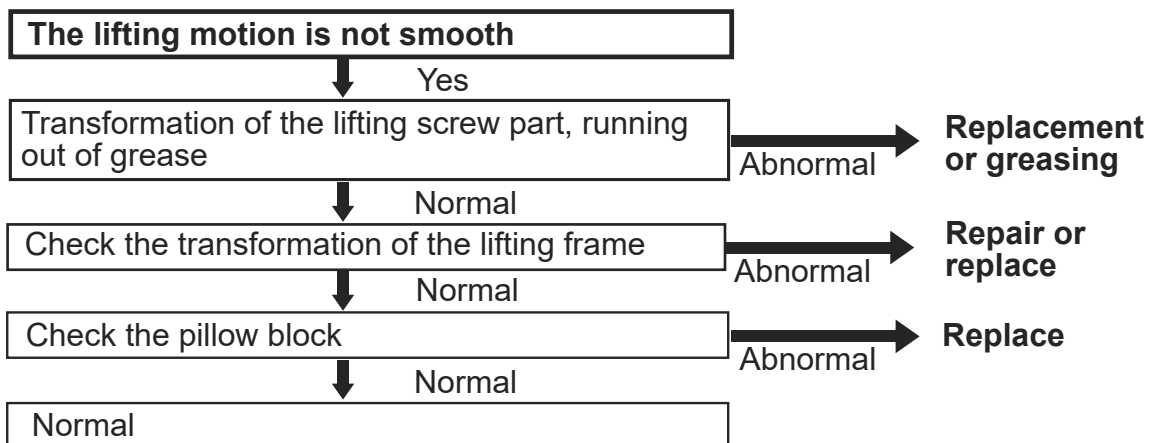

Mikasa

MIKASA SANGYO CO., LTD.

1-4-3, Kanda-Sarugakucho, Chiyoda-ku, Tokyo, 101-0064, Japan

PRINTED IN JAPAN