

Mikasa

PLATE COMPACTOR

MVC-T60

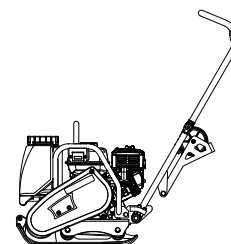

OPERATION MANUAL

en



<http://www.mikosas.com>

402-14901

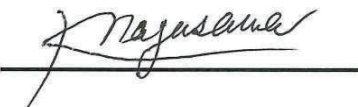

EC Declaration of Conformity

1 Manufacturer's name and address	Mikasa Sangyo Co., Ltd. 1-4-3, Kanda-Sarugakucho, Chiyoda-ku, Tokyo, 101-0064, Japan																							
2 Description of the equipment	<table style="width: 100%; border-collapse: collapse;"> <tr> <td colspan="3">Compaction machines (Vibratory Plates : Plate Compactors)</td> </tr> <tr> <td style="text-align: center;">MVC-T60</td> <td colspan="2"></td> </tr> <tr> <td style="text-align: center;">MVC-T60H VAS W</td> <td style="text-align: center;">MVC-T60VH</td> <td></td> </tr> <tr> <td></td> <td style="text-align: center;">MVC-T60VHW</td> <td></td> </tr> <tr> <td style="text-align: center;">100</td> <td colspan="2"></td> </tr> <tr> <td style="text-align: center;">105</td> <td colspan="2"></td> </tr> <tr> <td colspan="3">Air cooled , 4 stroke SI engine (Honda GX120) : 2.4 kW</td> </tr> </table>			Compaction machines (Vibratory Plates : Plate Compactors)			MVC-T60			MVC-T60H VAS W	MVC-T60VH			MVC-T60VHW		100			105			Air cooled , 4 stroke SI engine (Honda GX120) : 2.4 kW		
Compaction machines (Vibratory Plates : Plate Compactors)																								
MVC-T60																								
MVC-T60H VAS W				MVC-T60VH																				
				MVC-T60VHW																				
100																								
105																								
Air cooled , 4 stroke SI engine (Honda GX120) : 2.4 kW																								
2.1 Product																								
2.2 Type																								
2.3 Version(s)																								
2.4 Measured sound power level dB(A)																								
2.5 Guaranteed sound power level dB(A)																								
2.6 Motor type : Net power																								
3 Conformity assessment procedure	Annex VIII of 2000/14/EC as last amended by 2005/88/EC																							
4 Notified Body's name and address	TÜV Rheinland LGA Products GmbH Tillystraße 2, 90431, Nürnberg, Germany Notified Body number: NB 0197																							
5 Comply with relevant provisions and requirements of the following directives and standards	2000/14/EC , 2006/42/EC , 2014/30/EU EN 500-1:2006 +A1:2009 , EN 500-4:2011																							
6 Signature	 <hr style="width: 200px; margin: 0 auto;"/>		Sep. 2023																					
	Kenichi Nagasawa : Director, General Manager R&D Division																							
7 Technical documentation keeper	Engineer , R&D Division , Mikasa Sangyo Co., Ltd. 15-1,Shimoosaki,Shiraoka-city,Saitama,349-0203,Japan																							
Reference data	MVC-T60H VAS W	MVC-T60VH																						
Hand-arm vibration level ※ Ahv m/s ²	2.2	2.7																						

※ Directive 2002/44/EC compliant. Test course (crushed gravel) is in comply with EN 500-4

TABLE of CONTENTS

1. INTRODUCTION	1
2. MACHINE OVERVIEW	1
3. WARNING SIGNS	2
4. CAUTIONS FOR SAFETY	2-6
5. SPECIFICATIONS	7
6. APPEARANCE	8-9
7. INSPECTION BEFORE OPERATION	10-12
8. OPERATION	13
9. STOPPING THE MACHINE	14
10. TRANSPORTATION	15
11. STORAGE	15
12. REGULAR CHECK AND ADJUSTMENT	16-17
13. TROUBLE SHOOTING	18-19

1. INTRODUCTION

- This operation manual describes the proper operation, basic inspection and maintenance procedures of the plate compactor. Please read this operation manual before use in order to maximize the excellent performance of this machine and make your work more efficient and effective.
- After reading the manual, please keep it in a handy location for easy reference.
- For the handling the engine, please refer to the separate engine operation manual.
- For inquiries about repair parts, parts lists, service manuals, and repairs, please contact the store where you purchased the product, our sales office, or the Mikasa Parts Service Center. For parts lists, please visit our homepage (<https://www.mikasas.com>) where you can access Mikasa WEB parts lists.

The illustrations in this manual might slightly differ in part from the machine you actually purchased due to design changes.

2. MACHINE OVERVIEW

Application

Plate compactor is the machine that compacts the ground and it intends to make the surface smooth, by transmitting vibration through vibrating plate, which power generated from single rotor in vibrator case.

This machine is suitable for making the ground surface smooth, such as leveling the soil and sand, finishing the asphalt paving.

Warning About Incorrect Applications And Techniques

This machine is hard to move forward on a soil with much water (especially clay soil). It is not suitable for such application. This machine is difficult to level a ground include big stones due to insufficient compacting force. Plate compactor is mainly applied for compacting surface smooth and it is not effective for jobs that requires heavy compaction. In case of compacting ground deeply into lower layer, it is recommended to use Tamping Rammer, Reversible Compactor or Vibration Roller of which compacting force is rather effective. Please use this compactor for compacting surface on soil, sediment, sand and asphalt. It is not recommended for use this machine for the other applications.

Structure

The upper part is made up of Power source, Handle, Belt Cover, Water Tank for sprinkling and Guard Hook which are fixed by Engine Base. The Engine base is fixed on Vibrating Plate by Shock Absorbing Rubber. The lower part is made up of Vibrating Plate and Vibrator Unit that has an Eccentric rotary shaft built in. The power source is transmitted from the centrifugal clutch on engine output shaft to the Eccentric rotary shaft through V-belt.





Power Transmission

The power unit is used the 4-cycle single cylinder air cooled gasoline engine. The engine output shaft is equipped with the centrifugal clutch pulley. The centrifugal clutch pulley is engaged when increasing the engine speed. Then, the engine speed is transferred to the vibrator through the V belt. The engine speed is converted to the specified speed to rotate the eccentric shaft of the vibrator by the ratio of the clutch pulley to the vibrator pulley. The vibrator is generated the vibration by rotating the eccentric shaft.

The vibration generated by the vibrator is transferred to the vibrating plate. The vibration of vibrating plate carries the machine forward, and the vibration with the weight of the machine is compacted the ground.

3. WARNING SIGNS

The triangle shaped  marks used in this manual and on the decals stuck on the main body indicate common hazards. Be sure to read and observe the cautions described.

 Warning labels indicating hazards to humans and to equipment.	
 DANGER	Denotes an extreme hazard. It calls attention to a procedure, practice, condition or the like, which, if not correctly performed or adhered to, is likely to result in serious injury or death.
 WARNING	Denotes a hazard. It calls attention to a procedure, practice, condition or the like, which, if not correctly performed or adhered to, could result in serious injury or death.
 CAUTION	Denotes a hazard. It calls attention to a procedure, practice, condition or the like, which, if not correctly performed or adhered to, could result in injury to people and may damage or destroy the product.
CAUTION (without at )	Failure to follow the instructions may result in damage to property.

4. CAUTIONS FOR SAFETY

4.1 General Cautions

WARNING

- Do not work with this machine, when
 - you are tired or sick and not feeling well.
 - you have taken medicine or drug.
 - you have had a drink.



CAUTION

- Please read the operation manual well and work safely by using the machine properly.
- For handling of the engine, please refer to the separate engine operation manual.
- Please have a good understanding of the structure of this machine.
- Make sure to do work start inspection, regular self inspection and specified self inspection.
- To make your work safe, please use protective equipment (use specified helmet, protective shoes, etc.) and wear appropriate work clothes.
- Always use noise protection equipment such as ear muffs or ear plugs.
- Always check the machine to make sure it is in normal condition before operating the machine.
- The nameplates attached to the machine (nameplates showing operation method, warning, etc.) are very important for your safety. Clean the machine so that the nameplates can be read easily. If it is difficult to read the nameplate, please replace the old one with a new one.
- It is dangerous for young children to come near the machine. Please pay careful attention to the method of storing and the storage location for this machine. Especially the engine start key has to be taken out every time you finish your work, and keep it in a designated location.
- To do maintenance work, stop the engine and remove the battery wiring.
- We are not responsible for accidents that have occurred after the machine was refurbished without approval from the manufacturer.



4.2 Refueling Precautions

DANGER

- Always refuel in a well ventilated area.
- Make sure to stop the engine and wait until the engine cools down when refueling.
- Select a flat surface area with no flammable material around for refueling. Be careful not to spill the fuel. Wipe off well if there is any spill.
- Never put fire near the machine during refueling. (Especially, be careful about smoking.)
- If you fill to the top of the fuel tank inlet, fuel might spill out from the tank, and it becomes dangerous
- After refueling, tighten the tank cap well.

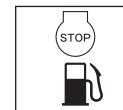

4.3 Location And Ventilation Precautions

DANGER

- Do not run the machine in an unventilated location, such as indoors or inside a tunnel. The exhaust gas from the engine contains toxic gases such as carbon monoxide and is very hazardous.
- Do not operate the machine near open flames.



4.4 Precautions Before Starting

CAUTION

- Check each part to see if it is tightened properly. Vibration causes loosening of bolts, which results in unexpected serious malfunctions of the machine. Tighten the bolts securely.

4.5 Precautions During Work

CAUTION

- Before starting the machine, make sure it is safe to start by checking your surroundings for people and objects.
- Always pay attention to your footing. Work in an area where you can maintain a good balance of the machine and a safe comfortable posture.
- The engine and muffler become very hot. Do not touch immediately after the machine stops because they are still very hot.
- If you notice deterioration of machine operation during your work, stop your work immediately.
- When moving away from the machine, stop the engine and make sure that the machine is completely tied down. Stop the engine also when moving the machine to other location.
- Keep fingers, hands, hair and clothing away from all moving parts (such as inside the belt cover) to prevent injury.
- Work on sloping ground is very dangerous. Pay full attention for safe operation of the machine during working on sloping ground.
- Keep both hands on the handle during working on sloping ground to prevent accident.
- Never leave the machine unattended on sloping ground. Serious accident might occur if the machine left unattended begins to move.
- In case of the machine with electric starter, do not operate without the battery. If you operate without the battery, electrical system failure might occur.



4.6 Lifting Precautions

DANGER

- Before lifting, check the machine parts (especially the hook and shock absorbers) for any damage and loosened or missing bolts.
- Stop the engine and close the fuel cock during lifting.
- Use a sufficiently strong wire rope.
- For lifting, use only the lifting hook, and do not lift at any other part.
- When the machine is lifted, never let people or animals come underneath.
- For safety reasons, do not lift to a height that is higher than necessary.



4.7 Transportation And Storage Precautions

WARNING

- Stop the engine and close the fuel cock during transportation.
- Transport after the engine and the machine are cooled down.
- Always drain the fuel before transporting.
- Tie down the machine securely to prevent the machine from moving or falling during transportation.



4.8 Maintenance Precautions

WARNING

- Appropriate maintenance is required to ensure safe and efficient operation of the machine. Always pay attention to the machine's condition and keep it in good condition. Pay special attention to the parts used for lifting, if they are not maintained properly, it might result in a serious accident.
- Start maintenance work after the machine has cooled down completely. The muffler, in particular, becomes very hot, and there is a danger of burn. The engine, engine oil and vibrator also become very hot. Be careful not to get burned.



CAUTION

- Always stop the engine before inspection and adjustment. If you are caught in a rotating part, serious injury might occur.
- After maintenance work, check the security parts to see if they are securely installed. Special attention should be paid when checking bolts and nuts.
- If disassembly is involved in maintenance, refer to the maintenance instruction manual to make your work safe.



About The Battery

DANGER

- If the battery fixing bolts have been removed, put them back and tighten securely to fix the battery.
If used with the battery not fixed properly, contact with the battery terminal might occur, leading to electric shock and electric leak, or breakage of the battery might occur by the impact and vibration from outside, resulting in battery fluid leakage.
- The gas from the battery might cause an explosion. Do not generate sparks or bring flames near the battery.
- Never put the positive terminal and negative terminal come into contact. Sparks will be generated, and ignition might occur.

WARNING

- Be careful when handling the battery fluid because it is very toxic. If the battery fluid gets on your skin, eye, or clothes, rinse it off with plenty of water and consult with a doctor.

4.9 Decal Position

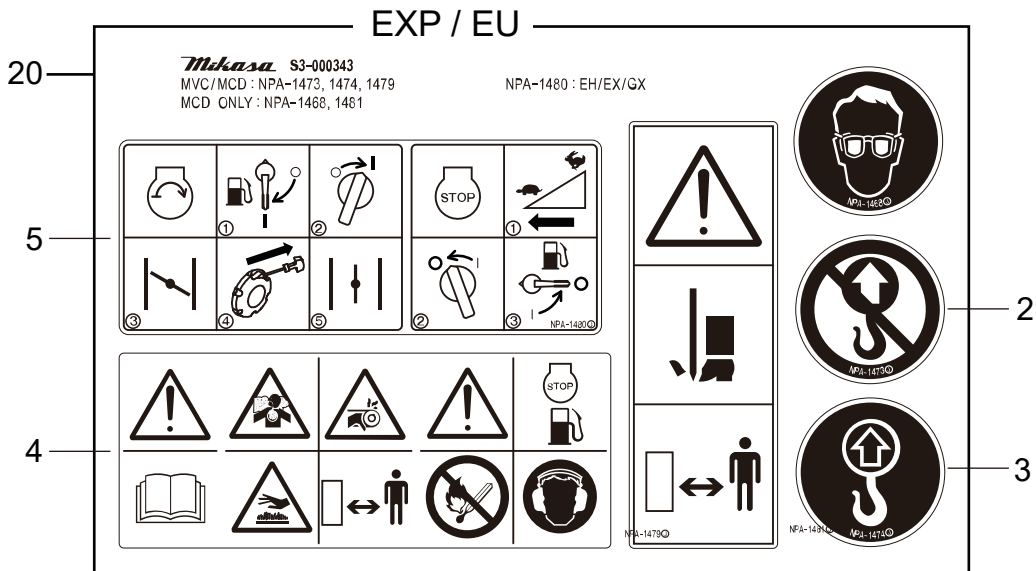
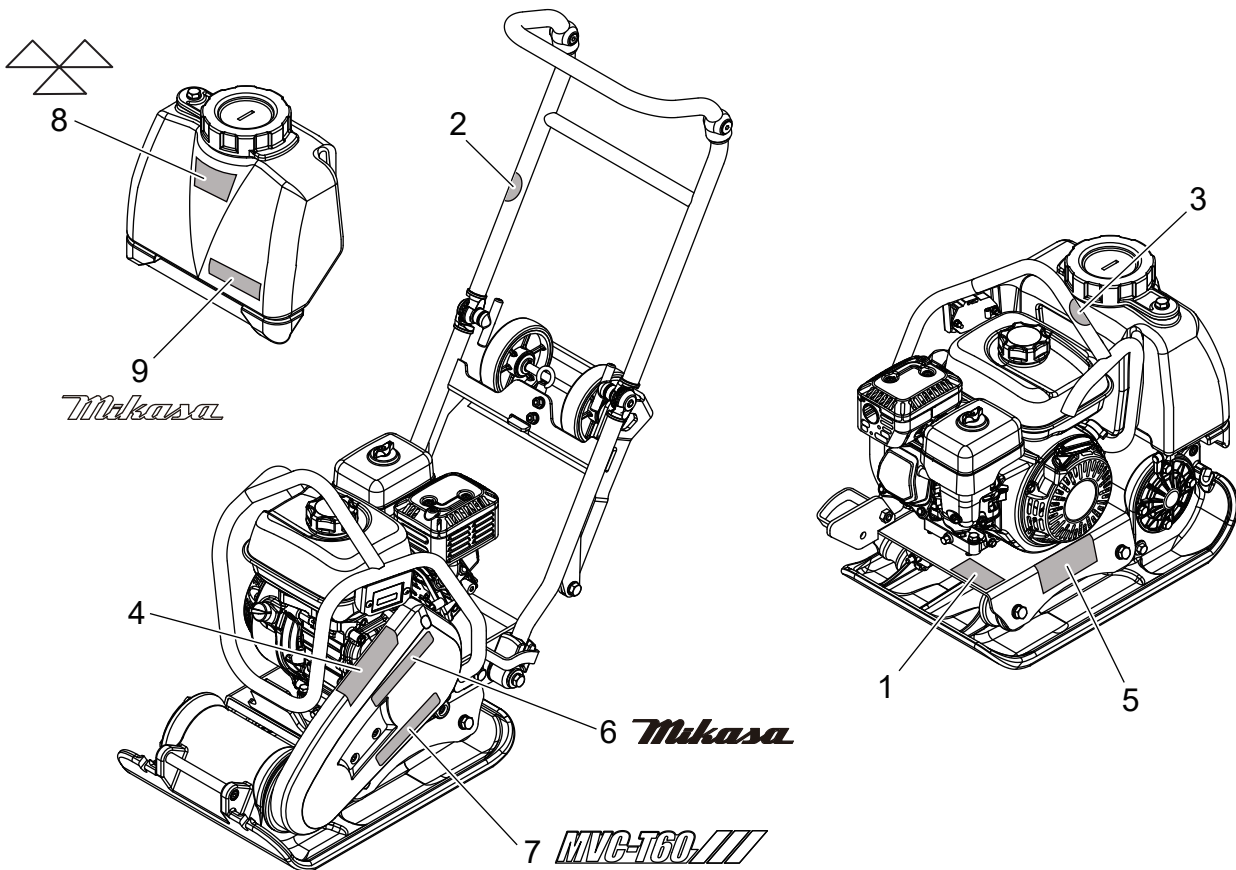

No.	PART No.	PART NAME	Q'TY	REMARK
1	-	SERIAL NO.PLATE / MVC-T60H	1	
6	9201-14000	DECAL,MIKASA(125)BLACK	1	
7	9202-25630	DECAL,MODEL(GR)/MVC-T60H	1	GREEN
	9202-25640	DECAL,MODEL(OR)/MVC-T60H	1	ORANGE
8	9202-10960	DECAL,MIKASA(125)WHITE	1	For Water Tank
9	9202-25720	DECAL,MIKASA MARK,WHITE	1	For Water Tank
20	9209-00090	DECAL,SET/MVC-MCD/EXP,EU	1	INCL. 2-5

4.10 Descriptions Of Symbols Used On Warning Decals

P/N 9209-00090 DECAL, SET /MVC, MCD /EXP,EU includes NPA-1473, 1474, 1479 and 1480.

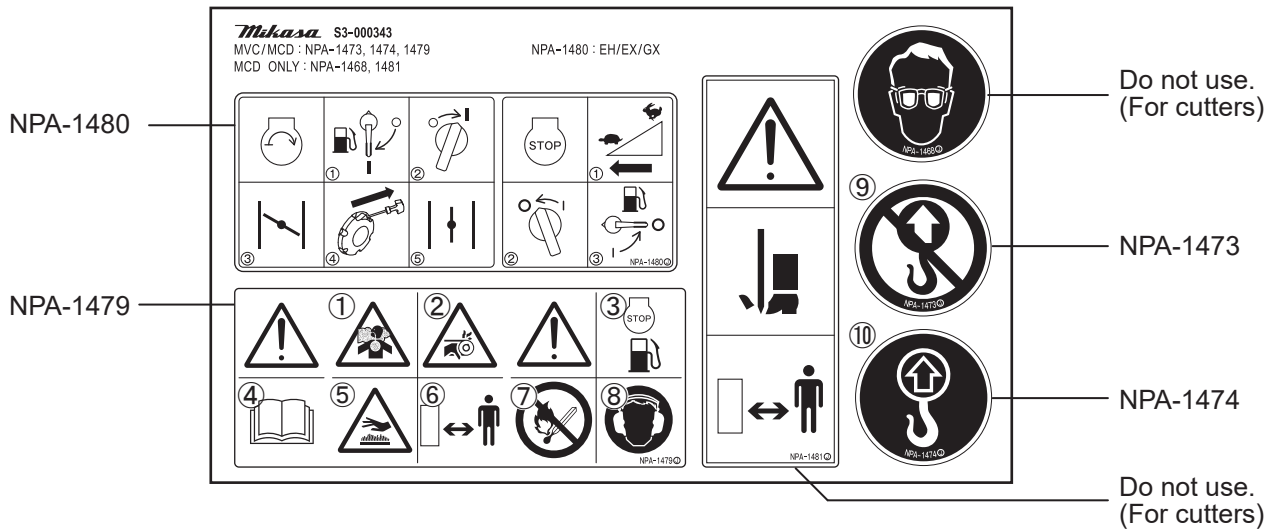

1 Lethal Exhaust Gas Hazard.
Carbon monoxide poisoning may occur if the exhaust gas is inhaled. Do not operate the machine in a poorly ventilated area.



2 Rotating Parts Hazard.
Keep hands clear from all moving parts (such as inside the belt cover) to prevent injury.



3 Refueling Hazard.
Stop the engine and let cool before refueling.



4 Read the manual carefully.
Read and fully understand the operation manual before operating the machine.



5 Burn Hazard.
Never touch the hot parts. Allow these parts to cool before servicing the machine.

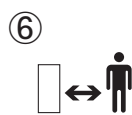

6 Keep safe distance.
Be careful not to approach danger source during operation.



7 Fire hazard.
Be careful of any flames while operating, storing and refueling.



8 Noise hazard.
Always wear ear protection while operating the machine.



9 No lifting position.
Do not use any other points (such as the handle) except one point lifting hook for lifting the machine.



10 Lifting position.
Use one point lifting hook for lifting the machine.

Starting and stopping for gasoline engine

START

- ① Open Fuel Cock to start.
- ② Turn Stop Switch to "I"(ON) position.
- ③ Close Choke Lever.
- ④ Pull Recoil Starter to start the engine.
- ⑤ Return Choke Lever to open.

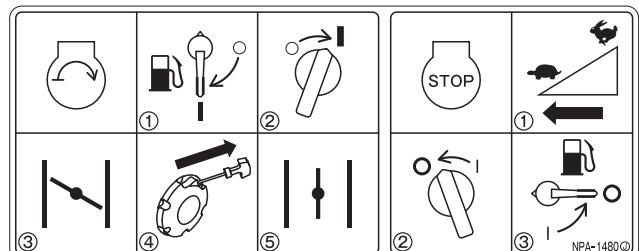

STOP

- ① Return Throttle Lever fully until "O"(OFF) position to stop work.
- ② After cooling down enough, turn Stop Switch to "O"(OFF) position to stop the engine.
- ③ Close Fuel Cock at the end.

5. SPECIFICATIONS

Model	MVC-T60H VAS	
Weight		
Operating Weight (with Water Tank)	75 kg (165 lbs.)	
Operating Weight (without Water Tank)	69 kg (152 lbs.)	
Dimensions (Including Handle)	Operation position	Storage position
Overall Length	980 mm (38.6 inch)	663 mm (26.1 inch)
Overall Width	350 mm (13.8 inch)	350 mm (13.8 inch)
Overall Height	1005 mm (39.6 inch)	596 mm (23.5 inch)
Plate Size		
Length	520 mm (20.5 inch)	
Width	350 mm (13.8 inch)	
Performance		
Vibrating Frequency	97 Hz (5800 V.P.M.)	
Centrifugal Force	10.3 kN / 1050kgf (2315 lbf.)	
Max. Traveling Speed	25 m/min (82 ft./min)	
Max. Area of Compaction	525 sq. m/hour (5651 sq. ft./hour)	
Vibrator		
System	Single Shaft Vibrator	
Oil Grade	API CD or later SAE10W-30	
Oil Capacity	0.3 liters (0.32 qt.)	
Standard Equipment		
	VAS Folding Handle	
	Water Tank : 8.5 liters (8.9 qt.)	
	Hour & Tachometer	
	Revolving Cart	
Power Source		
Manufacturer	HONDA	
Model	GX120	
Engine Type	Air-cooled, 4-stroke Gasoline	
Max. Output	2.4 kW (3.3 HP) / 3600 rpm	
Operating Engine Speed	3600 rpm	
PTO Shaft	Metric	
Starter	Recoil	
Fuel Tank Capacity	2.0 liters (0.53 gal.)	
Engine Oil Grade	API SE or later SAE10W-30	
Engine Oil Capacity	0.56 liters (0.59 qt.)	

- ※ Weight includes weight of machine, lubricants, 50% of fuel tank and 50% of water in case with water tank.
- ※ VAS Folding Handle: Vibration Absorbing System Folding Handle.
- ※ Specifications are subject to change without notification.

6. APPEARANCE

6.1 Overall Dimensions

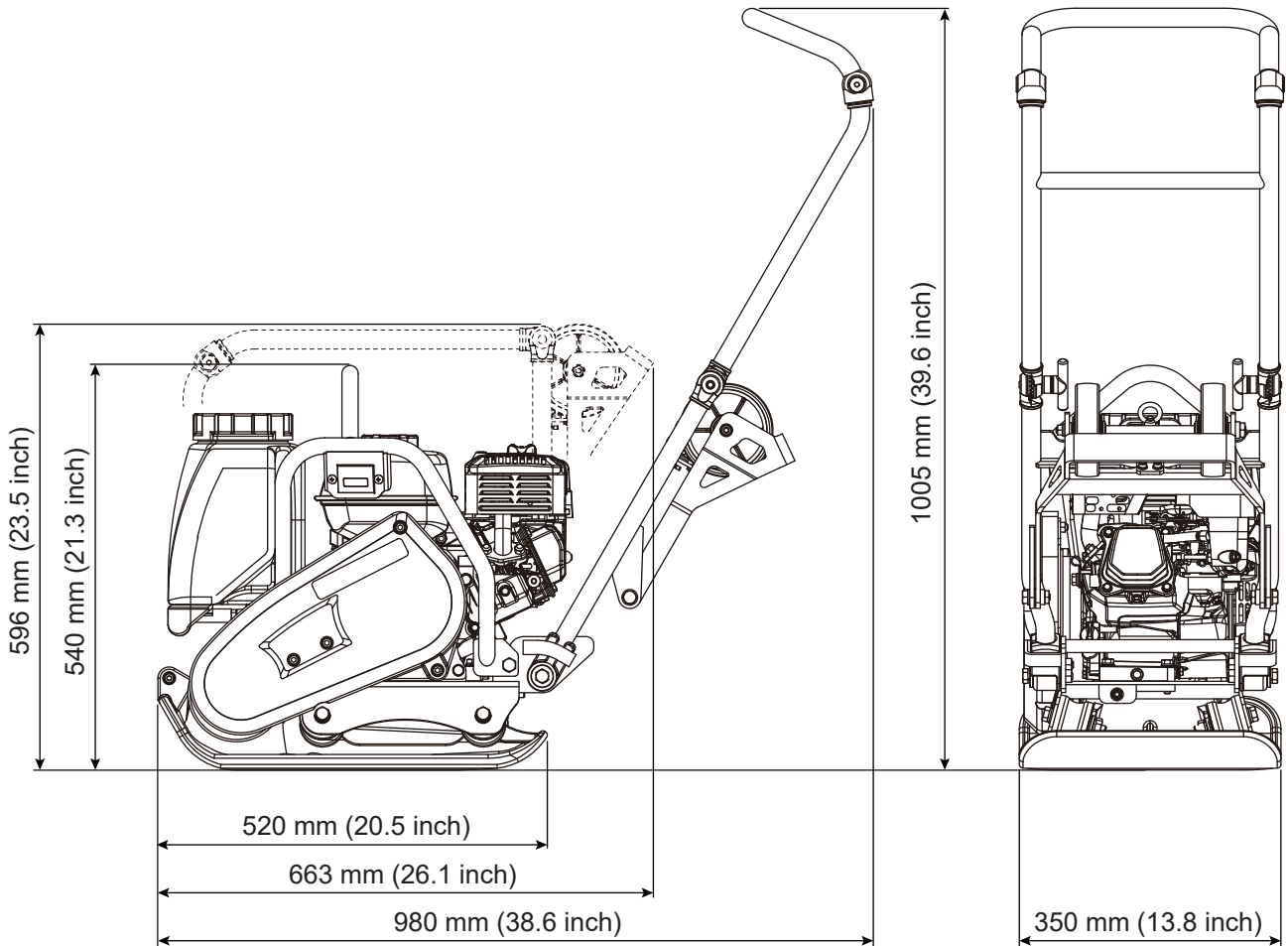

6.2 Control Unit Positions And Names

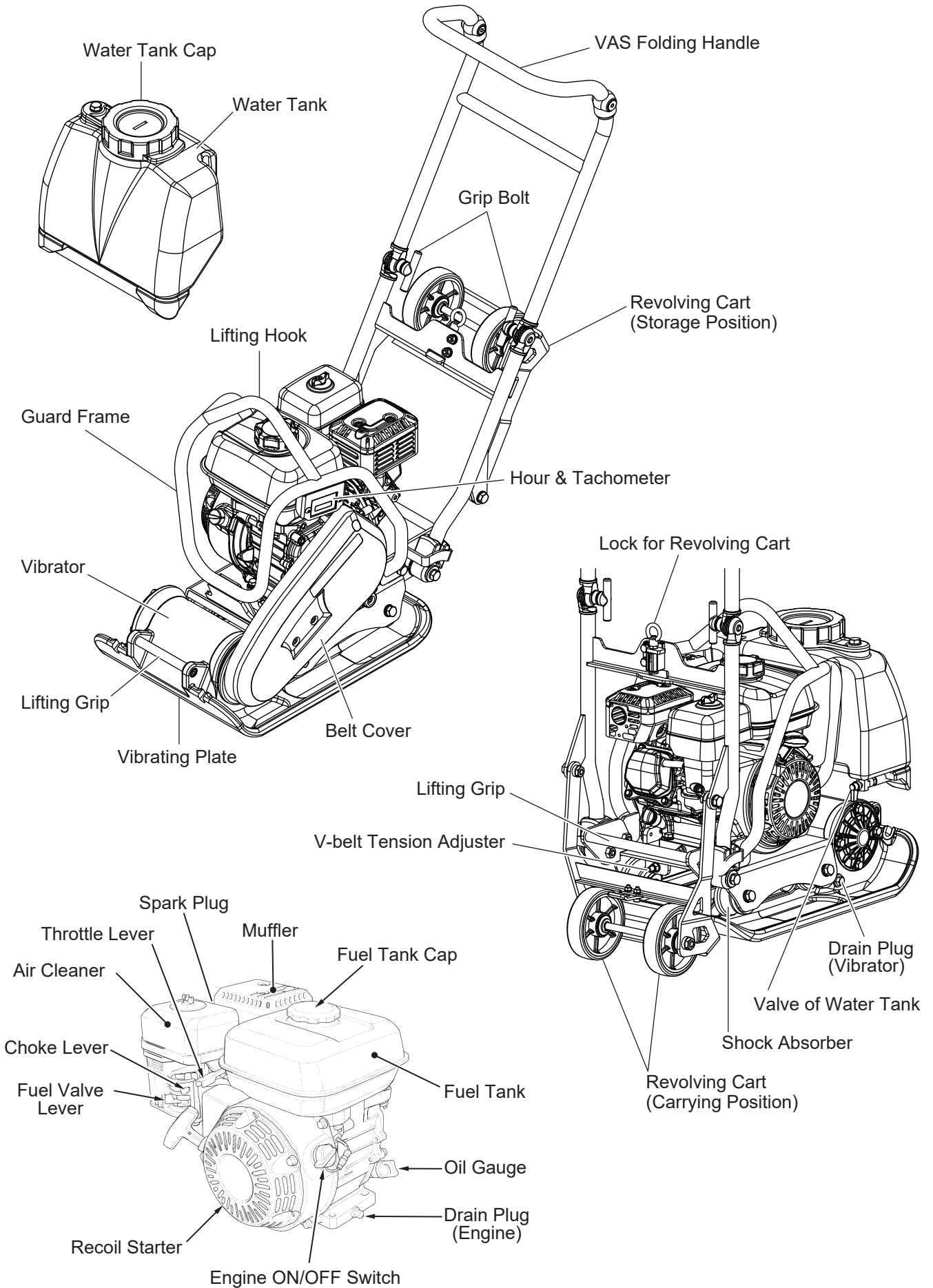

7. INSPECTION BEFORE OPERATION

Part inspection sheet before work start

Check point	Check item
Visual inspection	Flaw, Deformation, Breakage, Crack
Fuel tank	Leak, Level, Dirt
Fuel system	Leak
Fuel filter	Dirt
Engine oil	Leak, Level, Dirt
Vibrator oil	Leak, Level, Dirt
V-belt	Wear, Crack, Tension
Bolts & Nuts	Looseness, Falling off

※ Regarding the engine inspection, refer to the engine operation manual.

CAUTION Always stop the engine and allow it to cool before inspection and set the machine on hard and level ground.

7.1 Before Starting

1. Read all safety instructions at the beginning of manual.
2. Clean the machine, removing dirt and dust, particularly the engine cooling air inlet, carburetor and air cleaner.
3. Check the air filter for dirt and dust. If air filter is dirty, replace air filter with a new one as required. (P16, Fig. 20)
4. Check the carburetor for external dirt and dust. Clean with dry compressed air.
5. Check all bolts and nuts for tightness. Retighten them as necessary.

7.2 Engine Oil Check

1. Check the engine oil level. If the oil level is low, refill the oil. (Fig. 1)
Use the following engine oil.

Oil grade: API SE or later SAE10W-30
Refer to the following table for viscosities depending on ambient temperature.

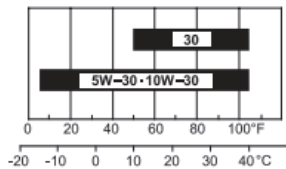

Oil capacity: 0.56 liters (560 cc)

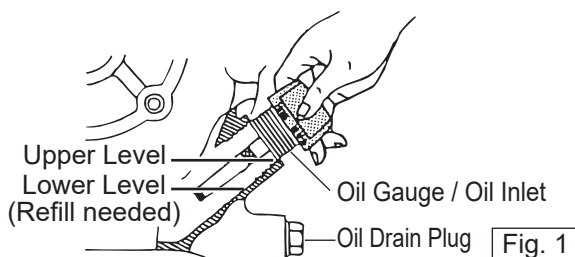

Fig. 1

7.3 Vibrator Oil Check

1. Check the vibrator oil level by removing the drain plug. Make sure the oil level is set at level of drain plug hole. (Fig. 2)
Use the following engine oil.

Oil grade: API CD or later SAE10W-30
Oil capacity: 0.3 liters (300 cc)

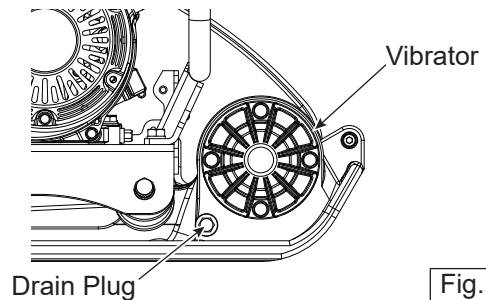

Fig. 2

7.4 V-Belt Check

1. Visually check the V-belt condition. If it determines cracks, wears and any other damages of the V-belt, replace the V-belt with a new one as required.
2. Check the V-belt tension. The V-belt tension is proper if the V-belt bents 10 to 15 mm when depressed with finger at midway between the clutch and vibrator pulley. (Fig. 3)

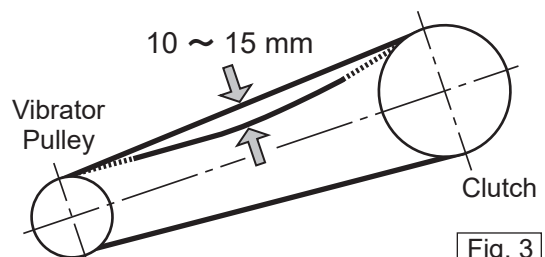

Fig. 3

- If the V-belt tension is not proper, adjust the V-belt tension. Slacken the four bolts fixed the engine and turn the nut for the V-belt tensioner until the V-belt tension is correct. Retighten the bolts and recheck the tension and alignment. (Fig. 4)

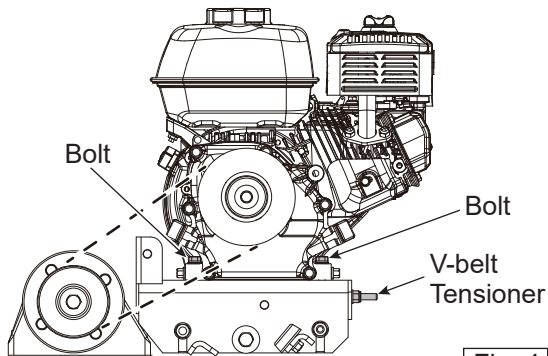

Fig. 4

7.5 VAS Folding Handle Check

- Check the VAS folding handle to fix at storage or operation position. When fixing the handle position, tighten the grip bolts certainly. (Fig. 5)

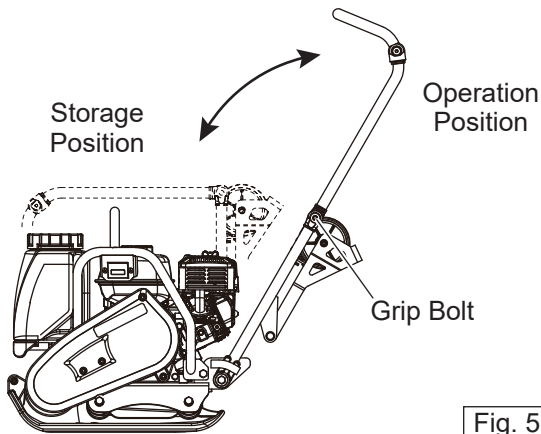

Fig. 5

7.6 Revolving Cart Check

- Check that the lock for revolving cart lock and unlock certainly. (Fig. 6)

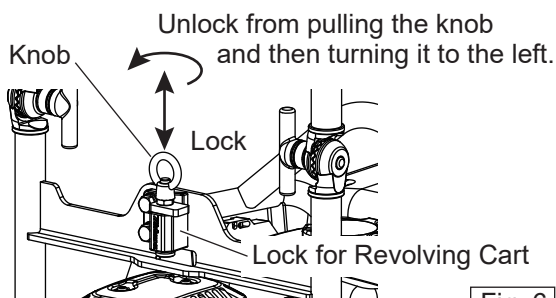

Fig. 6

- Check that the revolving cart move from storage position to carrying position smoothly. (Fig. 7)

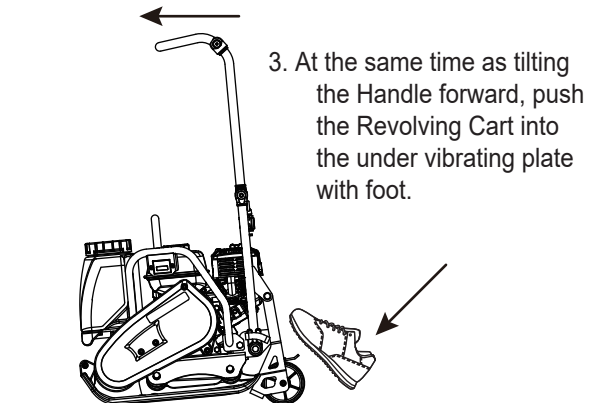
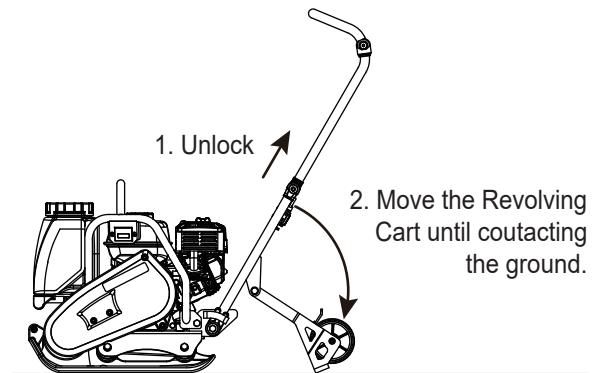

Fig. 7

- Check that the cart rotates smoothly by moving the machine forward and backward. (Fig. 8)

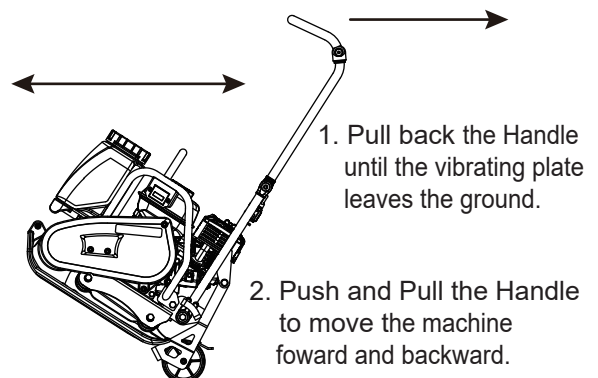

Fig. 8

CAUTION

- Do not get oil and gasoline on the cart. Oil and gasoline cause the rubber to swell and deteriorate. If contaminated with oil or gasoline, immediately clean the cart.

7.7 Fuel Check

1. Visually check fuel level. If fuel level is low, refuel with unleaded fuel. (Fig. 9)
2. When refueling, be sure to use a strainer for filtration.

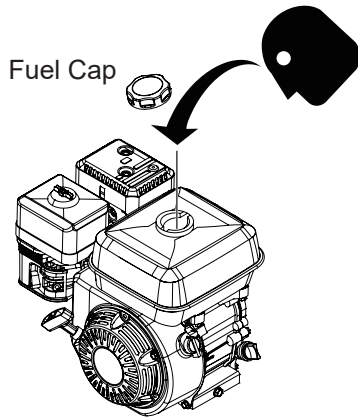

Fig. 9

⚠ DANGER

- Stop the engine when refueling.
- Never refueling near a naked flames or a source of sparks.
- Do not fill the fuel tank completely because the fuel might spill.
- Wipe up any spilled fuel.

7.8 Water Tank Check

1. Check the water tank for leaks after filling the water. (Fig. 10)

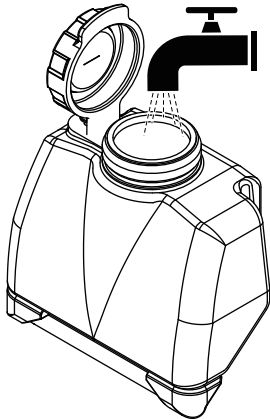

Fig. 10

2. Check the valve of water tank ON and OFF. (Fig. 11)

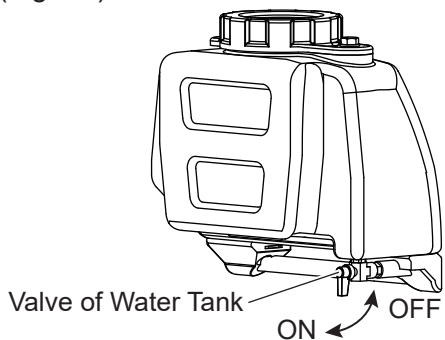

Fig. 11

8. OPERATION

8.1 Starting

1. Move the VAS folding handle from storage position to operation position, then fix the handle position by tightening the grip bolts.
2. Move the fuel cock lever to the "ON" position. (Fig. 12)

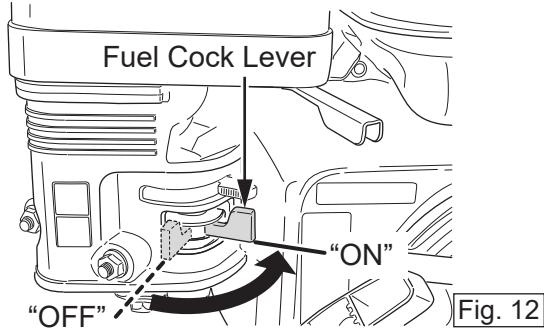

Fig. 12

3. To start a cold engine, move the choke lever to the "CLOSED" position. To restart a warm engine, leave the choke lever in the "OPEN" position. (Fig. 13)

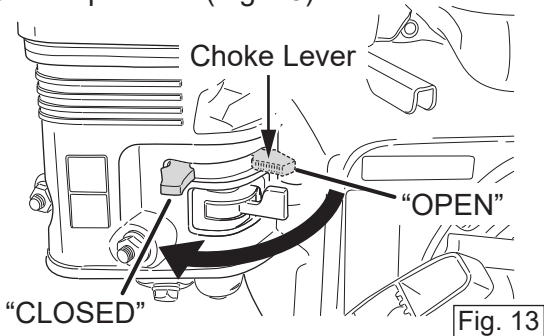

Fig. 13

4. Move the throttle lever to the idle position. (Fig. 14)

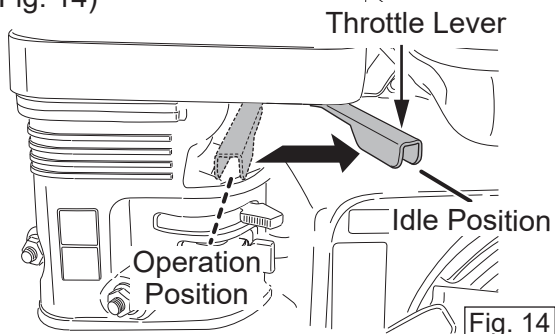

Fig. 14

5. Turn the engine switch to the "ON (I)" position. (Fig. 15)

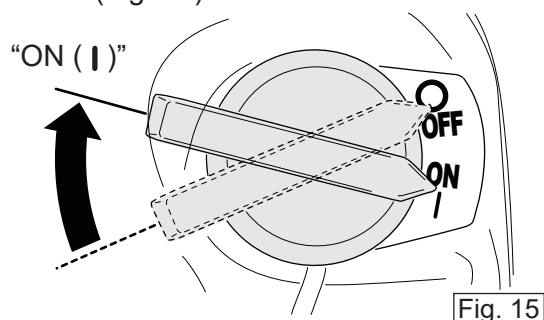

Fig. 15

6. Pull the starter grip lightly until you feel resistance. Then, pull it briskly in the direction of the arrow as shown below. (Fig. 16)

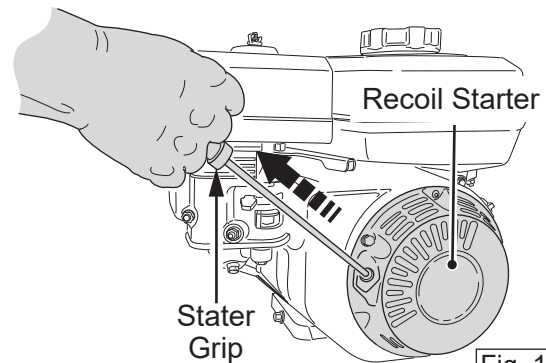

Fig. 16

CAUTION

- Do not pull the starter grip all the length of the rope.
- Be careful not to pull it too hard as it might break or come off.
- Return it gently to prevent damage to the recoil starter.

7. If the choke lever has been moved to the "CLOSED" position to start the engine, gradually move it to the "OPEN" position as the engine warms up. (Fig. 17)

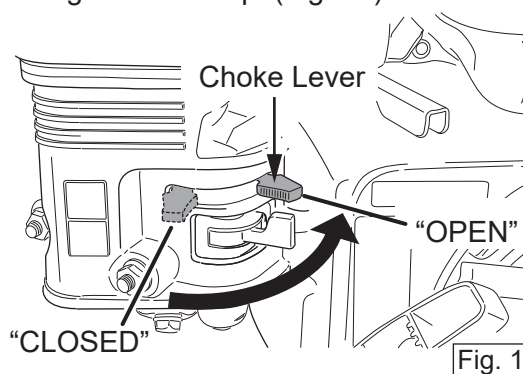

Fig. 17

8. After the engine has started, warm up the engine at idle speed for 2 to 3 minutes. This is especially important in cold weather.

CAUTION

- When starting the cold engine, if the throttle lever is moved from the idle position about 1/3 of the way to the operation position, the centrifugal clutch may slip as soon as the engine has started. This may cause a failure of the centrifugal clutch, abnormal vibration of the machine, which is very dangerous. So, as soon as the engine has started, return the throttle lever to the idle position.

8.2 Operation

⚠ WARNING

- During operation, pay sufficient attention to dangerous objects and obstacles in the direction of your work and surrounding area.
- During operation, never touch the moving parts and high temperature parts of the machine.

1. Once the engine has started, when moving the throttle lever quickly to the operation position, the machine starts vibration. (Fig. 18)

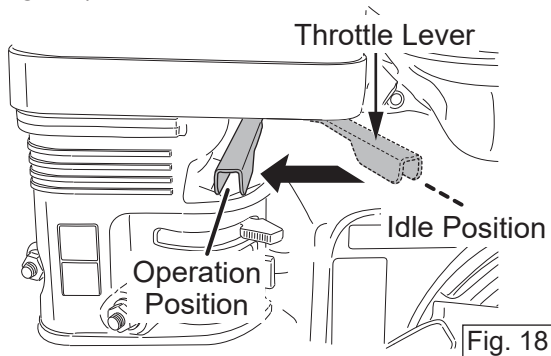

⚠ CAUTION

- Always move the throttle lever quickly without hesitation, because increasing the engine speed slowly causes the clutch slipping.

2. When suspending the work, return the throttle lever to the idle position quickly.

⚠ CAUTION

- When this machine is used on ground that contains clay or high water percentage, the ground surface tends to stick to the vibrating plate, and the machine may slow down or not compact.

In this case, check the bottom of the vibrating plate to see if there is adhered any clay to it.

Dry the ground until becoming the appropriate ground condition before using this machine to get good compaction performance.

9. STOPPING THE MACHINE

⚠ CAUTION

- Never stop the engine suddenly while working at high speed.

1. Move the throttle lever to the idle position. Cool down the engine for 3 to 5 minutes at idle speed before stopping. (Fig. 19)

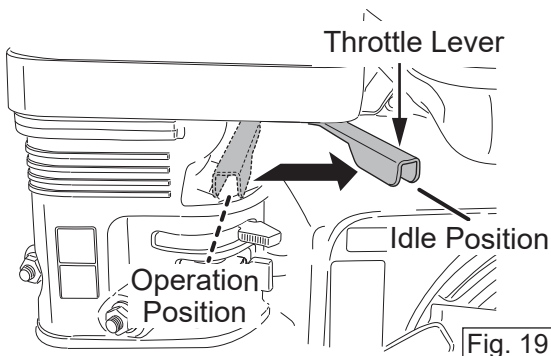

3. Move the fuel cock lever to the "OFF" position. (Fig. 21)

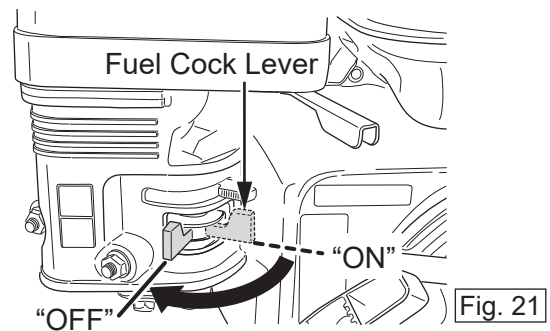

⚠ WARNING

- When moving away from the machine, stop the engine and make sure that the machine is completely tied down.

2. Turn the engine switch to the "OFF (O)" position. (Fig. 20)

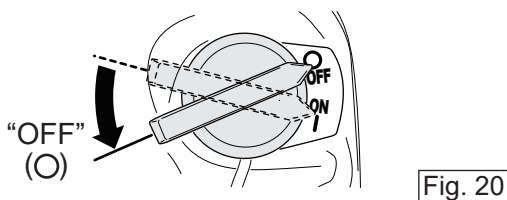

10. TRANSPORTATION

10.1 Loading And Unloading

WARNING

- Make sure there is no breakage of guard frame and shock absorbers nor loosened or missing bolts.
- Always stop the engine when lifting. Use an intact lifting cable (wire or rope) without any deformation with sufficient strength.
- Slowly lift upward without applying any impact. Never let people or animals go under the lifted machine.
- For safety reasons, do not lift to a height that is higher than necessary.

1. Use a crane or lift for loading and unloading the machine.
2. Designate a person to guide the loading and unloading, and always work under the instruction of that person.
3. When lifting, always use the lifting hook. Never lift by using the handle as the lifting hook. (Fig. 22)

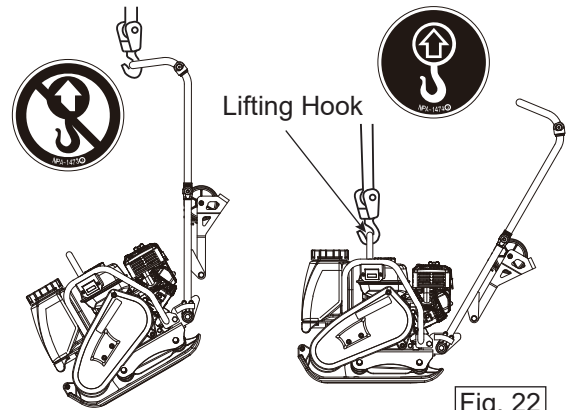

Fig. 22

10.2 Transportation

WARNING

- Stop the engine when the machine is transported.
- Always drain the fuel before transportation.
- Tie down the machine securely to prevent the machine from moving or falling.

11. STORAGE

- Wash off dirt and soil from all parts with water. While washing, be careful not to do the water splashed on the electric components such as the battery, the engine muffler and air cleaner.
- Store the machine on hard and level ground. Then, tie down the machine securely to prevent moving.
- Store the machine in a dry and clean place out of direct sunlight.
- Cover the machine to keep out dust.
- Do not leave the machine outdoors. Place the machine indoors.
- When not used for a long period of time, drain the fuel from the fuel tank and the carburetor.
- When the machine is used after a long storage period, check the engine oil condition and fill the fresh gasoline.

CAUTION

- Do not get oil and gasoline on the rubber parts such as the shock absorbers. Oil and gasoline cause the rubber to swell and deteriorate. If contaminated with oil or gasoline, immediately clean them.

12. REGULAR CHECK AND ADJUSTMENT

12.1 Inspection And Maintenance Schedule Table

Inspection interval	Check parts	Check items	Remarks
Daily (Before starting)	Visual inspection	Flaw, Deformation, Breakage, Crack	
	Fuel tank	Leak, Level, Dirt	Gasoline
	Fuel system	Leak, Dirt, Clog	
	Air cleaner	Dust, Dirt	
	Engine oil	Leak, Level, Dirt	Engine oil
	Vibrator oil	Leak, Level, Dirt	Engine oil
	V-belt	Wear, Crack, Tension	
	Lifting hook	Breakage, Crack, Looseness	
	Lifting grip	Breakage, Crack	
	Shock absorber	Crack, Damage, Wear	
	Bolts and nuts	Looseness, Falling off	
Every 20 hours	Engine oil	Change only after the first 20 hours	Engine oil
	Engine oil filter	Change only after the first 20 hours	
Every 100 hours	Engine oil	Change	Engine oil
	Engine oil filter	Washing	
	Vibrator oil	Leak, Level, Dirt	
Every 200 hours	V-belt	Tension, Crack, Wear, Failure	
	Clutch	Wear, Failure	
Every 300 hours	Vibrator oil	Change	Engine oil
	Fuel filter	Change	
	Engine oil filter	Change	
Every 2 years	Fuel lines	Change	
Irregular	Air cleaner element	Change	

For details about the inspection and maintenance of the engine, please refer to the attached engine operation manual.
Caution: The above table shows the inspection interval under normal condition.

The inspection interval may vary depending on the condition in which the machine is used.

For check of bolt and nut looseness and tightening, please see the following standard tightening torque table.

Standard tightening torque table (unit: kgf·cm, 1 kgf·cm = 9.80665 N·cm)

		Bolt size							
		6 mm	8 mm	10 mm	12 mm	14 mm	16 mm	18 mm	20 mm
Material	4T (SS400)	70	150	300	500	750	1,100	1,400	2,000
	6-8T (S45C)	100	250	500	800	1,300	2,000	2,700	3,800
	11T (SCM435)	150	400	800	1,200	2,000	2,900	4,200	5,600
	In case counterpart is of aluminum.	100	300~350	650~700					

- Bolt threads used with this machine are all right-hand screw.
- Material and quality of material is marked on each bolts.

CAUTION

- Always stop the engine before maintenance and set the machine on hard and level ground.
- Start your work after the machine and engine cool down completely.

12.2 Change The Engine Oil

- Change the engine oil, first in 20 hours of operation and every 100 hours afterwards. (P10, Fig. 1)

12.3 Clean The Air Cleaner

- When the air cleaner element becomes dirty, the engine will not start smoothly, and will not get sufficient output. It will affect the machine operation and will short the engine life greatly.
- Do not forget to clean the element. (For details, please see the separate engine operation manual.)
- If the element cannot be cleaned, replace it with a new one. (Fig. 23)

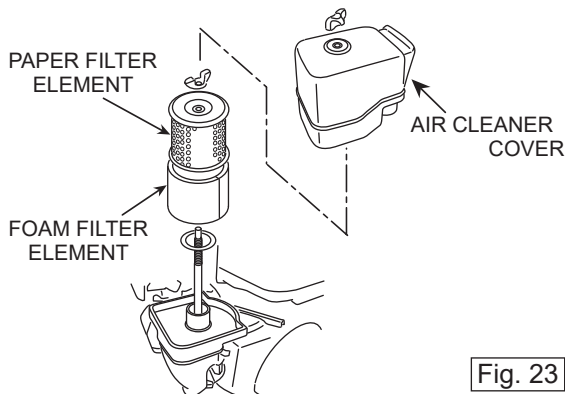

Fig. 23

12.4 Check / Change The Vibrator Oil

- At every 100 hours of operation, check that the vibrator oil level is correct by removing the drain plug. (P10, Fig. 2)
- At every 300 hours of operation, change the vibrator oil. For draining the oil from the port of the drain plug, tilt the machine with a sleeper or the like placed under the rubber rolls or use the oil changer.

CAUTION

- Do not overfill.
- After draining the vibrator oil, some oil still remains in vibrator case. So be sure to check that the oil level is correct after filling oil.

12.5 Check / Change The V-belt

- Every month or every 200 hours of operation, visually check the V-belt condition. If it determines cracks, wears and any other damages of the V-belt, replace the V-belt with a new one as required.
- Check the V-belt tension. The V-belt tension is proper if the V-belt bents 10 to 15 mm when depressed with finger at midway between the clutch and vibrator pulleys. (P10, Fig. 3)
- If the V-belt tension is not proper, adjust the V-belt tension. Slacken the four bolts fixed the engine and turn the nut for the V-belt tension adjuster until the V-belt tension is correct. Retighten the bolts and recheck the tension and alignment. (P11, Fig. 4)

12.6 Check / Change The Clutch

- Check the clutch concurrently with the checking the V-belt.
- Visually check for burning of the clutch shoes, wearing of the clutch linings and condition of the V-groove pulley.
- If the clutch linings wear, the clutch slips and power transmission is not performed properly. Replace the clutch with a new one as required.

13. TROUBLE SHOOTING

13.1 Gasoline Engine

(1) Starting problems

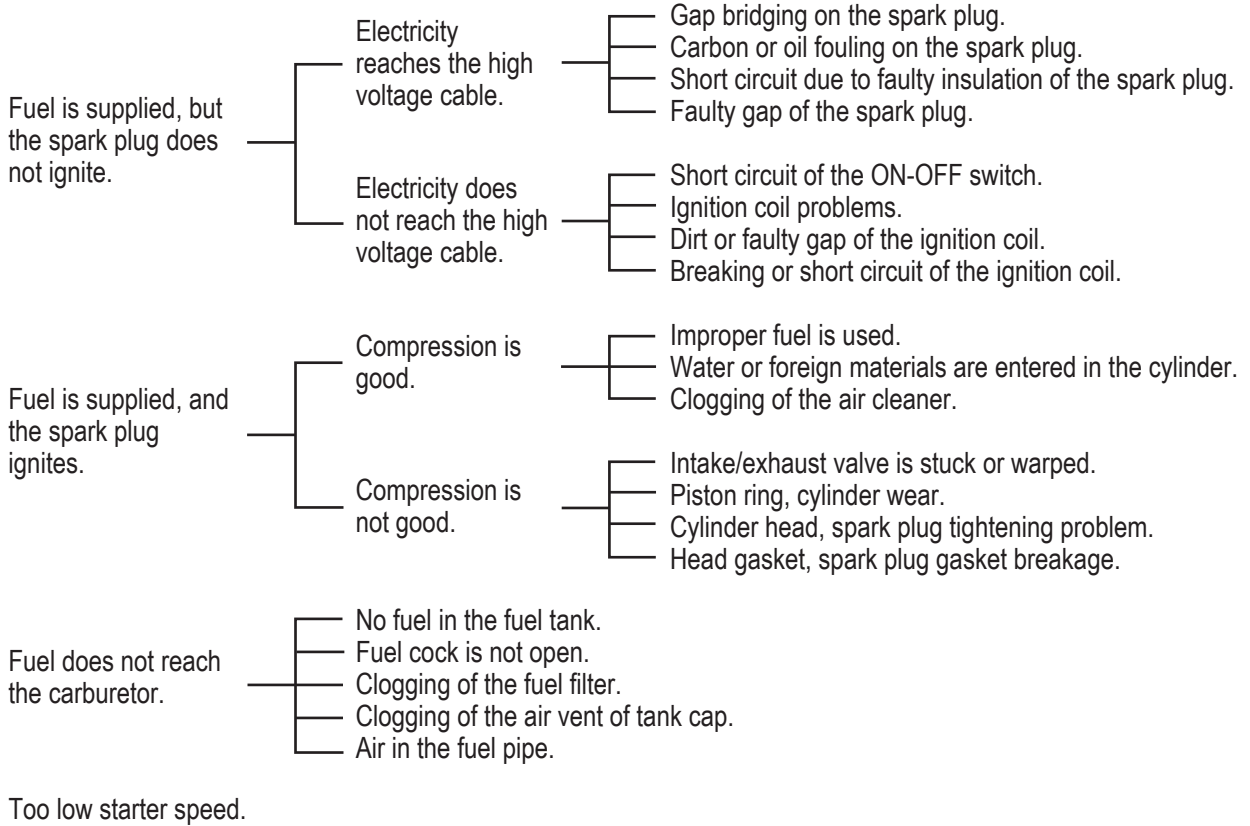

(2) Operation problems

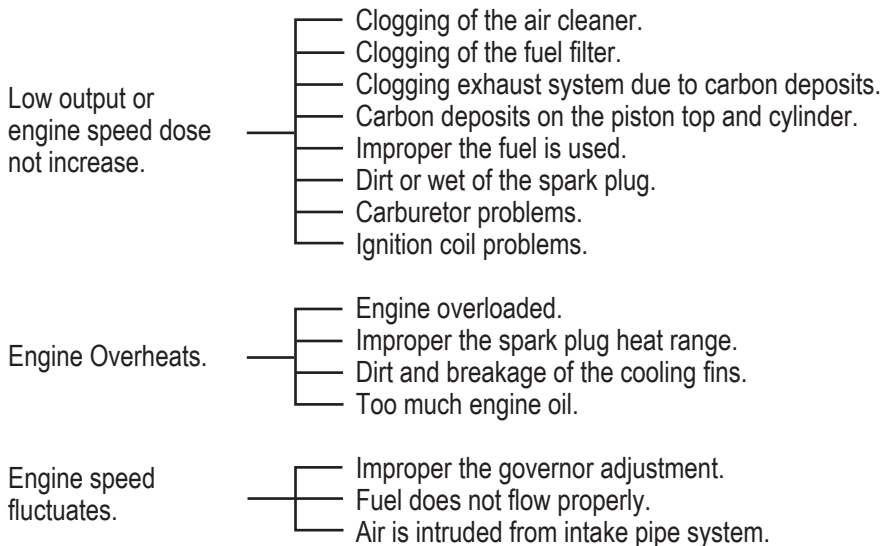

(3) Recoil starter problems

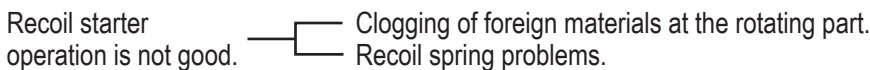

13.2 Main Body

- Vibration is weak.
- Insufficient the engine output.
 - Improper operating speed of the engine.
 - Slipping of the clutch.
 - Slipping of the V-belt.
 - Damage or deterioration of the shock absorber.
 - Too much the vibrator oil.
 - Failure inside the vibrator.
- No Vibration.
- No Fuel.
 - Brekage or coming off of the V-belt.
 - Brekage or slipping of the clutch.
 - Brekage of the vibrator.

Mikasa

MIKASA SANGYO CO., LTD.

1-4-3, Kanda-Sarugakucho, Chiyoda-ku, Tokyo, 101-0064, Japan

COPYRIGHT 2024, MIKASA SANGYO CO., LTD.