

Mikasa

PLATE COMPACTOR

MVC-40H
MVC-50H
MVC-T90H
MVC-T100D

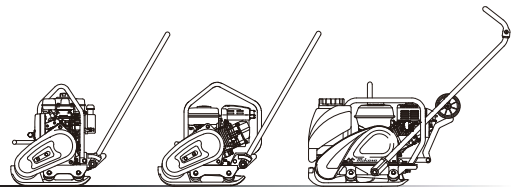

OPERATION MANUAL

en



<http://www.mikosas.com>

402-11802



TABLE of CONTENTS

1.	Preface	1
2.	Applications, Warnings, Structure and Power Transmission	1
3.	Warning Symbols	2
4.	Safety Precautions	2
	4. 1 General Precautions	2
	4. 2 Refueling Precautions	2
	4. 3 Location and Ventilation Precautions	3
	4. 4 Precautions Before Starting	3
	4. 5 Precautions During Work	3
	4. 6 Lifting Precautions	3
	4. 7 Transportation and Storage Precautions	4
	4. 8 Maintenance Precautions	4
	4. 9 Labeling Position	5
	4.10 Description of Symbols used Warning Labels	7
5.	Specifications	8
6.	Appearance	10
	6. 1 Overall Dimensions	10
	6. 2 Control Unit Positions and Names	12
7.	Inspection Before Operation	14
8.	Operation	16
	8. 1 Starting	16
	8. 2 Operation	18
9.	Stopping Machine	20
10.	Transportation	21
	10. 1 Loading and Unloading	21
	10. 2 Transportation Precautions	21
11.	Storage	21
12.	Regular Check and Adjustments	22
	12. 1 Inspection and Maintenance Schedule Table	22
	12. 2 Changing Engine Oil	23
	12. 3 Cleaning Air Cleaner	23
	12. 4 Checking/Changing V-belt and Clutch	23
	12. 5 Inspection and Change of Vibrator Oil	23
13.	Troubleshooting	24

1. Preface

- This operation manual describes the proper operation, basic inspection and maintenance procedures of the plate compactor. Please read this operation manual before use in order to maximize the excellent performance of this machine and make your work more efficient and effective.
- After reading the manual, please keep it in a handy location for easy reference.
- For the handling the engine, please refer to the separate engine operation manual.
- For inquiries about repair parts, parts lists, service manuals, and repairs, please contact the store where you purchased the product, our sales office, or the Mikasa Parts Service Center. For parts lists, please visit our homepage at: <http://www.mikasas.com/> where you can access Mikasa WEB parts lists.

The illustrations in this manual might slightly differ in part from the machine you actually purchased due to design changes.

2. Applications, Warnings, Structure and Power Transmission

Applications

Plate compactor is the machine that compacts the ground and it intends to make the surface smooth, by transmitting vibration through vibrating plate, which power generated from single rotor in vibrator case.

This machine is suitable for making the ground surface smooth, such as leveling the soil and beaching, finishing the asphalt paving.

Warning about incorrect applications and techniques

This machine is hard to move forward on a soil with much water (especially clay soil). It is not suitable for such application. This machine is difficult to level a ground include big stones due to insufficient compacting force. Plate compactor is mainly applied for compacting surface smooth and it is not effective for jobs that requires heavy compaction. In case of compacting ground deeply into lower layer, it is recommended to use Tamping Rammer, Vibro Compactor or Vibration Roller of which compacting force is rather effective. Please use this compactor for compacting surface on soil, sediment, beaching and asphalt. It is not recommended for use this machine for the other applications.

Structure

The upper part is made up of Power source, Handle, Belt Cover, Water Tank for sprinkling and Guard Hook which are fixed by Engine Base. The Engine base is fixed on Vibrating Plate by Shock Absorbing Rubber. The lower part is made up of Vibrating Plate and Vibrator Unit that has an Eccentric rotary shaft built in. The power source is transmitted from the centrifugal clutch on engine output shaft to the Eccentric rotary shaft through V-belt.

Power transmission

Air-cooled Single Cylinder Engine is amounted as power source and Centrifugal Clutch is fixed on engine output shaft.





Centrifugal Clutch engages by running up the engine and engine R.P.M. is reduced to suitable number for compacting. The rotation of engine is transmitted from V-pulley integrated with Clutch Drum to Vibrator Pulley through V-belt.

Vibrator Pulley rotates Eccentric Rotor Shaft that is contained in Vibrator Case. The generated vibration created from Eccentric Rotor is transmitted to Vibrating Plate.

Vibration of Vibrating Plate carries the machine forward; the vibration with the weight of the machine makes the compaction of the ground possible.







3. Warning Symbols

The triangle marks () used in this manual and on the decals on the machine are warning symbols. Please follow these precautions.

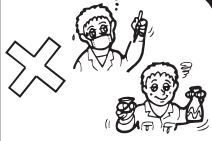

	Warning symbols indicating personnel hazards
	Extremely hazardous. If the warning is not followed, it is likely to result in serious injury or death.
	Hazardous. If the warning is not followed, it is likely to result in serious injury or death.
	Potential hazard. If the warning is not followed, it may result in injury.
Precautions (without  mark) If the warning is not followed, it may result in property damage.	

4. Safety Precautions



4.1 General Precautions

	<ul style="list-style-type: none"> ● Do not operate the machine, <ul style="list-style-type: none"> ○ If you do not feel well due to overwork or illness. ○ If you are taking any medicine. ○ If you are under the influence of alcohol. 	
	<ul style="list-style-type: none"> ● Read this manual carefully and handle the machine as described to ensure safe work. ● For details about the engine, refer to the separate manual for the engine. ● Make sure you understand the structure of the machine well. ● For safe work, always wear protective gear (helmets, safety shoes, ear plugs, etc.) and work in appropriate clothes. ● Always check the machine before your work to make sure it is in normal condition. ● Decals on the machine (operation method labels, warning labels, etc.) are very important for your safety. Keep the machine clean so that the decals can be read all the time. Replace a decal if it becomes illegible. ● Before performing maintenance work, be sure to turn the engine off. ● It is very dangerous if children come into close contact with the machine. Have the utmost concern about how and where to store the machine. In particular, for an engine with a cell, always remove the starter key and keep it in a designated place. ● Before inspection and maintenance work, stop the engine, and do your work on a flat surface area. If a cell is attached, remove the battery wiring before your work. ● Mikasa does not accept any responsibility for accidents caused by remodeling or rework done on the machine. 	   

4.2 Refueling Precautions

	<ul style="list-style-type: none"> ● When adding fuel, <ul style="list-style-type: none"> ○ Make sure you work in a well ventilated location. ○ Make sure the engine is stopped and wait until it cools down. ○ Take the machine to a clear flat location without any combustibles nearby. Be careful not to spill the fuel. Wipe well if any spill occurs. ● Do not fill to the rim due to potential spillage. After adding the fuel, tightly close the tank cap. 	 
---	--	--



4.3 Location and Ventilation Precautions

	<ul style="list-style-type: none"> ● Do not run the machine in an unventilated location, such as indoors or inside a tunnel. The exhaust gas from the engine contains toxic gases such as carbon monoxide and is very hazardous. ● Do not operate the machine near open flames. 	
---	---	---

4.4 Precautions Before Starting

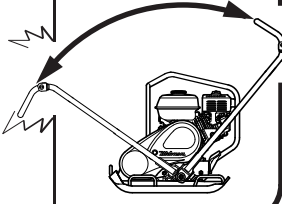

	<ul style="list-style-type: none"> ● Check each part to see if it is tightened properly. Vibration causes loosening of bolts, which results in unexpected serious malfunctions of the machine. Tighten the bolts securely. 	
---	---	--

4.5 Precautions During Work

	<ul style="list-style-type: none"> ● Before starting the machine, make sure it is safe to start by checking your surroundings for people and objects. ● Always pay attention to your footing. Work in an area where you can maintain a good balance of the machine and a safe comfortable posture. ● The engine and muffler become very hot. Do not touch immediately after the machine stops because they are still very hot. ● If you notice deterioration of machine operation during your work, stop your work immediately. ● Before moving away from the machine, be sure to turn the engine off. Also when the machine is transported, stop the engine and close the fuel cock. ● Keep its safety in turning a handle back and forth. An attached handle is movable. Keep its safety by clearing any obstacle in handle motion. In case of the operation turning a handle forward, move a handle down slowly by holding a handle, to resist its weight. 	  
---	--	--

4.6 Lifting Precautions



For unloading using a crane, a licensed crane operator is needed. An operator should be qualified for crane and hooking work.

	<ul style="list-style-type: none"> ● Before lifting, check the machine parts (especially the hook and anti-vibration rubber) for any damage and loosened or missing bolts. ● Stop the engine and shut the fuel cock while lifting. ● Use a wire rope with sufficient strength. ● For lifting, use only one point hoisting hook, and do not lift at any other part. ● When the machine is hoisted, never let people or animals come underneath. ● For safety reasons, do not lift to a height that is higher than necessary. 	
	<ul style="list-style-type: none"> ● Use lifting handles for lifting up by hand. In case of loading/unloading or lifting transportation by hand, hold each lifting handle or lifting edge securely located in vibrating plate. Do not use the operation handle for lifting up. This lifting handle is for manual lifting only. Do not use this lifting handle as a machine lift point. Use the lifting point on the top of the machine. 	

4.7 Transportation and Storage Precautions

	<ul style="list-style-type: none"> ● Stop the engine during transportation. ● Transport after the engine and the machine are cooled down. ● Always drain the fuel before transporting. ● Securely fix the machine to prevent it from moving or falling during transportation. 	
---	---	--

4.8 Maintenance Precautions

	<ul style="list-style-type: none"> ● Appropriate maintenance is required to ensure safe and efficient operation of the machine. Always pay attention to the machine's condition and keep it in good condition. Pay special attention to the parts used for lifting, if they are not maintained properly, it might result in a serious accident. ● Start maintenance work after the machine has cooled down completely. The muffler, in particular, becomes very hot, and there is a danger of burn. The engine, engine oil and vibrator also become very hot. Be careful not to get burned. 	
	<ul style="list-style-type: none"> ● Always stop the engine before inspection and adjustment. If you are caught in a rotating part, serious injury might occur. ● After maintenance work, check the security parts to see if they are securely installed. Special attention should be paid when checking bolts and nuts. ● If disassembly is involved in maintenance, refer to the maintenance instruction manual to make your work safe. 	

4.9 Labeling Position

MVC-40H

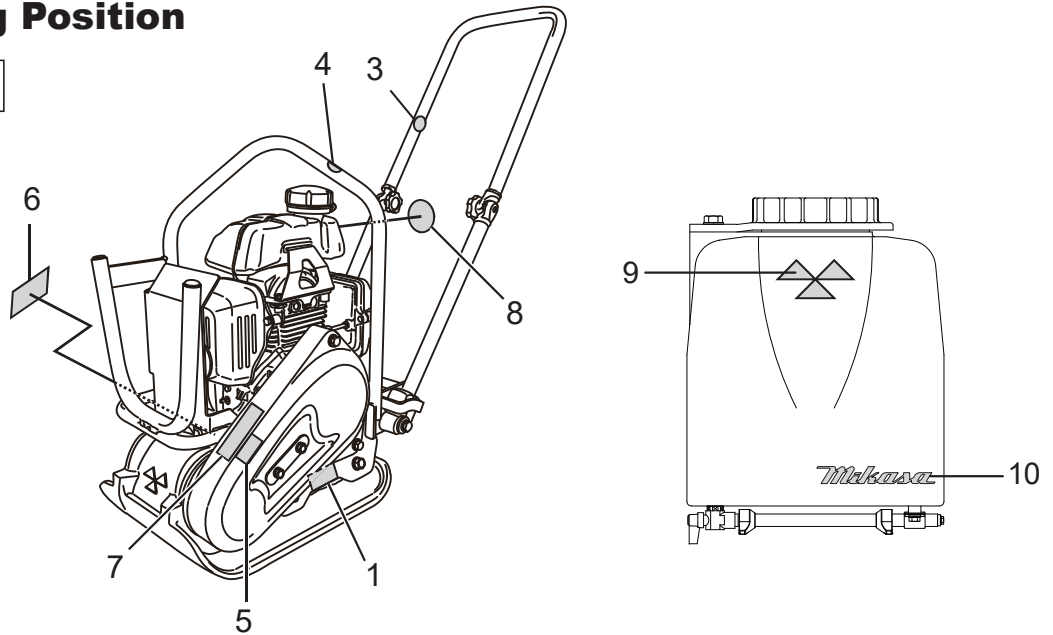

MVC-50H

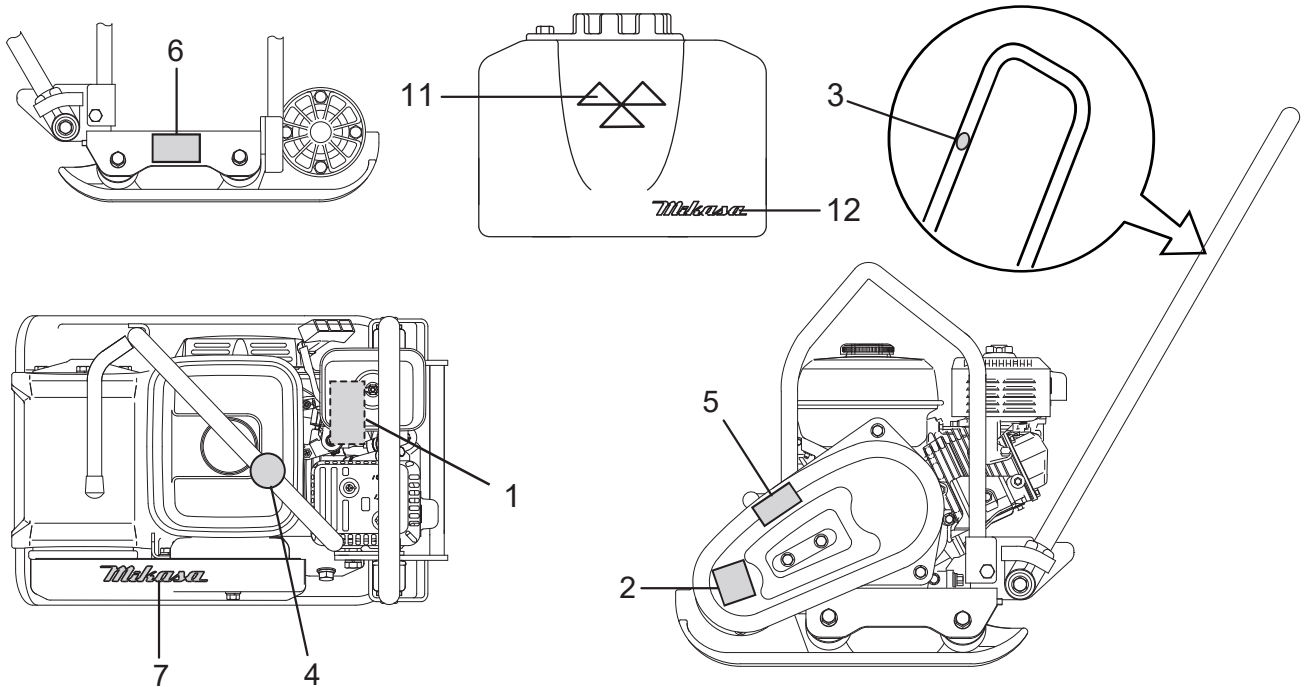

REF No.	PART No.	PART NAME	Q' TY	LABEL No.	REMARK
1	—	PLATE, SERIAL NO.	1	—	
2	9202-10330	DECAL,EC NOISE REQ.LWA105	1	NPA-1033	50H
3	9209-00090	DECAL,DO NOT LIFTING	1	NPA-1473	
4	9209-00090	DEAL,LIFTING POSITION	1	NPA-1474	
5	9209-00090	DEAL,CAUTION ICONS	1	NPA-1479	Warnig labels
6	9209-00090	DECAL,ENGINE HANDLING /GS	1	NPA-1480	Starting, and stopping
7	9201-13430	DECAL,MIKASA MARK 125MM	1	NP-1343	
8	9202-22810	EAR PROTECTION LABEL	1	NPA-2281	40H
9	9201-08850	DECAL,M-MARK Y-40X80	1	NP-885	40H WATER TANK
10	9201-13430	DECAL,MIKASA MARK 125MM	1	NP-1343	40H WATER TANK
11	9201-13140	DECAL, MIKASAMARK	1	NP-1314	50H/ WATER TANK
12	9201-14010	DECAL,MIKASA MARK 125MM	1	NP-1401	50H/ WATER TANK

MVC-T90
MVC-T100D

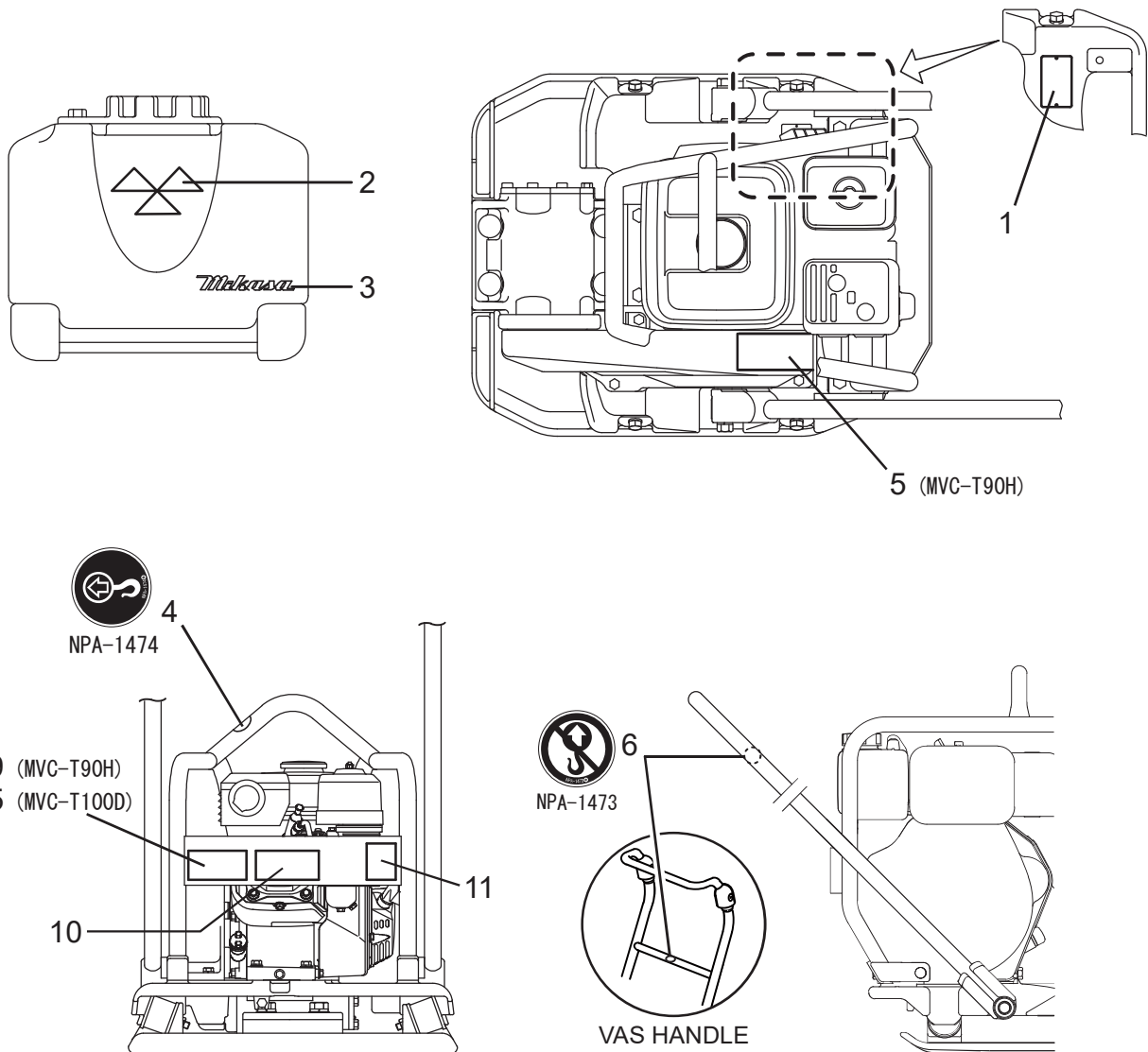







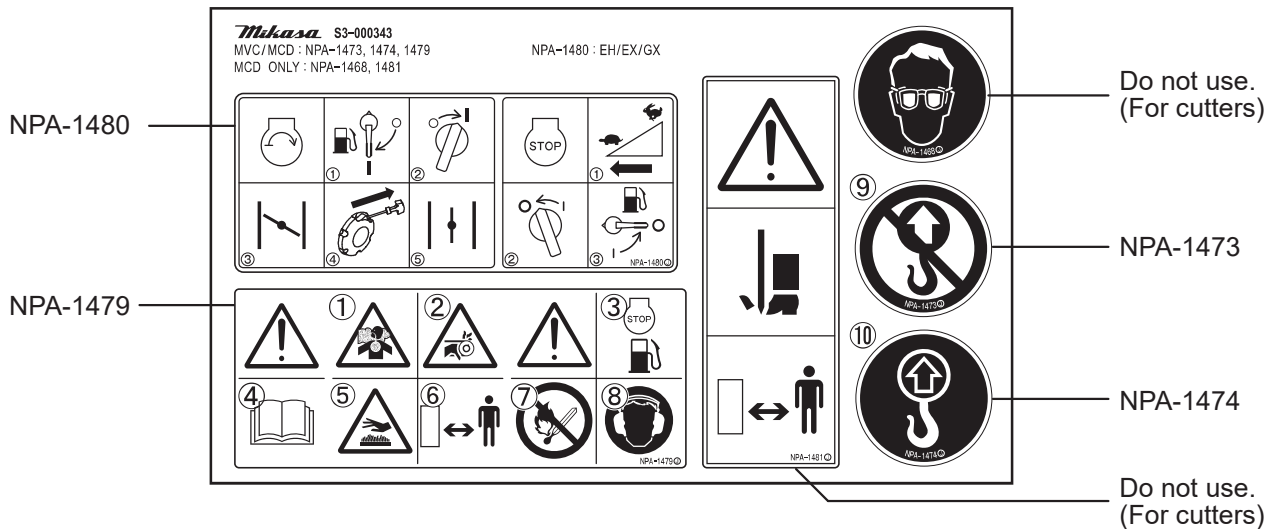

REF No.	PART No.	PART NAME	Q' TY	LABEL No.	REMARK
1	—	PLATE, SERIAL NO. / EU	1	—	
2	9201-13140	DECAL, MIKASAMARK	1	NP-1314	WATER TANK
3	9201-14010	DECAL,MIKASA MARK 125MM	1	NP-1401	WATER TANK
4	9209-00090	DEAL,LIFTING POSITION	1	NPA-1474	
5	9209-00090	DEAL,CAUTION ICONS	1	NPA-1479	Warnig labels
6	9209-00090	DECAL,DO NOT LIFTING	1	NPA-1473	
9	9209-00090	DECAL,ENGINE HANDLING /GS	1	NPA-1480	Starting, and stopping
10	9202-18170	DECAL,POSITION,APO./T90	1	NPA-1817	
11	9202-10330	DECAL,EC NOISE REQ.LWA105	1	NPA-1033	T90H
11	9202-10100	DECAL,EC NOISE REQ.LWA108	1	NPA-1010	T100D

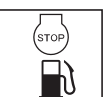
4-10. Descriptions of symbols used on warning labels

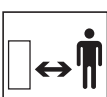
P/N 9209-00090 DECAL, SET /MVC, MCD /EXP,EU (NPA-1479, 1473, 1474)



- | | |
|---|---|
| <p>①  Danger: poisonous exhaust gas
Carbon monoxide poisoning may occur if the exhaust gas is inhaled. Do not operate the machine in a poorly ventilated area.</p> <p>②  Be careful not to get caught in the rotating parts.
During operation, be careful not to have your fingers, body, clothes, etc. come in contact with the rotating parts such as the V-belt and clutch.</p> <p>③  Refueling Hazard.
Don't fill the fuel tank while the engine is running or hot.</p> <p>④  Read the manual carefully.
Always read the operation manual and have good understanding of operation before your work.</p> <p>⑤  Be careful not to get burned.
Accidental burn may occur if you touch the hot parts (engine, muffler, etc.) during operation or immediately after the machine stops.</p> | <p>⑥  Be careful not to approach danger source.
During operation, Be careful not to approach hot parts and rotating parts.</p> <p>⑦  Fire hazard
Stop the engine when refueling. Fire may occur if a flame is near the tank fuel port.</p> <p>⑧  Danger of hearing damage caused by noise
Always use ear plugs while operating the machine.</p> <p>⑨  Do not lift the machine at this point.
Lifting by the handle is prohibited .</p> <p>⑩  Lifting position.
For lifting, use only one point hoisting hook, and do not lift at any other part.</p> |
|---|---|

Starting, and stopping

P/N 9209-00090 DECAL, SET /MVC, MCD /EXP, EU (NPA-1480 : MVC-T100D is excluded.)

START

- ① Open Fuel Cock to start
- ② Turn Stop Switch to "I"(ON) position
- ③ Close Choke Lever
- ④ Pull Recoil Starter to start
- ⑤ Return Choke Lever to open

STOP

- ① Return Throttle Lever fully until "O"(OFF) position to stop work
- ② After cooling down enough, stop the engine to move Stop Switch to "O"(OFF) position
- ③ Close Fuel Cock at the end

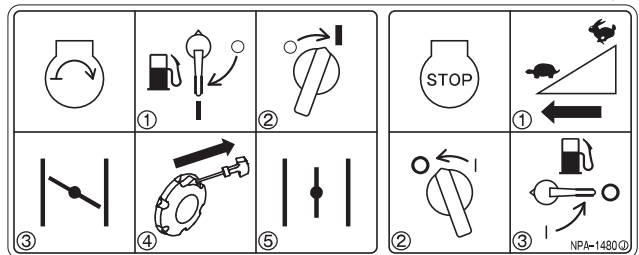

5. Specifications

Machine Specifications

Model		MVC-40H	MVC-50H	
Engine Model		Honda GX100	Honda GX120	
Type of Handle		FOLDING	STANDARD	FOLDING
Overall Length				
Without water tank	mm	910	915	880
With water tank	mm	1025	965	940
Overall Width	mm	295	345	←
Overall Height	mm	920	920	850
Plate Size (W x L)	mm	295 x 420	345 x 460	←
Operating Weight				
Without water tank	kg	50	59	60
With water tank	kg	56	65	66
Travelling Speed	m/min	25	←	←
Vibrating Frequency	Hz (vpm)	103 (6200)	97 (5800)	←
Centrifugal Force	kN (kgf)	7.2 (730)	9.8 (1000)	←
Vibrator Oil Grade		SAE 10W-30	←	←
Vibrator Oil Capacity	cc	300	←	←
Water Tank Capacity	liters	9	8.5	←
V-Belt Size		RPF3280	RPF3270	←

Engine Specifications

Manufacturer		Honda	Honda
Model		GX100	GX120
Type		Air-cooled, 4-stroke, gasoline	←
Max. Output		2.1kW (2.9PS) / 3600rpm	2.4kW (3.3PS) / 3600rpm
Fuel Tank Capacity	liters	0.77	2.0
Engine Oil Grade		API SE or later SAE10W-30	←
Engine Oil Capacity	cc	400	560
Starter		Recoil	←
Operating Engine Speed	rpm	3600	←

The specifications may be changed without notice.

Machine Specifications

Model		MVC-T90H		MVC-T100D	
Engine Model		Honda GX160		Yanmar L48N	
Type of Handle		STANDARD	VAS	STANDARD	VAS
Overall Length	mm	1100	1050	1100	1050
Overall Width	mm	500	←	500	←
Overall Height	mm	825	950	825	950
Plate Size (W x L)	mm	500 x 525	←	←	←
Operating Weight					
Without water tank	kg	91	94	103	106
With water tank	kg	101	104	113	116
Travelling Speed	m/min	25	←	←	←
Vibrating Frequency	Hz (vpm)	100 (6000)	←	←	←
Centrifugal Force	kN (kgf)	15.0 (1530)	←	←	←
Vibrator Oil Grade		SAE 10W-30	←	←	←
Vibrator Oil Capacity	cc	200	←	←	←
Water Tank Capacity	liters	13	←	←	←
V-Belt Size		RPF3330	←	RPF3380	←

※¹ VAS = Vibration Absorbing System

※² In case the above models equipped with folding cart, add 4kg to each operating weight.

Engine Specifications

Manufacturer		Honda	Yanmar
Model		GX160	L48N
Type		Air-cooled, 4-stroke, gasoline	Air-cooled, 4-stroke, diesel
Max. Output		3.6kW (4.9PS) / 3600rpm	3.5kW (4.7PS) / 3600rpm
Fuel Tank Capacity	liters	3.1	2.4
Engine Oil Grade		API SE or later SAE 10W-30	API CD or later SAE 10W-30
Engine Oil Capacity	cc	580	800
Starter		Recoil	Recoil
Operating Engine Speed	rpm	3600	3700

The specifications may be changed without notice.

6. Appearance

6.1 Overall Dimensions

MVC-40H

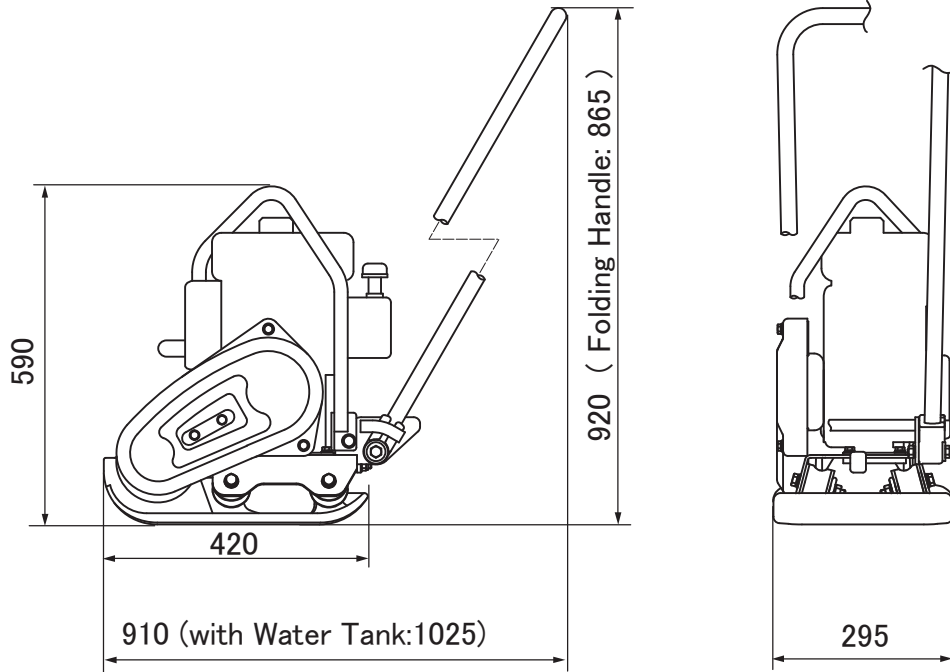

MVC-50H

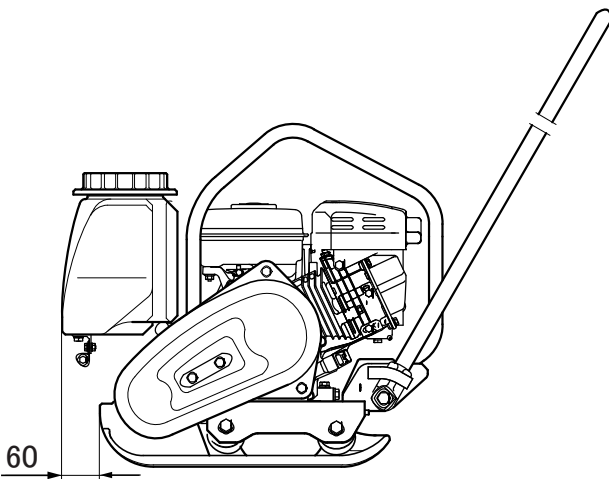
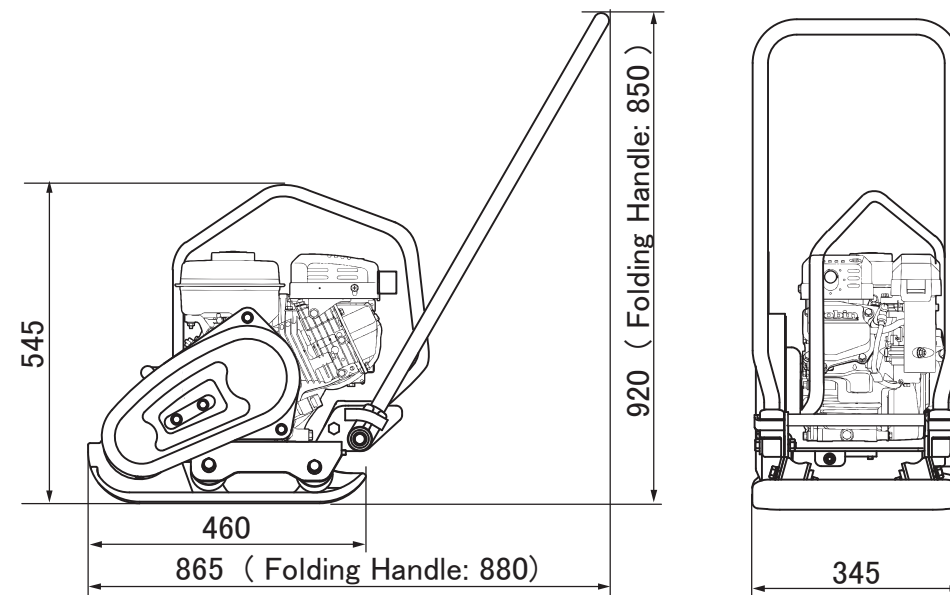

● Dimensions may change without notice.

MVC-T90H / T100D

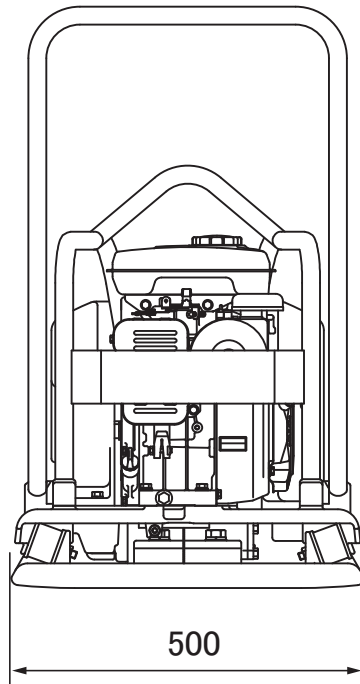
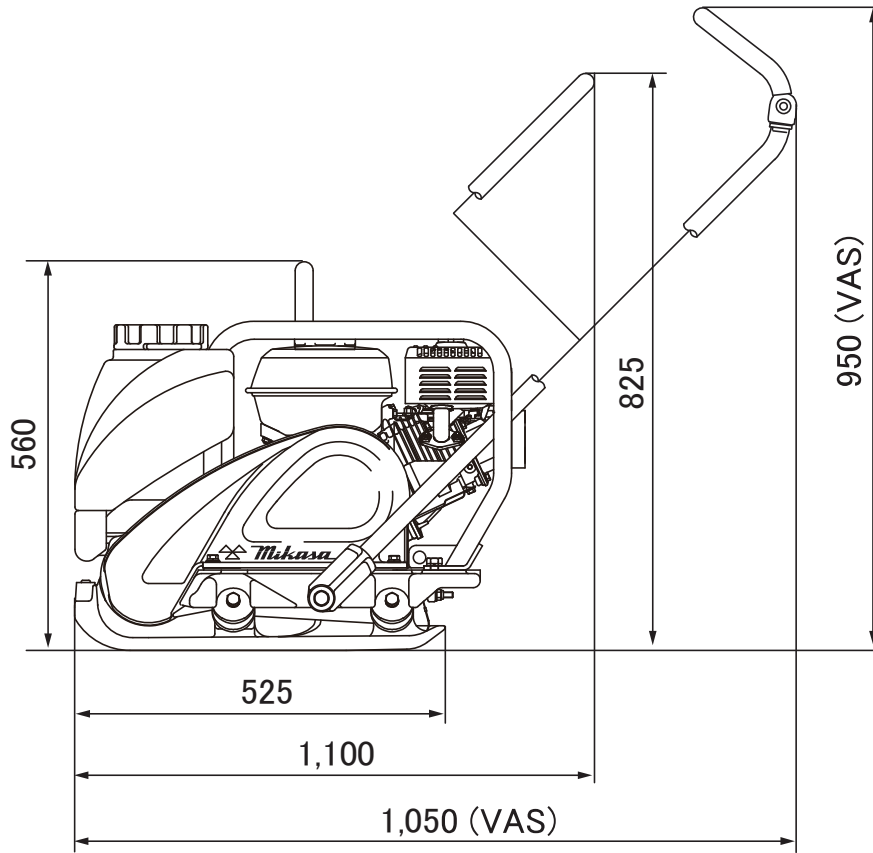

- VAS = Vibration Absorbing System
- Dimensions may change without notice.

6.2 Control Unit Positions and Names

MVC-40H

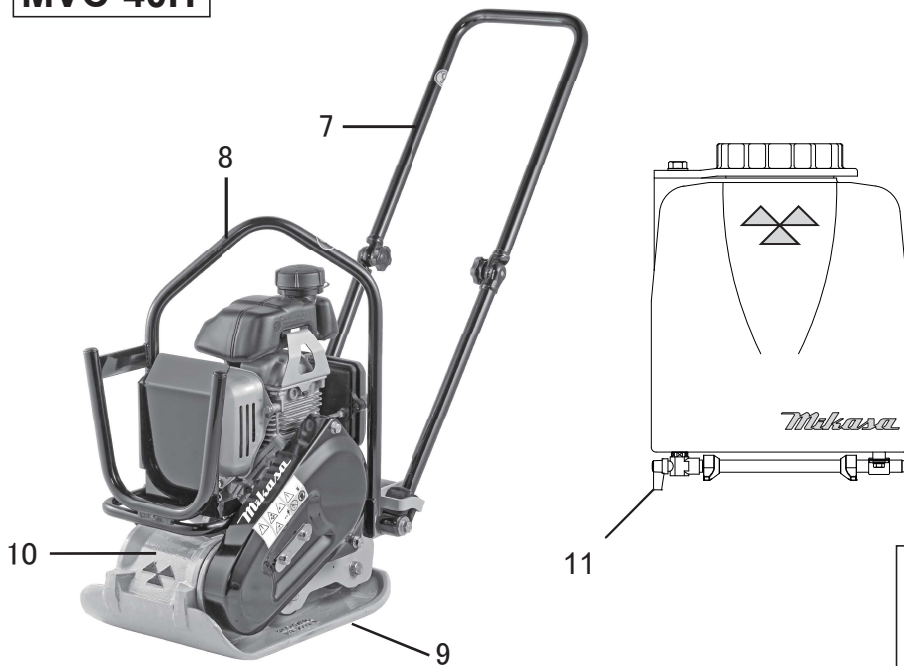

Honda GX100 ENGINE

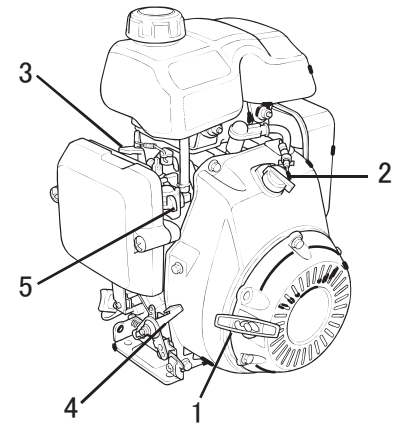

1. Starter Grip
2. Engine ON/OFF Switch
3. Choke Lever
4. Speed Control Lever
5. Fuel Cock
6. Handle Bar
7. Folding Handle
8. Lifting Hook
9. Vibrating Plate
10. Vibration Case
11. Water Shut-Off Valve

MVC-50H

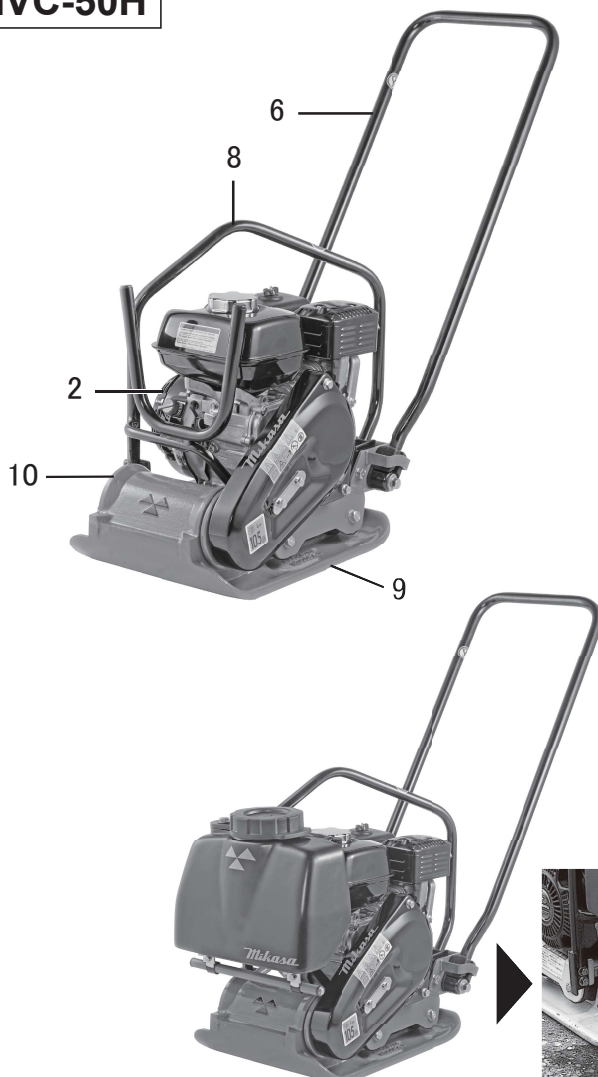

Honda GX120 ENGINE

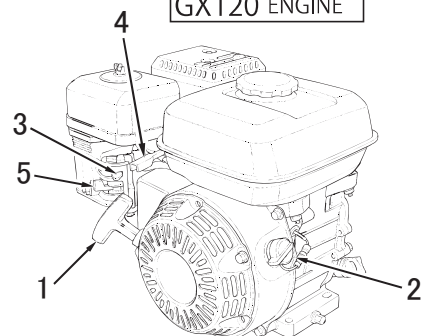

MVC-T90H / T100D

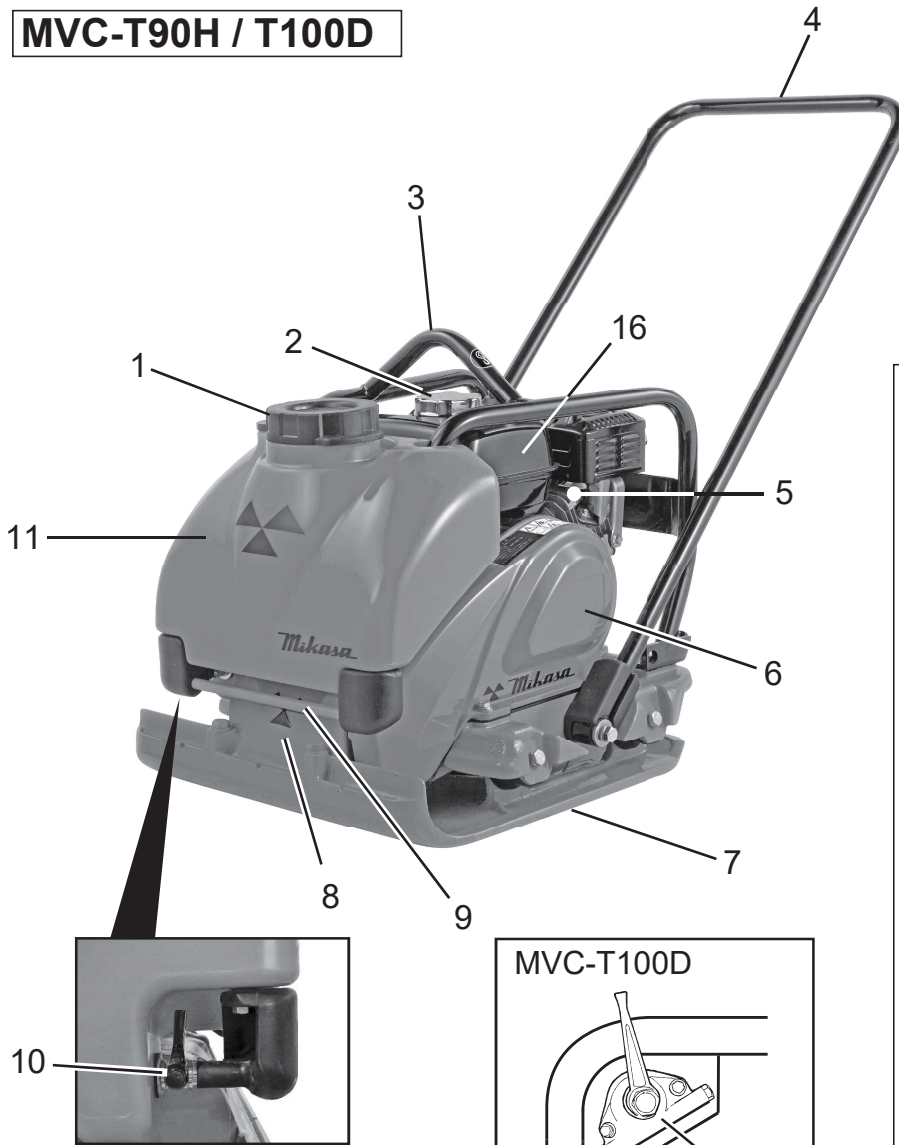

- 1. Water Tank Cap
- 2. Fuel Tank Cap
- 3. Lifting Hook
- 4. Handle Bar
- 5. Gasoline Engine
- 6. Belt Cover
- 7. Vibrating Plate
- 8. Vibration Case
- 9. Water Tube (Sprinkler)
- 10. Water Shut-Off Valve
- 11. Water Tank
- 12. Fuel Tank
- 13. Engine ON/OFF Switch
- 14. Recoil Starter (pullrope)
- 15. Air Cleaner
- 16. Spark Plug
- 17. Muffler
- 18. Starter Grip
- 19. Throttle Lever
- 20. Fuel Valve Lever
- 21. Choke Lever
- 22. Decompression Lever

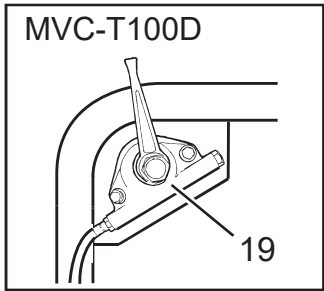
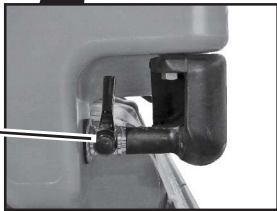

Honda
GX160 ENGINE

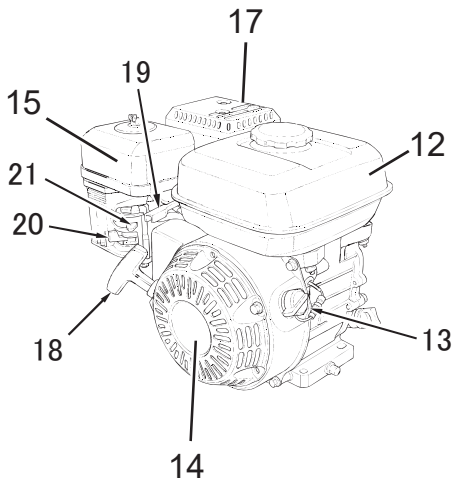

YANMAR
L48N ENGINE

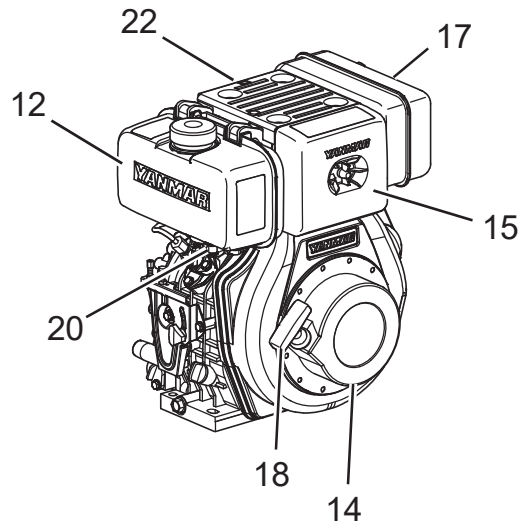

7. Inspection Before Operation

⚠ DANGER

Conduct inspection while the engine is stopped. If you get caught in the rotating parts, you may suffer serious damage. Conduct inspection after making this machine level and checking that the body does not move.

★ Refer to the "Regular Check and Adjustments" on page 17 for the inspection points before starting operation.

- 1 Clean each part of the machine well to maintain dirt and dust-free condition. Pay special attention to the soil adhered to the bottom of the vibrating plate, engine cooling air inlet, and the carburetor and air cleaner area to keep those parts clean.
- 2 Check each part for any looseness of bolts. Vibration causes bolts & nuts to loosen, which might result in unexpected accident or malfunction.
- 3 Inspect the guard hook, belt cover and anti-vibration rubber, as well as to check the function of speed adjustment wire and speed adjusting lever.
- 4 Check V-belt tension. The belt should have about 10 – 15mm of flexibility when pushed strongly with a finger at the mid-point between the axes. If V-belt is loosened, power is not transmitted well, which reduces compacting force and shortens the life of V-belt. In addition, the generated compaction force will lead to irregular vibrations when the engine revolutions are increased, and may result in a machine failure.
- 5 Set the engine on a level surface to check the oil level. If the oil level is low, add oil. Use the following engine oil.(Fig. 1)

Quality: Diesel engine oil, Grade CC or above
Gasoline engine oil, Grade SE or above
Viscosity: SAE No. 30 at 20°C and above (summer)
SAE10W-30

Temperature	Use oil
More than 25°C	SAE#30
10 ~ 25 °C	SAE#30, #20
10 ~ 0 °C	SAE#20
Less than 0 °C	SAE#10

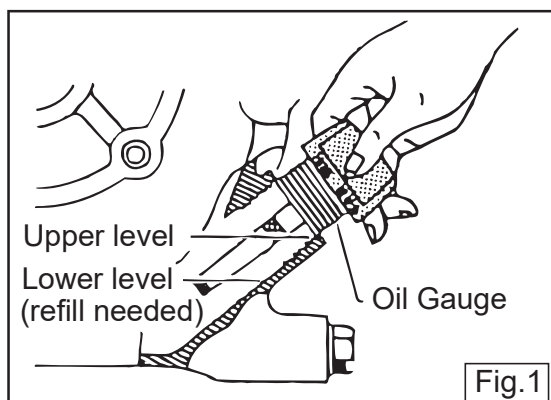

Fig.1

- 6 Set the machine on a level surface, then remove the oil gauge of the vibrator. Check the oil gauge to see if the oil is at the specified level. Use engine oil SAE10W-30 as lubrication oil.

Remove the oil plug in Vibrator Assembly and check the oil level. Make sure the oil quantity is set at level of plug hole for checking. Every month or every 200 hours of operation, replace the oil. (Fig.2)

Recommended oil quantity
MVC-40H/50H : 300cc
MVC-T90H/T100D : 200cc

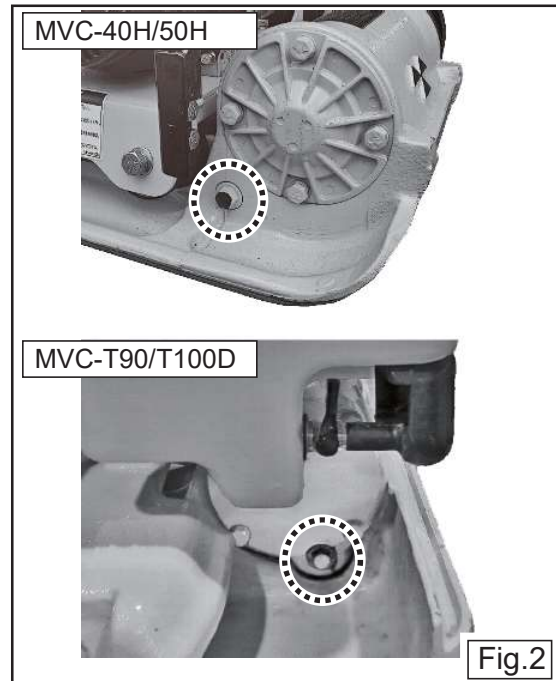

Fig.2

- 7 A regular grade gasoline or diesel oil should be used in the engine. When filling the fuel tank, make sure the fuel filter is used.

⚠ DANGER

- Never refuel this machine while leaving the engine running. There is danger of fire.
- Never smoke, or put other flames close to this machine while refueling. Serious hazards such as burns and fire may result.
- Choose a place free from flammable substances for refueling. Be careful not to spill fuel. In case fuel should be spilled, wipe off the spilled fuel completely.

- 8 Pour water into the water tank for sprinkling work.

Note: Pour water only. If you should put liquids other than water, the resin, tank cap seal, etc. may deteriorate or swell, leading to leakage or damage.

The water tank can be removed by pulling it upward. When mounting the water tank again, insert the hook into the groove of the water tank securely. The amount of sprinkling water can be adjusted by the cock.

How To Use Revolving Type Moving Cart (MVC-T90H,T100D)

For removal and reattachment of wheel, select a flat and hard surface area.

From Stopped Condition To Carrying Condition

- 1 Disengage the hook at the end of lock wire from the lock holder.
- 2 Pull up the lock knob to revolve the axle and let the wheel touch the ground. (Fig. 3)

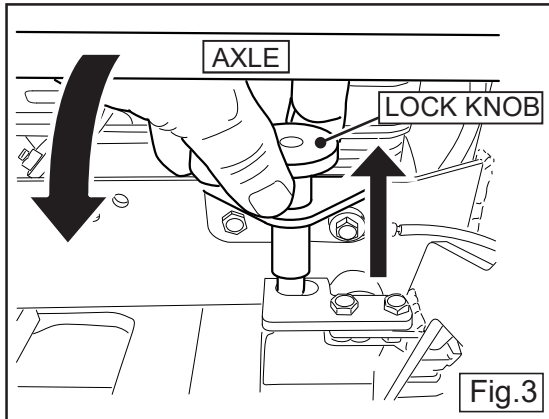

- 3 Put the lock wire around the handle, then let the end part hook on the wire. (Fig. 4)

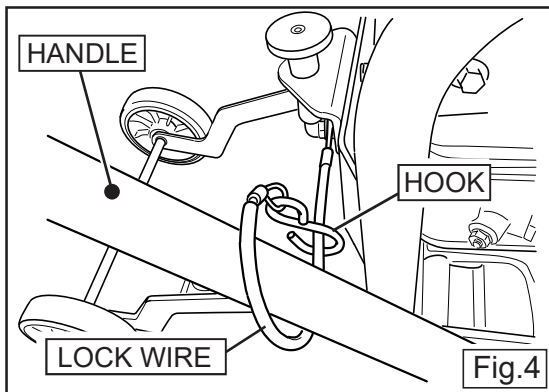

- 4 Tilt the handle to the front to let the rear end of the compaction board move up from the ground. Then, revolve the axle to below the compaction board until the axle arm touches the compaction board. (Fig. 5)

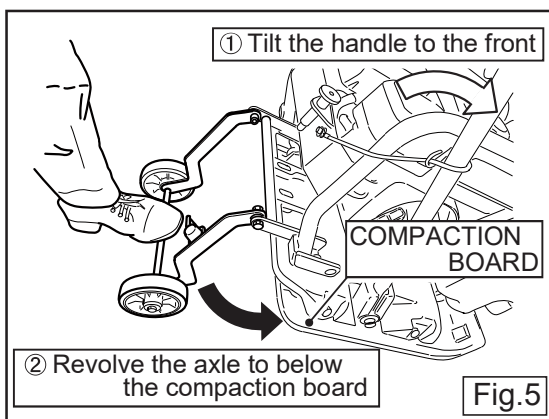

- 5 Pull back the handle to the rear, then raise the compaction board slightly from the ground to move the machine. (Fig. 6)

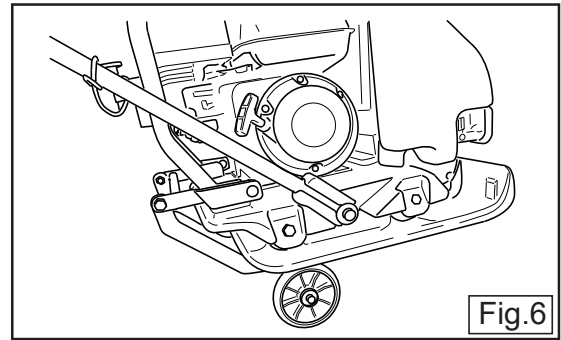

From Carrying Condition To Stopped Condition

- 1 Let the end of the compaction board touch the ground, then tilt the handle forward to make the wheel move away from the ground. (Fig. 7)

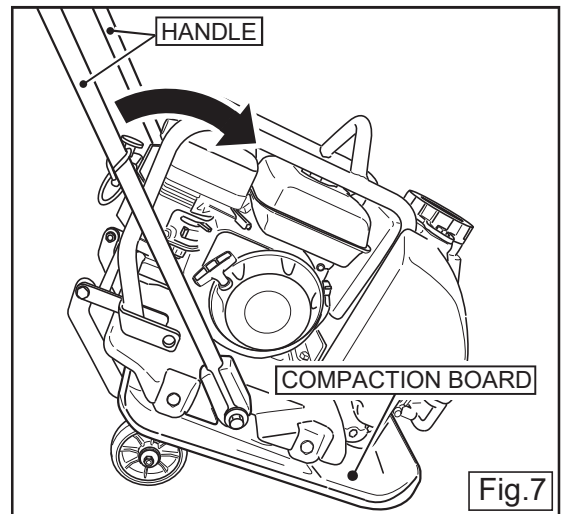

- 2 Turn the axle rearward, and let the compaction board touch the ground. (Fig. 8)

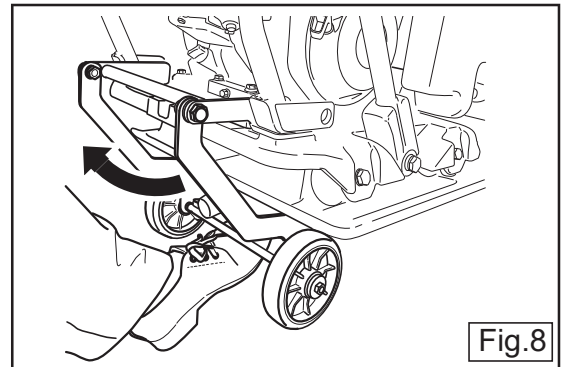

- 3 Raise the axle and revolve it to the stored position. (Fig. 9)

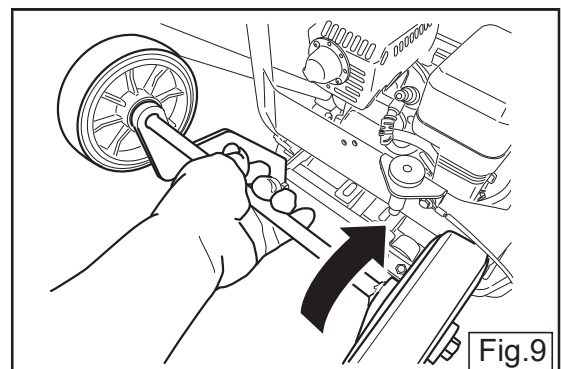

- 4 After the lock pin stopper touches the lock pin, the lock pin moves up, and once it fits into the stopper hole, it moves down automatically. Revolve until the lock pin is set to this locked condition. (Fig. 10)

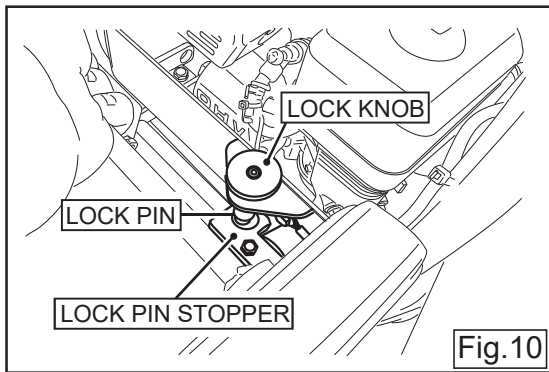

- 5 With the lock wire coming at the back side of the axle, put the hook at the end on the lock holder hole. (Fig. 11)

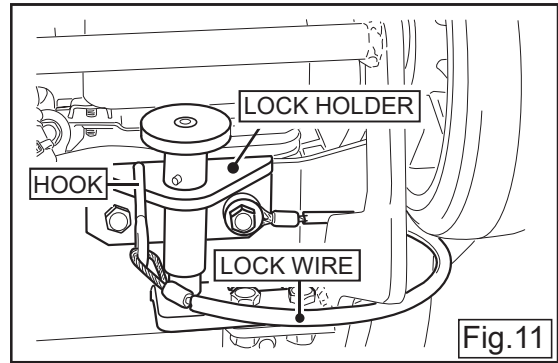

- 6 This completes the storing.

8. Operation

8.1 Starting



The engine exhaust gas contains carbon dioxide and is very dangerous. Do not use this machine where ventilation is poor.

Gasoline engine

- 1 Turn the lever of the fuel cock downward and feed fuel. (Fig.12-1 to 2)

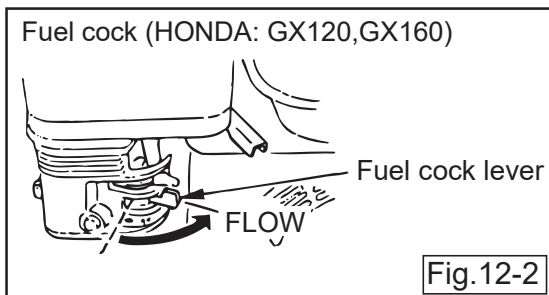
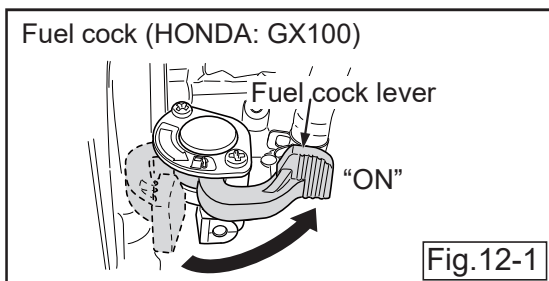

- 2 Turn the stop switch to "ON (I)" position. (Fig.13)

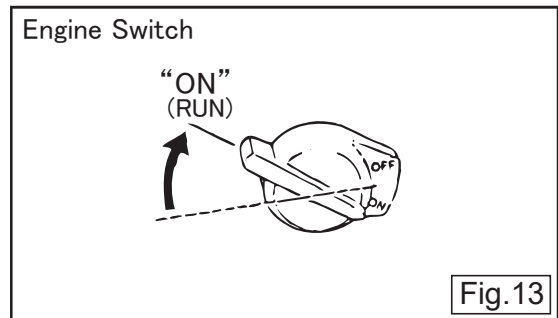

- 3 Open the speed control lever half. (Fig.14-1 to 2)

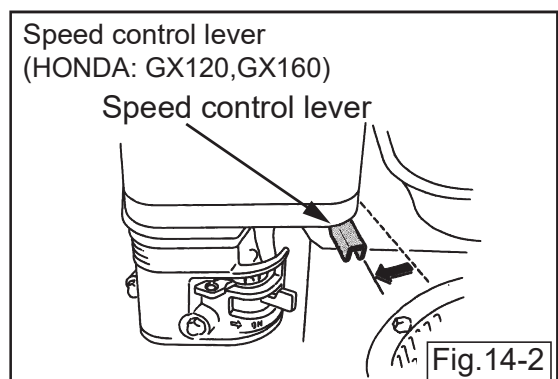
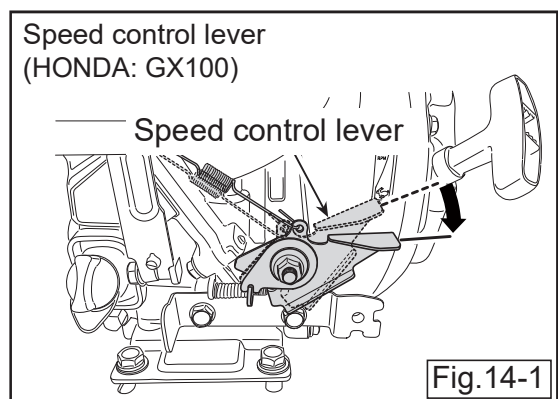

- 4 When it is cold or the engine does not start easily, close the choke lever. (Fig. 15-1 to 2)

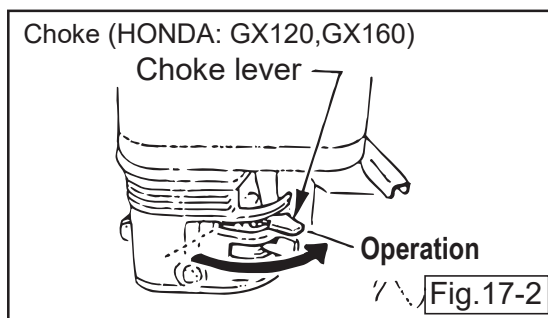
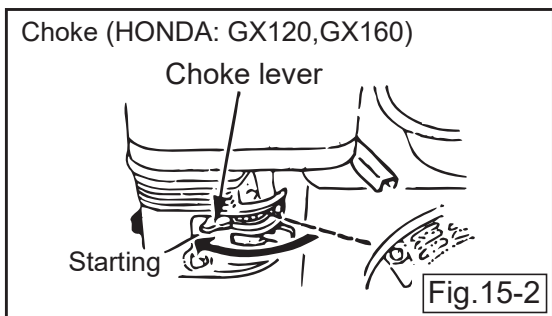
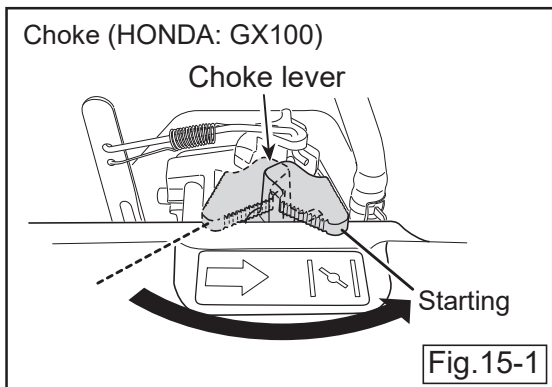

- 5 Grip the starting knob of the recoil starter. When you pull the rope a little, you will feel some resistance. Then pull it at a stroke. Be careful not to pull the rope too strongly, or the rope may break or come off. (Fig.16)

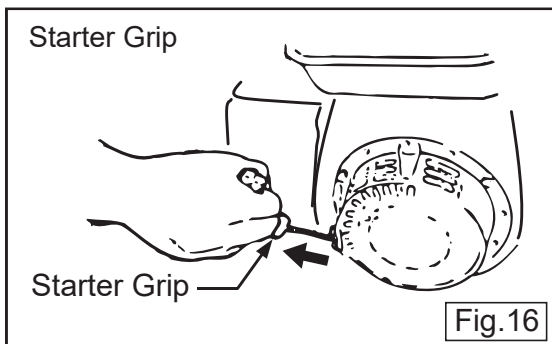

- 6 When the engine has started, return the speed control lever to the low speed position immediately. Listening to the sound of the explosion, return the choke lever gradually to the fully open condition. (Fig.17-1 to 2)

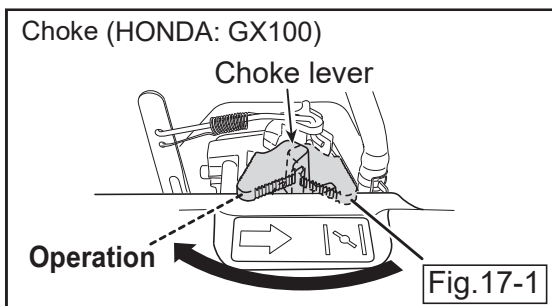

Diesel engine

- 1 Open the fuel cock lever. (Fig 18)

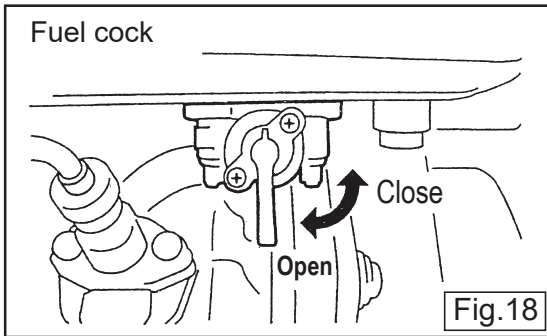

- 2 Open the speed control lever to about 30° for the idling position. (Fig.19)

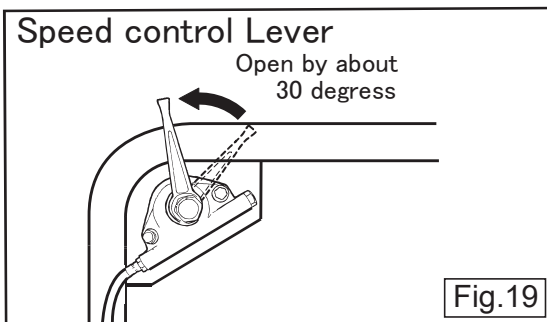

- 3 Push down the decompression lever and release. (Fig.20)

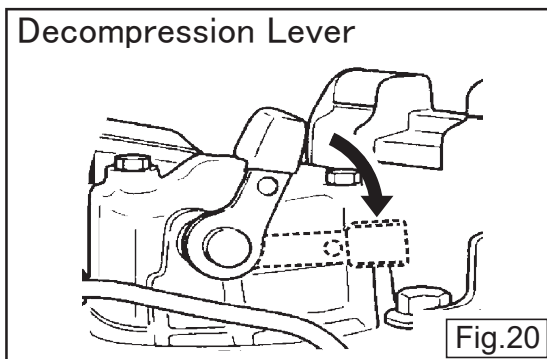

- 4 Grasp the starter grip and slowly pull it out. The resistance becomes the hardest at a certain position, corresponding to the compression point. Pull the starter grip briskly and smoothly for starting. (Fig.21)

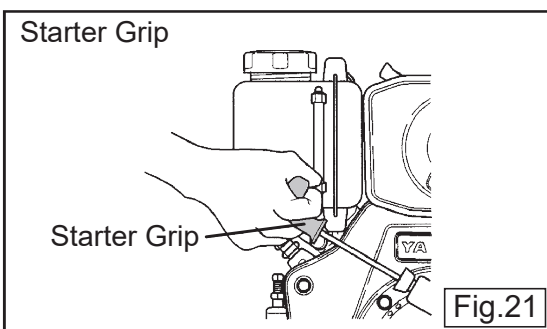

- 5 If the engine does not start, repeat steps 1 thru 4.

8.2 Operation

- 1 If you open the speed control lever at a stroke, this machine starts vibration and moves forward. If you open it slowly, the clutch may slip, so open the speed control lever at a stroke without hesitation. (Fig.22-1 to 3)

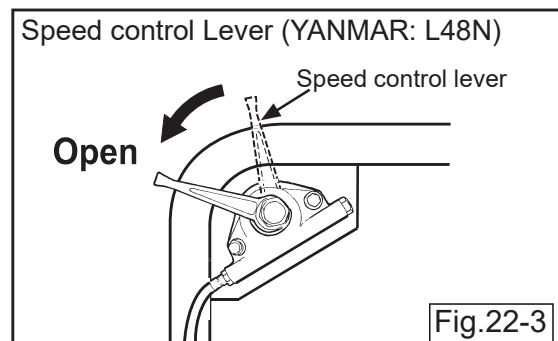
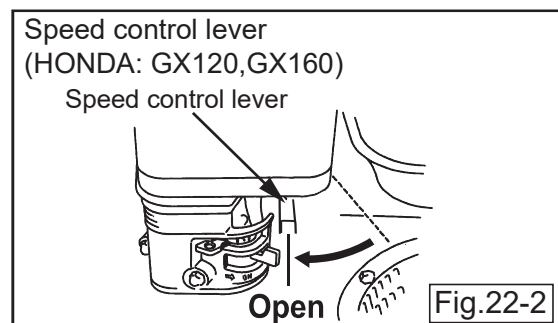
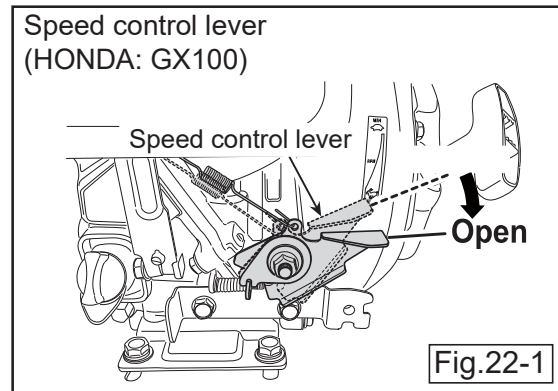

- 2 When this machine is used on cohesive soils, the vibrating plate dose not move over the ground easily and the travel speed becomes slow. Check that clay is not adhering to the bottom of the compaction board. The compaction force of this machine dose not act effectively on cohesive soils or soils of a high moisture ratio. In this case, use other machine such as a rammer, or dry the soils and decrease the moisture ratio.
- 3 When conducting sprinkling work, open the cock of the water tank.
- 4 When you stop the operation, return the speed control lever at a strake.

⚠ DANGER

- When you use machine on inclined area, various risk is accompanied. When you cannot get safety, never use it.
- Do not ride a weight on the machine. The machine loses the balance and there is fear a weight drops, and be damaged.
- If the machine is operated on the surface where one of the interlocking locks is too big or too heavy or when the road surface is sufficiently tamped, the vibration of the machine becomes big, causing the machine to get damaged earlier than normal. Also, the vibration that the operator's hands receive will increase, leading to a danger of vibration disease if the machine is operated for an extended period of time.

9. Stopping Machine

- 1 When you finish the work and stop the engine, return the speed control lever to the low speed position, and keep the engine running at low speed for 3-5minutes. When the temperature of the engine has decreased, stop the engine.

CAUTION

If you stop the engine while it is still hot, this machine will be affected adversely, causing, for example, burning of the oil film on the inner wall of the cylinder, which may accelerate wear of the inner wall of the cylinder. This may result in a shorter life of this machine, or cause unexpected failure.

Gasoline engine

- 2 Turn the engine switch to the OFF position, then the engine stops. (Fig. 23)

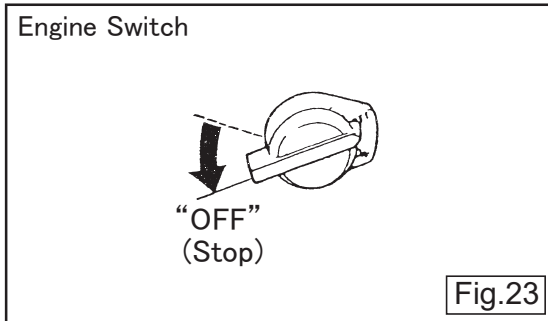

Diesel engine

- 2 Move the speed control lever to the stop position to stop the engine. (Fig. 24)

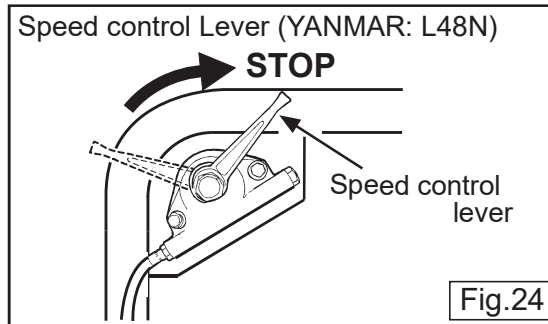

Common

- 3 Close the lever of the fuel cock. (Fig. 25-1 to 3)

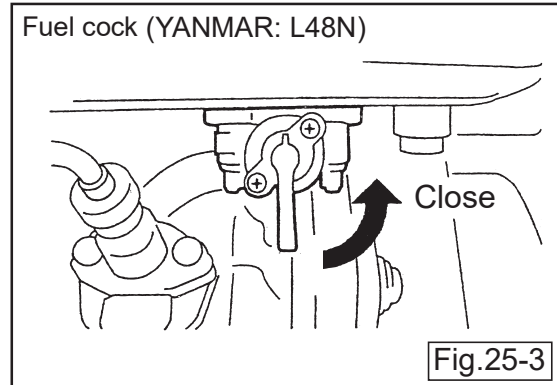
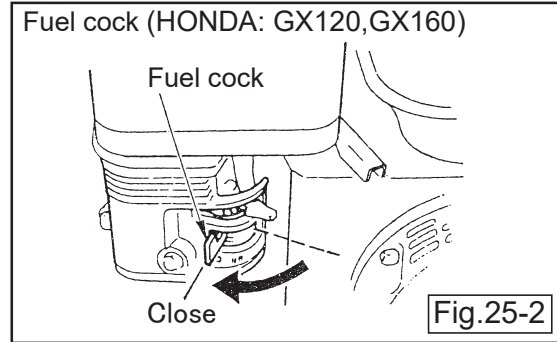
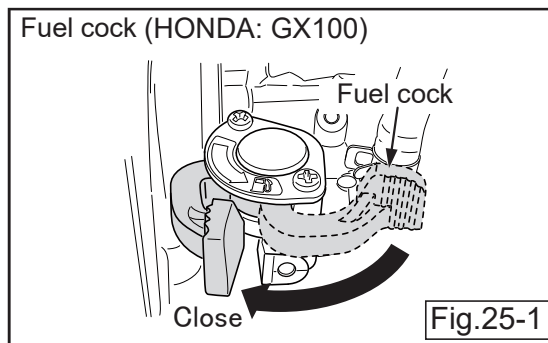

- 4 When you have conducted sprinkling work, close the cock of the water tank.

10 Transportation

⚠ WARNING

- Make sure there is no breakage of guard frame and anti-vibration rubber nor loosened or missing bolts.
- Always stop the engine when lifting.
- Use an intact wire rope without any deformation with sufficient strength.
- Slowly lift upward without applying any impact. Never let people or animals go under the lifted machine.
- For safety reasons, do not lift to a height that is higher than necessary.

10.1 Loading and Unloading

For loading and unloading using a crane, an operator qualified for cranes and hooking works is needed.

- 1 Use a crane for loading and unloading the machine.
- 2 Designate a person to guide the loading and unloading, and always work under the instruction of that person.
- 3 When lifting, always use a special hook on the guard frame. (Fig. 26)
Never lift by using the hook on the handle.

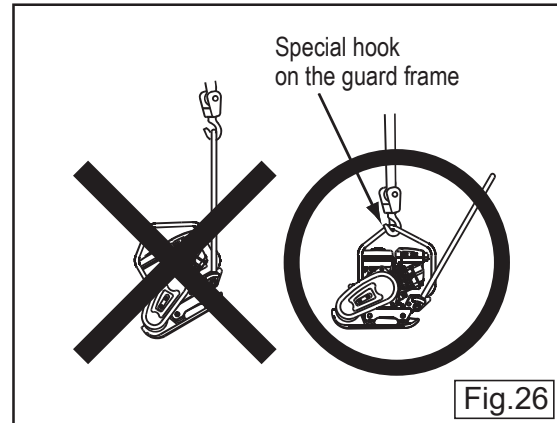

10.2 Transportation Precautions

⚠ WARNING

- Stop the engine when the machine is transported.
- Always drain the fuel before transportation.
- Fix the machine securely to prevent the machine from moving or falling.

11 Storage

- 1 Wash with water to remove any dust and dirt from all parts of the machine.
- 2 Store in a dry area away from direct sunlight after putting the cover over the machine to prevent dust and dirt buildup.
- 3 Drain the fuel from the fuel tank, fuel pipe, and carburetor completely.
- 4 Conduct fueling and replenishment/change of oil without omission. Remove the spark plug, put a few drops of engine oil into the cylinder, and rotate the engine manually for spreading the oil inside sufficiently.
- 5 Securely cover the air cleaner and muffler air inlets and exhaust port.
- 6 Do not leave the machine outdoors. Keep it indoors.
- 7 Do not store this machine by laying it on its side (or backward).

12. Regular Check and Adjustments

12.1 Inspection and Maintenance Schedule Table

Check frequency	Check parts	Check items	Oils
Daily (before starting)	Appearance	Flaw, deformation	
	Fuel tank	Leakage	
	Fuel system	Leakage	
	Engine oil	Leakage, oil level, dirt	Engine oil
	Shock absorber	Crack, damage, wear	
	Vibrator oil	Leakage	Engine oil
	Air cleaner element	Dust, deformation	
	Guard frame	Breakage, flaw, loosened or missing bolts and nuts	
	Bolts and nuts	Looseness, missing	
Every 20 hours	Engine oil	Replace only after the first 20 hours	Engine oil
	Engine oil filter (Diesel)	Replace only after the first 20 hours	
Every 100 hours	Engine oil	Change	Engine oil
	Engine oil filter	Washing	
	Vibrator oil	Leakage, oil level, dirt	Engine oil
Every 200 hours	V-belt for vibrator	Flaw, tension	
	Clutch	Dirt, flaw, wear	
	Engine bolt	Wear, deformation, degradation	
Every 300 hours	Vibrator oil	Change	Engine oil
	Fuel filter	Change	
	Engine oil filter (Diesel)	Change	
Every 2 years	Fuel pipes	Change	
As necessary in time	Air cleaner element	Change	

For details about the check and maintenance of the engine, please refer to the attached engine operation manual.

Caution:

The above table shows the check frequency for standard condition.

The check frequency may vary depending on the condition in which the machine is used.

For check of bolt and nut looseness and tightening, please see the following tightening torque list.

Tightening Torque List (unit: kgf-cm, 1kgf-cm=9.80665N-cm)

		Thread diameter							
		6mm	8mm	10mm	12mm	14mm	16mm	18mm	20mm
Material	4T(SS41)	70	150	300	500	750	1,100	1,400	2,000
	6-8T(S45C)	100	250	500	800	1,300	2,000	2,700	3,800
	11T(SCM3)	150	400	800	1,200	2,000	2,900	4,200	5,600
	When the mating material is aluminum.	100	300~350	650~700	(Bolts used on the machine are all right-hand thread.)				

12.2 Changing Engine Oil

Perform the first engine oil change after 20 hours of operation, then change at every 100 hours.

12.3 Cleaning Air Cleaner

When the air cleaner element becomes dirty, the engine does not start smoothly, and sufficient output cannot be obtained. Machine operation will be affected and the engine life will be shortened greatly. Do not forget to clean the element. (For details, please see the separate engine operation manual.) If the element cannot be cleaned, replace it with a new one.

12.4 Checking/Changing V-belt and Clutch

1 Checking V-belt

Remove the belt cover and check that V-belt is properly stretched every 200 hours. Press on the portion midway between the two shafts with your fingers strongly. The belt is properly stretched if that portion bows by about 10-15 mm.

2 Checking the clutch

Inspect Clutch concurrently with the inspection of V-belt. Check visually for burning of each clutch-shoe. Check for wear the lining shoe or the like, in the operation check. If the shoe wears, power transmission is not performed properly and Clutch slips. Check wear or any damage to V-groove also. If V-groove is stained, clean it thoroughly.

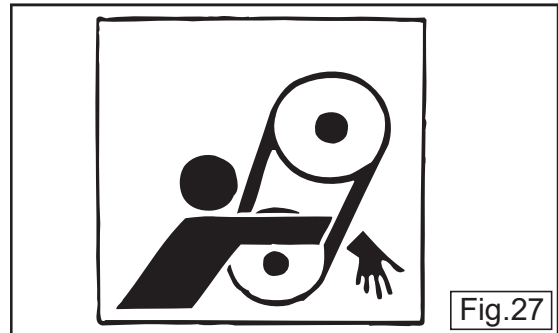

CAUTION

When the vibration weakens during operation, or this machine does not vibrate at all though the engine rotates normally, conduct the inspection or change of the V-belt and clutch without regard to the regular inspection of every 200 hours.

12.5 Inspection and Change of Vibrator Oil

Make this machine level, and remove the oil level plug off the vibrator. Check that vibrator oil is provided up to the mouth level. The oil level plug is on the right side of the vibrator case (opposite to the belt side). (Refer to Fig.1 on page 10.)

Use the engine oil #10W-30 for vibrator oil. Refer to page 10 for the amount. Drain the vibrator oil completely by removing the plug and tilting the body once a month or every 200 hours' operation. Replace with new oil.

CAUTION

Always stop the engine before inspection and adjustment. If you are caught in a rotating part, serious injury might occur.

13. Troubleshooting

1. Gasoline Engine

(1) Starting problem

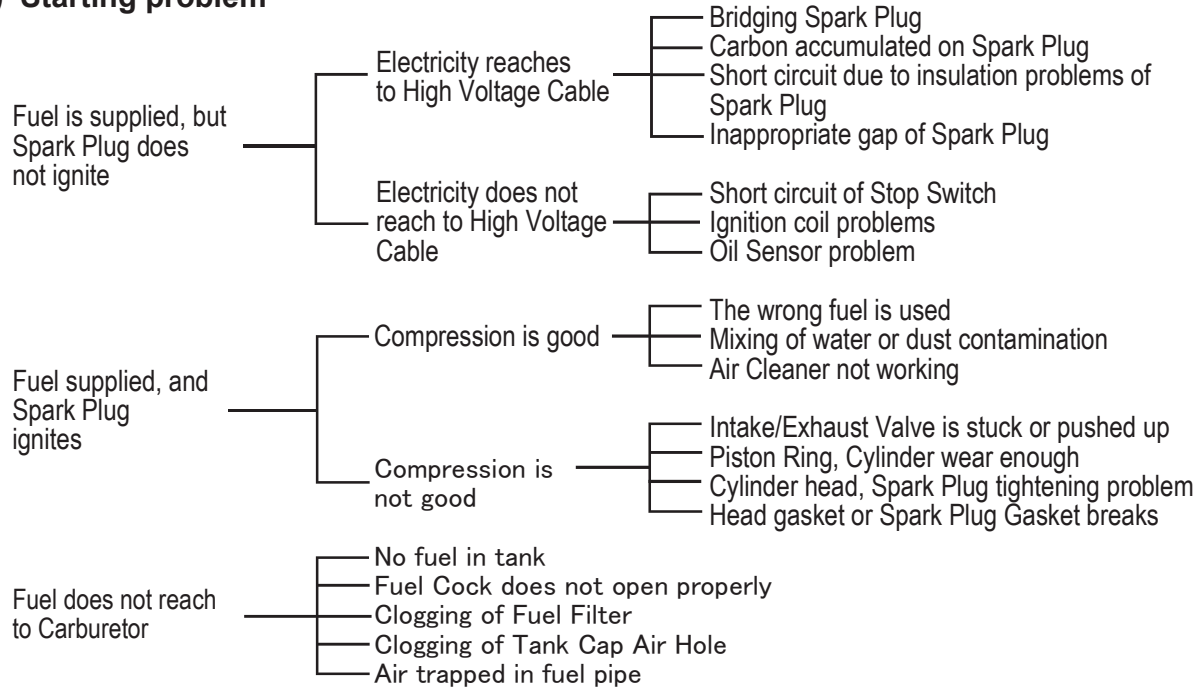

(2) Operation problem

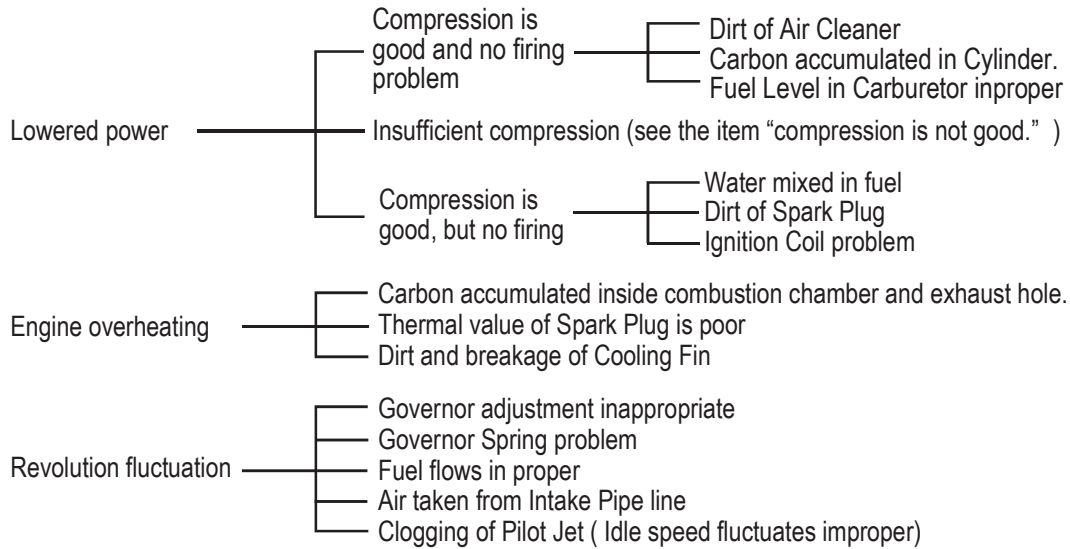

2. Main Body

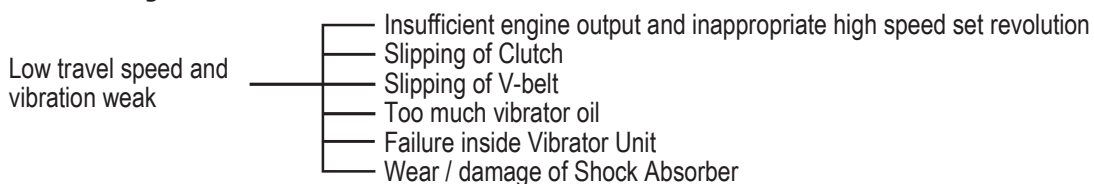

2. Diesel Engine

(1) Starting problem

(A) In case of compression problems

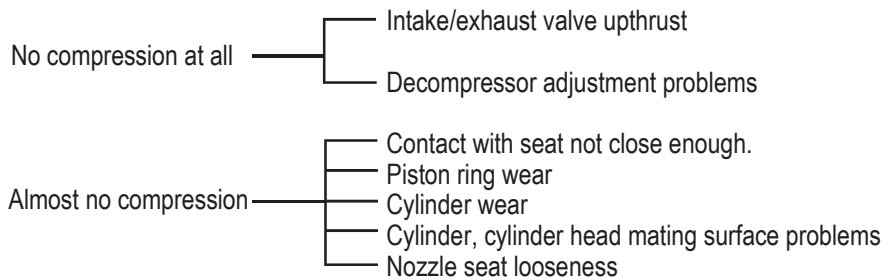

(B) In case of inappropriate fuel injection inside the combustion chamber

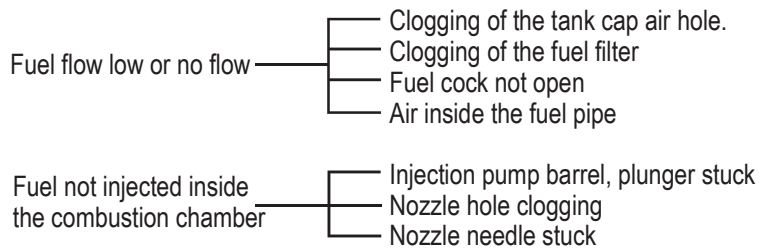

No fuel in the fuel tank

Mixing of water or foreign materials

(C) Fuel and compression pressure appropriate, but the engine does not start.

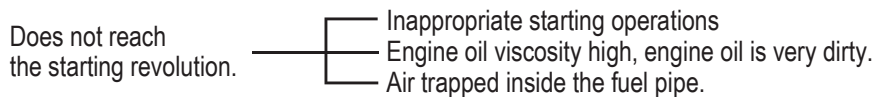

(2) Operation problem

Insufficient compression ————— See the comment for insufficient compression.

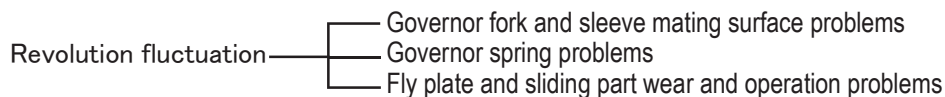
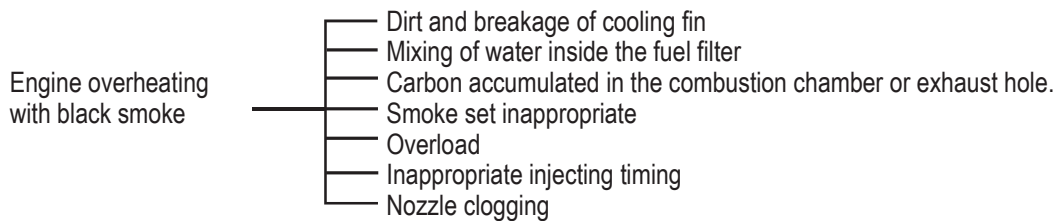

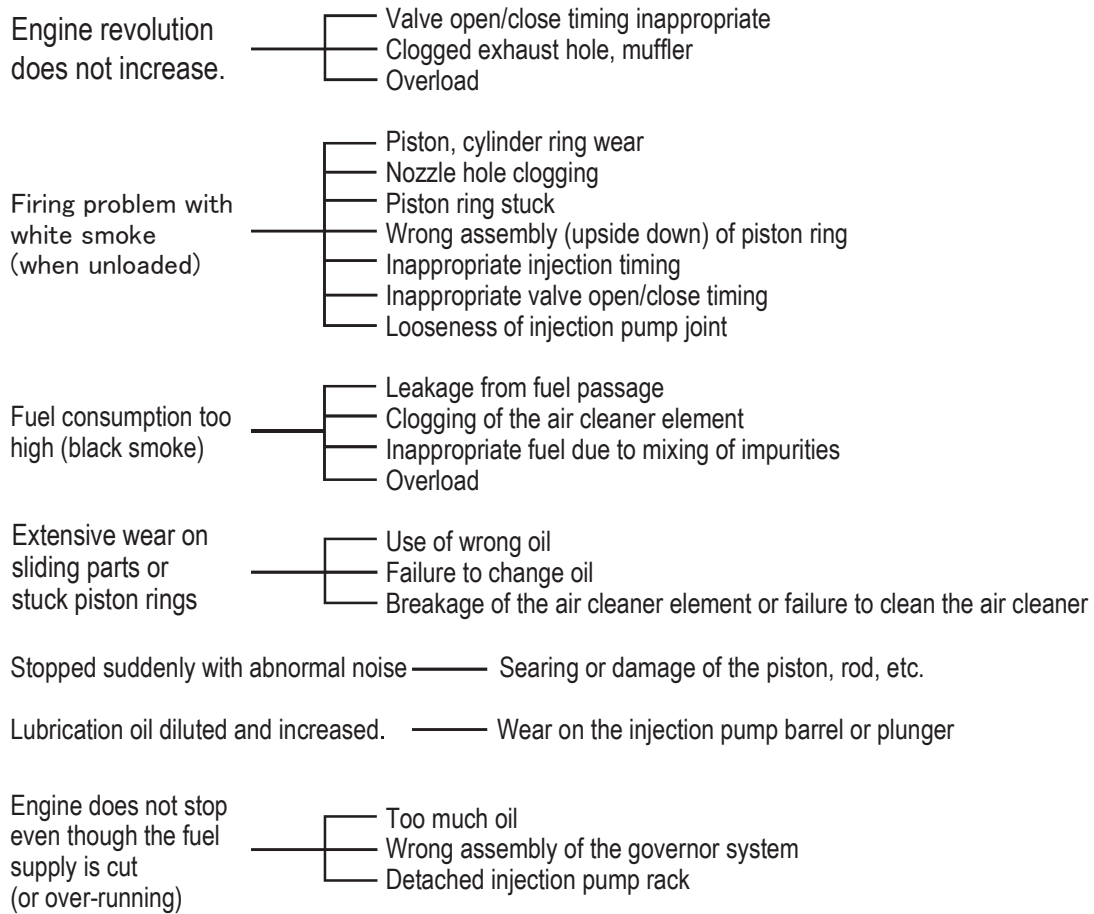

3. Main Body

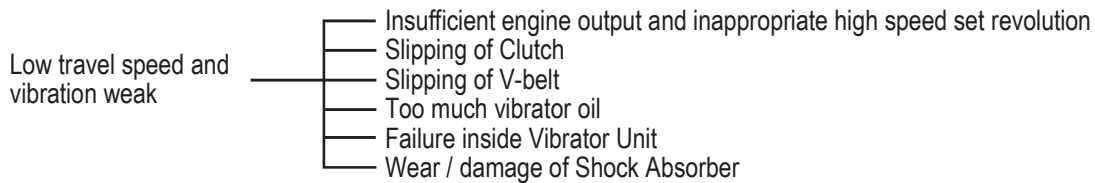

Mikasa