

Mikasa

REVERSIBLE COMPACTOR

MVH-208

MVH-209

MVH-308

MVH-408

MVH-508

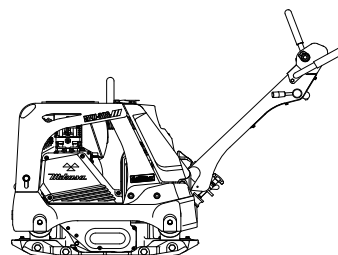

OPERATION MANUAL

en



<http://www.mikosas.com>

402-07418



EC Declaration of Conformity

1 Manufacturer's name and address	Mikasa Sangyo Co., Ltd. 1-4-3, Kanda-Sarugakucho, Chiyoda-ku, Tokyo, 101-0064, Japan	
2 Description of the equipment	Compaction machines (Vibratory Plates : Reversible Compactors) MVH-408DSZ — 107 108 Air cooled , 4 stroke CI engine (Hatz 1B50) : 6.7 kW	
2.1 Product		
2.2 Type		
2.3 Version(s)		
2.4 Measured sound power level dB(A)		
2.5 Guaranteed sound power level dB(A)		
2.6 Motor type : Net power		
3 Conformity assessment procedure	Annex VIII of 2000/14/EC as last amended by 2005/88/EC	
4 Notified Body's name and address	TÜV Rheinland LGA Products GmbH Tillystraße 2, 90431, Nürnberg, Germany Notified Body number: NB 0197	
5 Comply with relevant provisions and requirements of the following directives and standards	2000/14/EC , 2006/42/EC , 2014/30/EU EN 500-1:2006 +A1:2009 , EN 500-4:2011	
6 Signature	 _____	2nd Jun. 2022
	Keiichi Yoshida : Director, General Manager R&D Division	
7 Technical documentation keeper	Engineer , R&D Division , Mikasa Sangyo Co., Ltd. 15-1,Shimoosaki,Shiraoka-city,Saitama,349-0203,Japan	
Reference data	MVH-408DSZ	
Hand-arm vibration level ※ Ahv m/s ²	4.7	

※ Directive 2002/44/EC compliant. Test course (crushed gravel) is in comply with EN 500-4

EC Declaration of Conformity

1 Manufacturer's name and address	Mikasa Sangyo Co., Ltd. 1-4-3, Kanda-Sarugakucho, Chiyoda-ku, Tokyo, 101-0064, Japan	
2 Description of the equipment	Compaction machines (Vibratory Plates : Reversible Compactors) MVH-508DSZ — 108 109 Air cooled , 4 stroke CI engine (Hatz 1B81) : 8.9 kW	
2.1 Product		
2.2 Type		
2.3 Version(s)		
2.4 Measured sound power level dB(A)		
2.5 Guaranteed sound power level dB(A)		
2.6 Motor type : Net power		
3 Conformity assessment procedure	Annex VIII of 2000/14/EC as last amended by 2005/88/EC	
4 Notified Body's name and address	TÜV Rheinland LGA Products GmbH Tillystraße 2, 90431, Nürnberg, Germany Notified Body number: NB 0197	
5 Comply with relevant provisions and requirements of the following directives and standards	2000/14/EC , 2006/42/EC , 2014/30/EU EN 500-1:2006 +A1:2009 , EN 500-4:2011	
6 Signature	 <hr style="width: 20%; margin: auto;"/>	2nd Jun. 2022
	Keiichi Yoshida : Director, General Manager R&D Division	
7 Technical documentation keeper	Engineer , R&D Division , Mikasa Sangyo Co., Ltd. 15-1,Shimoosaki,Shiraoka-city,Saitama,349-0203,Japan	
Reference data	MVH-508DSZ	
Hand-arm vibration level ※ Ahv m/s ²	5.5	

※ Directive 2002/44/EC compliant. Test course (crushed gravel) is in comply with EN 500-4

EC Declaration of Conformity

1 Manufacturer's name and address	Mikasa Sangyo Co., Ltd. 1-4-3, Kanda-Sarugakucho, Chiyoda-ku, Tokyo, 101-0064, Japan		
2 Description of the equipment	Compaction machines (Vibratory Plates : Reversible Compactors) <div style="display: flex; justify-content: space-around;"> MVH-508GH MVH-408GH </div> <div style="display: flex; justify-content: space-around; margin-top: 10px;"> 107 108 </div> Air cooled , 4 stroke SI engine (Honda GX390) : 8.7 kW		
2.1 Product			
2.2 Type			
2.3 Version(s)			
2.4 Measured sound power level dB(A)			
2.5 Guaranteed sound power level dB(A)			
2.6 Motor type : Net power			
3 Conformity assessment procedure	Annex VIII of 2000/14/EC as last amended by 2005/88/EC		
4 Notified Body's name and address	TÜV Rheinland LGA Products GmbH Tillystraße 2, 90431, Nürnberg, Germany Notified Body number: NB 0197		
5 Comply with relevant provisions and requirements of the following directives and standards	2000/14/EC , 2006/42/EC , 2014/30/EU EN 500-1:2006 +A1:2009 , EN 500-4:2011		
6 Signature	 <hr style="width: 20%; margin: 0 auto;"/>		2nd Jun. 2022
	Keiichi Yoshida : Director, General Manager R&D Division		
7 Technical documentation keeper	Engineer , R&D Division , Mikasa Sangyo Co., Ltd. 15-1,Shimoosaki,Shiraoka-city,Saitama,349-0203,Japan		
Reference data	MVH-408GH	MVH-508GH	
Hand-arm vibration level ※ Ahv m/s ²	3.7	3.6	

※ Directive 2002/44/EC compliant. Test course (crushed gravel) is in comply with EN 500-4

TABLE OF CONTENTS

1. INTRODUCTION.....	1
2. MACHINE OVERVIEW.....	1
3. WARNING SIGNS.....	2
4. CAUTIONS FOR SAFETY.....	2
4.1 General Cautions	2
4.2 Refueling Precautions	3
4.3 Location And Ventilation Precautions	3
4.4 Precautions Before Starting	3
4.5 Precautions During Work	3
4.6 Lifting Precautions	3
4.7 Transportation And Storage Precautions	4
4.8 Maintenance Precautions	4
4.9 Label Position	5
4.10 Descriptions Of Symbols Used On Warning Labels	7
4.11 Control Unit Positions And Names	8
5. SPECIFICATION.....	9
6. APPEARANCE.....	11
7. INSPECTION BEFORE OPERATION.....	12
7.1 Engine Oil	12
7.2 Vibrator Oil	12
7.3 Refueling	13
7.4 Handle	13
8. OPERATION.....	14
8.1 Starting	14
8.2 Operation	18
8.3 Compaction Sensor (Compas II)	18
9. STOPPING THE MACHINE.....	20
10. TRANSPORTAION AND STORAGE.....	21
10.1 Loading And Unloading	21
10.2 Transportation Precautions	21
10.3 Storage	21
11. REGULAR CHECK AND ADJUSTMENT.....	22
11.1 Inspection And Maintenance Schedule Table	22
11.2 Open The Front Cover	23
11.3 Change The Engine Oil	23
11.4 Clean The Air Cleaner	24
11.5 Check/Change The V-belt	24
11.6 Check/Change The vibrator Oil	25
11.7 Check/Change The Hydraulic Oil	25
11.8 Battery	26
12. TROUBLESHOOTING.....	29
13. WIRING DIAGRAM.....	32

1. INTRODUCTION

- This operation manual describes the proper operation, basic inspection and maintenance procedures of the reversible compactor. Please read this operation manual before use in order to maximize the excellent performance of this machine and make your work more efficient and effective.
- After reading the manual, please keep it in a handy location for easy reference.
- For the handling the engine, please refer to the separate engine operation manual.
- For inquiries about repair parts, parts lists, service manuals, and repairs, please contact the store where you purchased the product, our sales office, or the Mikasa Parts Service Center. For parts lists, please visit our homepage at: <http://www.mikasas.com/> where you can access Mikasa WEB parts lists.

The illustrations in this manual might slightly differ in part from the machine you actually purchased due to design changes.

2. MACHINE OVERVIEW

Application

This machine is a compactor with back and forth motion. The strong vibration from the two-axes pendulum structure inside the vibrator changes the machine's motion into straight back and forth motion. The machine compacts through this motion. The machine has tightening and compacting effect for all ground types other than the soft soil with high water percentage. Because the machine is capable of straight back and forth movement, it works very effectively in grooved structures. Also, since the work efficiency of this machine is high, it is suitable for compacting of a large area. The machine also works well for flattening and leveling rough ground surface with irregularities created by the use of a powerful tamping rammer. The machine can be used widely for heavy compacting works such as base work as well as finishing work for asphalt paving.

Warning About Incorrect Applications And Techniques

Do not use this machine on ground with a high water percentage and, in particular, do not use on clay because the machine will not advance. Use this machine for compacting earth and sand mixtures, soil, sand or gravel. Do not use this machine for other type of work.

Structure

The upper part of the machine consists of an engine, handle, belt cover and exterior frame. The upper part of the machine is fixed to the vibrating plate of the lower part via an anti-vibration rubber. The lower part of this machine consists of a vibrating plate that incorporates a vibrator, there are two pendulums. The phase of those pendulums is changed by hydraulic pressure.

The hydraulic cylinder for the vibrator is connected with a hydraulic hose to the hydraulic pump, which is directly connected to the drive lever.

Power Transmission

Power is provided by an air-cooled single-cylinder 4-cycle gasoline engine or diesel engine. The engine output shaft is equipped with a centrifugal clutch. The centrifugal clutch is engaged when the engine speed increases. V-pulley is incorporated to the centrifugal clutch drum, and power is transmitted via the V-belt to the V-pulley on the vibrator side.

Through this process, the engine revolution is changed to the pendulum revolution suitable for compacting. The vibrator pulley rotates the pendulum axis of the drive side. The two pendulums inside the vibrator are fixed to the two pendulum axes that are positioned in parallel and are connected with the gear. The two axes rotate in opposite directions at the same speed to generate vibration.





There is a spiral groove on the inner periphery of the gear assembled on the pendulum axis to be driven. This groove serves as a key groove to let the guide pin slide to the axis direction. This guide pin is connecting the two pendulum axes. The phase of the two pendulums is changed by the axial sliding of the guide pin. The change in phase causes the vibration to change directions, thus changing the speed and travel direction of the machine.

Hydraulic pressure is used for the axial movement of the guide pin. At the end of the groove where the guide pin is attached, a piston is installed. When the oil level rises inside the hydraulic cylinder on the vibrator side and the pressure increases, the piston is pushed. Then the axis connected to the piston is pushed, which causes the guide pin attached to the axis to move, resulting in a change in phase.

The operator of the machine, by using the back and forth motion lever of the handle, can adjust the oil quantity and pressure by the connected hand pump to get the travel speed suitable for the work.

3. WARNING SIGNS

The triangle shaped  marks used in this manual and on the decals stuck on the main body indicate common hazards. Be sure to read and observe the cautions described.

 Warning labels indicating hazards to humans and to equipment.	
 DANGER	Denotes an extreme hazard. It calls attention to a procedure, practice, condition or the like, which, if not correctly performed or adhered to, is likely to result in serious injury or death.
 WARNING	Denotes a hazard. It calls attention to a procedure, practice, condition or the like, which, if not correctly performed or adhered to, could result in serious injury or death.
 CAUTION	Denotes a hazard. It calls attention to a procedure, practice, condition or the like, which, if not correctly performed or adhered to, could result in injury to people and may damage or destroy the product.
CAUTION (without at )	Failure to follow the instructions may result in damage to property.

4. CAUTIONS FOR SAFETY

4.1 General Cautions

WARNING

- Do not work with this machine, when
 - you are tired or sick and not feeling well,
 - you have taken medicine or drug, or
 - you have had a drink.



CAUTION

- Please read the operation manual well and work safely by using the machine properly.
- For handling of the engine, please refer to the separate engine operation manual.
- Please have a good understanding of the structure of this machine.
- Make sure to do work start inspection, regular self inspection and specified self inspection.
- To make your work safe, please use protective equipment (use specified helmet, protective shoes, etc.) and wear appropriate work clothes.
- Always use noise protection equipment such as ear muffs or ear plugs.
- Always check the machine to make sure it is in normal condition before operating the machine.
- The nameplates attached to the machine (nameplates showing operation method, warning, etc.) are very important for your safety. Clean the machine so that the nameplates can be read easily. If it is difficult to read the nameplate, please replace the old one with a new one.
- It is dangerous for young children to come near the machine. Please pay careful attention to the method of storing and the storage location for this machine. Especially the engine start key has to be taken out every time you finish your work, and keep it in a designated location.
- To do maintenance work, stop the engine and remove the battery wiring.
- We are not responsible for accidents that have occurred after the machine was refurbished without approval from the manufacturer.



4.2 Refueling Precautions

DANGER

- Always refuel in a well ventilated area.
- Make sure to stop the engine and wait until the engine cools down when refueling.
- Select a flat surface area with no flammable material around for refueling. Be careful not to spill the fuel. Wipe off well if there is any spill.
- Never put fire near the machine during refueling. (Especially, be careful about smoking.)
- If you fill to the top of the fuel tank inlet, fuel might spill out from the tank, and it becomes dangerous
- After refueling, tighten the tank cap well.

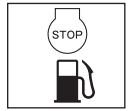

4.3 Location And Ventilation Precautions

DANGER

- Do not run the machine in an unventilated location, such as indoors or inside a tunnel. The exhaust gas from the engine contains toxic gases such as carbon monoxide and is very hazardous.
- Do not operate the machine near open flames.



4.4 Precautions Before Starting

CAUTION

- Check each part to see if it is tightened properly. Vibration causes loosening of bolts, which results in unexpected serious malfunctions of the machine. Tighten the bolts securely.

4.5 Precautions During Work

CAUTION

- Before starting the machine, make sure it is safe to start by checking your surroundings for people and objects.
- Always pay attention to your footing. Work in an area where you can maintain a good balance of the machine and a safe comfortable posture.
- The engine and muffler become very hot. Do not touch immediately after the machine stops because they are still very hot.
- If you notice deterioration of machine operation during your work, stop your work immediately.
- Before moving away from the machine, be sure to turn the engine off. Also when the machine is transported, stop the engine and close the fuel cock.
- For a machine with cell starter specification, do not operate without the battery. If you operate without the battery, electrical system failure might occur.



4.6 Lifting Precautions

DANGER

- Before lifting, check the machine parts (especially the hook and shock absorbers) for any damage and loosened or missing bolts.
- Stop the engine and shut the fuel cock while lifting.
- Use a sufficiently strong wire rope.
- For lifting, use only one point hoisting hook, and do not lift at any other part.
- When the machine is hoisted, never let people or animals come underneath.
- For safety reasons, do not lift to a height that is higher than necessary.



4.7 Transportation And Storage Precautions

WARNING

- Stop the engine during transportation.
- Transport after the engine and the machine are cooled down.
- Always drain the fuel before transporting.
- Securely fix the machine to prevent it from moving or falling during transportation.
- Do not store the machine on the place where it may be submerged.



4.8 Maintenance Precautions

WARNING

- Appropriate maintenance is required to ensure safe and efficient operation of the machine. Always pay attention to the machine's condition and keep it in good condition. Pay special attention to the parts used for lifting, if they are not maintained properly, it might result in a serious accident.
- Start maintenance work after the machine has cooled down completely. The muffler, in particular, becomes very hot, and there is a danger of burn. The engine, engine oil and vibrator also become very hot. Be careful not to get burned.



CAUTION

- Always stop the engine before inspection and adjustment. If you are caught in a rotating part, serious injury might occur.
- After maintenance work, check the security parts to see if they are securely installed. Special attention should be paid when checking bolts and nuts.
- If disassembly is involved in maintenance, refer to the maintenance instruction manual to make your work safe.



About The Battery

DANGER

- If the battery fixing bolts have been removed, put them back and tighten securely to fix the battery.
If used with the battery not fixed properly, contact with the battery terminal might occur, leading to electric shock and electric leak, or breakage of the battery might occur by the impact and vibration from outside, resulting in battery fluid leakage.
- The gas from the battery might cause an explosion. Do not generate sparks or bring flames near the battery.
- Never put the positive terminal and negative terminal come into contact. Sparks will be generated, and ignition might occur.

WARNING

- Be careful when handling the battery fluid because it is very toxic. If the battery fluid gets on your skin, eye, or clothes, rinse it off with plenty of water and consult with a doctor.

4.9 Label Position

※ The illustration is shown for model, "MVH-308"

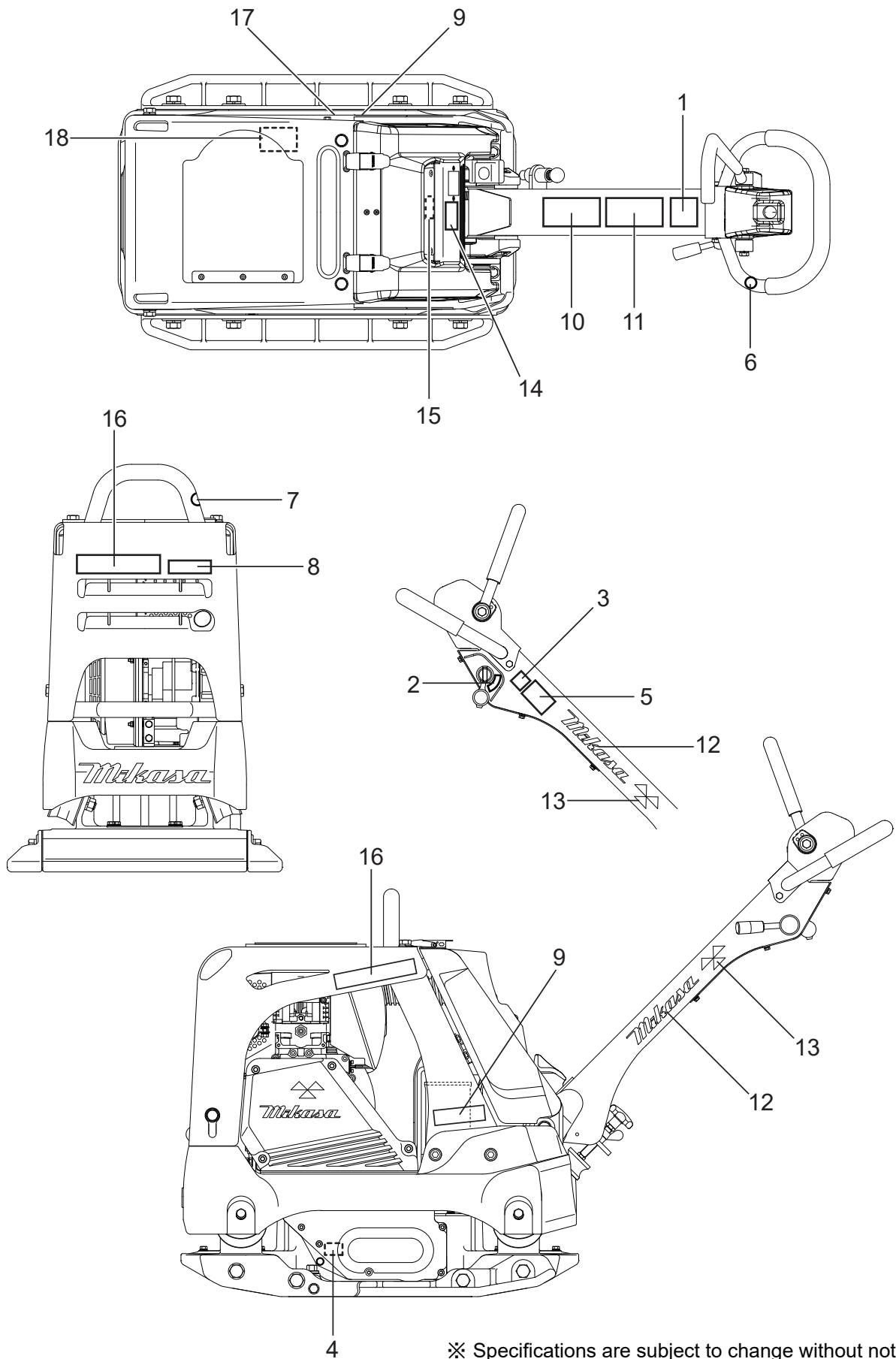







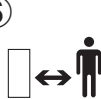

※ Specifications are subject to change without notice.

REF No.	PART No.	PART NAME	Q'TY	REMARK
1	9202-10100	DECAL,EC NOISE REQ.LWA108	1	308,408,508G
	9202-10670	DECAL,EC NOISE REQ.LWA109	1	508D
2	9201-08800	DECAL, KEY SWITCH	1	Diesel,508G
3	9202-14960	DECAL, KEY OPERATION	1	Diesel,508G
4	9202-01950	DECAL,OIL SAE 10W-30	1	
5	9202-14950	DECAL,REMOVE KEY	1	Diesel Only
6	9202-14730	DECAL,DO NOT LIFTING	1	
7	9202-14740	DEAL,LIFTING POSITION	1	
8	9202-17640	DECAL COMPASS MARK 94MM	1	308D,408D,508G
	9202-17650	DECAL COMPASS MARK 110MM	1	508D
9	9202-17650	DECAL COMPASS MARK 110MM	2	Diesel,508G
10	9202-14760	DEAL,CAUTION ICONS/V-TYPE	1	
11	9202-14750	DECAL,ENGINE HANDLING /GS	1	Petrol Only
12	9202-17130	DECAL,MIKASA MARK(W)200L	2	
13	9202-17110	DECAL, MIKASA MARK 35X70	2	
14	9202-18140	DECAL, E/G RPM 3400	1	208(209)G/D,308D
	9202-18130	DECAL, E/G RPM 3600	1	308 G,508G
	9202-18150	DECAL, E/G RPM 2400	1	408D,508D
	9202-18160	DECAL, E/G RPM 3200	1	208(209)DY,408 G
15	9202-17870	DECAL, MODEL MVH-308	1	308
	9202-17880	DECAL, MODEL MVH-408	1	408
	9202-17890	DECAL, MODEL MVH-508	1	508D
	9202-24620	DECAL, MODEL MVH-508GHS	1	508G
16	9202-20060	DECAL,MODEL MVH-208 R-GR	2	208
	9202-20080	DECAL,MODEL MVH-208 R-OR	2	208
	9202-20100	DECAL,MODEL MVH-209 R-GR	2	209
	9202-20120	DECAL,MODEL MVH-209 R-OR	2	209
	9202-17710	DECAL,MODEL MVH-308 R-GR	2	308
	9202-17730	DECAL,MODEL MVH-308 R-OR	2	308
	9202-17750	DECAL,MODEL MVH-408 R-GR	2	408
	9202-17770	DECAL,MODEL MVH-408 R-OR	2	408
	9202-17790	DECAL,MODEL MVH-508 R-GR	2	508
9202-17810	DECAL,MODEL MVH-508 R-OR	2	508	
17	9202-20070	DECAL,MODEL MVH-208 L-GR	1	208
	9202-20090	DECAL,MODEL MVH-208 L-OR	1	208
	9202-20110	DECAL,MODEL MVH-209 L-GR	1	209
	9202-20130	DECAL,MODEL MVH-209 L-OR	1	209
	9202-17720	DECAL,MODEL MVH-308 L-GR	1	308
	9202-17760	DECAL,MODEL MVH-308 L-OR	1	308
	9202-17740	DECAL,MODEL MVH-408 L-GR	1	408
	9202-17780	DECAL,MODEL MVH-408 L-OR	1	408
	9202-17800	DECAL,MODEL MVH-508 L-GR	1	508
9202-17820	DECAL,MODEL MVH-508 L-OR	1	508	
18	—————	PLATE,SERIAL NO.	1	Not For Sale

※ P/N: 9209-00110, DECAL SET includes REF No. 4-7 for the above.

4.10 Descriptions Of Symbols Used On Warning Labels

- | | |
|---|--|
| <p>①  Lethal Exhaust Gas Hazard.
Carbon monoxide poisoning may occur if the exhaust gas is inhaled. Do not operate the machine in a poorly ventilated area.</p> | <p>⑥  Keep safe distance.
Be careful not to approach danger source during operation.</p> |
| <p>②  Rotating Parts Hazard.
Keep hands clear from all moving parts (such as inside the belt cover) to prevent injury.</p> | <p>⑦  Fire hazard.
Keep away any flames and sparks from the machine.</p> |
| <p>③  Refueling Hazard.
Stop the engine and let cool before refueling.</p> | <p>⑧  Noise hazard.
Always wear ear protection while operating the machine.</p> |
| <p>④  Read the manual carefully.
Read and fully understand the operation manual before operating the machine.</p> | <p>⑨  No lifting position.
Do not use any other points (such as the handle) except one point lifting hook for lifting the machine.</p> |
| <p>⑤  Burn Hazard.
Never touch the hot parts. Allow these parts to cool before servicing the machine.</p> | <p>⑩  Lifting position.
Use one point lifting hook for lifting the machine.</p> |

Starting and stopping for gasoline engine

START

- ① Open Fuel Cock to start.
- ② Turn Stop Switch to "I"(ON) position.
- ③ Close Choke Lever.
- ④ Pull Recoil Starter to start the engine.
- ⑤ Return Choke Lever to open.

STOP

- ① Return Throttle Lever fully until "O"(OFF) position to stop work.
- ② After cooling down enough, turn Stop Switch to "O"(OFF) position to stop the engine.
- ③ Close Fuel Cock at the end.

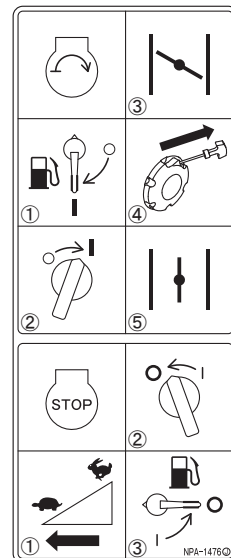

※ **Regarding Diesel engines, refer to those engine operation manuals.**

4.11 Control Unit Positions And Names

※ The illustration is shown for model, "MVH-308"

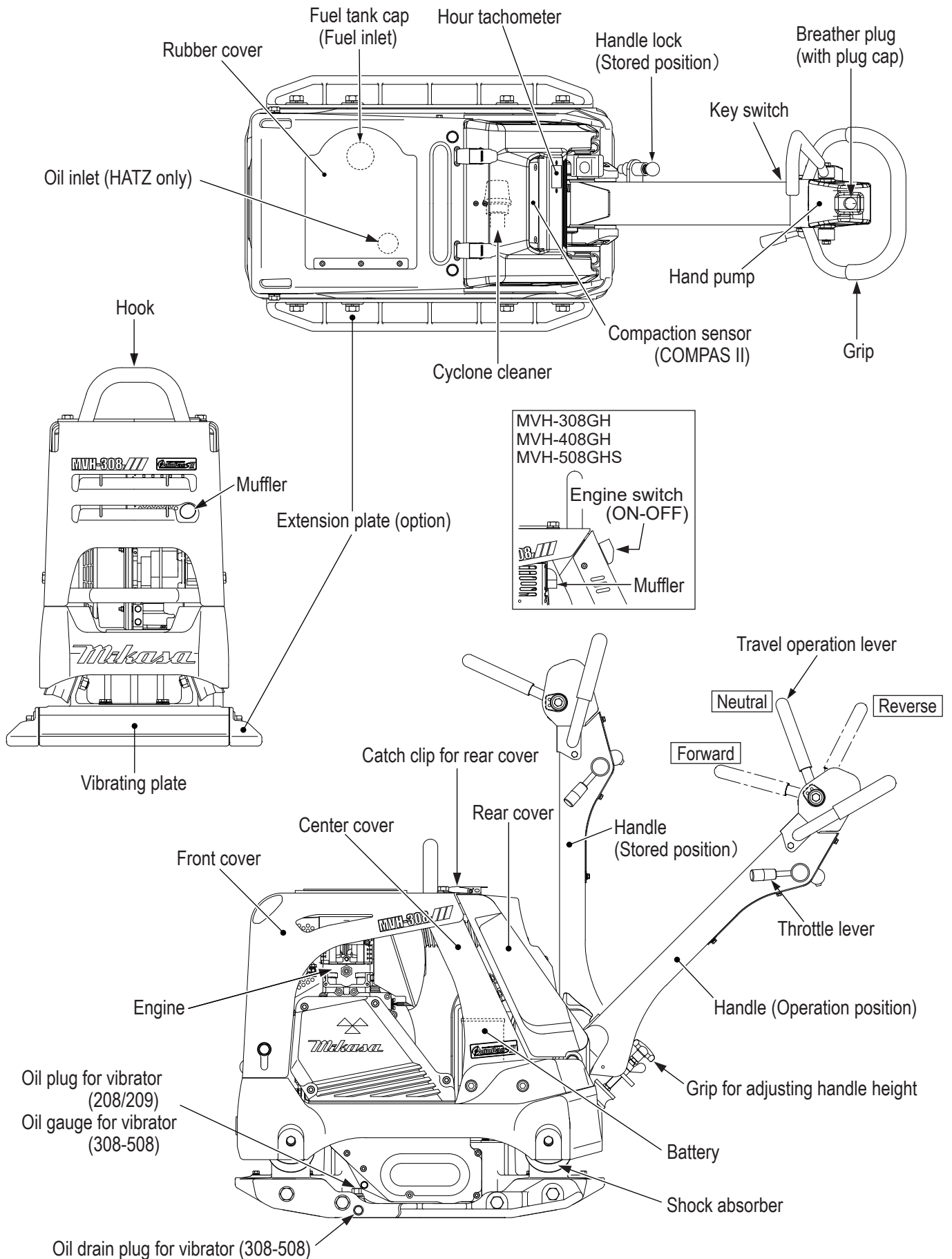

※ Specifications are subject to change without notice.

5. SPECIFICATIONS

MODEL		MVH-208DSZ	MVH-208DSY	MVH-209DSZ	MVH-308DSZ MVH-308DSZ-PAS
Main Dimensions					
Overall Length	mm	1310	1310	1310	1540
Overall Height (Handle)	mm	1010	1010	1010	1030
Overall Width	mm	500	500	600	445 (595, 745)
Vibrating Plate					
Width	mm	500	500	600	445 (595, 745)
Length	mm	720	720	720	860
Weight					
Operating Weight	kg	240	237	247	345 (360, 375)
Engine					
Manufacturer/Type		HATZ 1B30	YANMAR L70N	HATZ 1B30	HATZ 1B30
Type Of Engine		Air-cooled 4-cycle diesel engine	Air-cooled 4-cycle diesel engine	Air-cooled 4-cycle diesel engine	Air-cooled 4-cycle diesel engine
Maximum Power	kw/rpm PS/rpm	4.9/3300 6.7/3300	4.9/3600 6.7/3600	4.9/3300 6.7/3300	4.9/3300 6.7/3300
Operating Engine Speed	r.p.m	3350	3100	3350	3350
Electric Start		○	○	○	○
Performance					
Vibrating Frequency	Hz/VPM	87/5200	87/5200	87/5200	73/4400
Centrifugal Force	kN/kgf	37/3772	35/3570	37/3772	45/4600
Max. Traveling Speed	m/min	0~27	0~26	0~26	0~27
Hand Arm Vibration (Ahv)	m/sec ²	3.8	-	4.4	6.1

MODEL		MVH-308DSY MVH-308DSY-PAS	MVH-408DSZ MVH-408DSZ-PAS	MVH-408DSY MVH-408DSY-PAS	MVH-508DSZ MVH-508DSZ-PAS
Main Dimensions					
Overall Length	mm	1540	1570	1570	1600
Overall Height (Handle)	mm	1030	1030	1030	1070
Overall Width	mm	445 (595, 745)	500 (650, 800)	500 (650, 800)	650 (800)
Vibrating Plate					
Width	mm	445 (595, 745)	500 (650, 800)	500 (650, 800)	650 (800)
Length	mm	860	900	900	900
Weight					
Operating Weight	kg	341 (356, 371)	408 (423, 438)	407 (422, 437)	525 (540)
Engine					
Manufacturer/Type		YANMAR L70N	HATZ 1B50	YANMAR L100N	HATZ 1D81S
Type Of Engine		Air-cooled 4-cycle diesel engine	Air-cooled 4-cycle diesel engine	Air-cooled 4-cycle diesel engine	Air-cooled 4-cycle diesel engine
Maximum Power	kw/rpm PS/rpm	4.9/3600 6.7/3600	6.7/2500 9.1/2500	7.0/3200 9.5/3200	8.9/2500 12.1/2500
Operating Engine Speed	r.p.m	3600	2350	3200	2350
Electric Start		○	○	○	○
Performance					
Vibrating Frequency	Hz/VPM	73/4400	73/4400	73/4400	69/4150
Centrifugal Force	kN/kgf	45/4600	55/5600	50/5100	65/6600
Max. Traveling Speed	m/min	0~27	0~28	0~27	0~29
Hand Arm Vibration (Ahv)	m/sec ²	-	4.7	-	5.5

※ Specifications are subject to change without notice.

※ The number in parentheses is the dimensions with “extension plate (option)” .

“()” : MVH-308,408: (standard type, wide type)
MVH-508: (wide type)

MODEL		MVH-208GH	MVH-209GH	MVH-308GH	MVH-408GH
Main Dimensions					
Overall Length	mm	1310	1310	1540	1570
Overall Height (Handle)	mm	1010	1010	1030	1030
Overall Width	mm	500	600	445 (595, 745)	500 (650, 800)
Vibrating Plate					
Width	mm	500	600	445 (595, 745)	500 (650, 800)
Length	mm	720	720	860	900
Weight					
Operating Weight	kg	210	217	310 (325, 340)	364 (379, 394)
Engine					
Manufacturer/Type		HONDA GX270	HONDA GX270	HONDA GX270	HONDA GX390
Type Of Engine		Air-cooled 4-cycle petrol engine	Air-cooled 4-cycle petrol engine	Air-cooled 4-cycle petrol engine	Air-cooled 4-cycle petrol engine
Maximum Power	kw/rpm PS/rpm	6.3/3600 8.6/3600	6.3/3600 8.6/3600	6.3/3600 8.6/3600	8.7/3600 11.8/3600
Operating Engine Speed	r.p.m	3400	3400	3600	3200
Electric Start		×	×	×	×
Performance					
Vibrating Frequency	Hz/VPM	87/5200	87/5200	73/4400	73/4400
Centrifugal Force	kN/kgf	37/3772	37/3772	45/4600	55/5600
Max. Traveling Speed	m/min	0~27	0~26	0~27	0~28
Hand Arm Vibration (Ahv)	m/sec ²	4.0	3.7	2.8	3.7

MODEL		MVH-508GHS MVH-508GHS-PAS
Main Dimensions		
Overall Length	mm	1570
Overall Height (Handle)	mm	1030
Overall Width	mm	650 (800)
Compacting Board		
Width	mm	650 (800)
Length	mm	900
Weight		
Operating Weight	kg	425 (440)
Engine		
Manufacturer/Type		HONDA GX390
Type Of Engine		Air-cooled 4-cycle petrol engine
Maximum Power	kw/rpm PS/rpm	8.7/3600 11.8/3600
Operating Engine Speed	r.p.m	3600
Electric Start		○
Performance		
Vibrating Frequency	Hz/VPM	73/4400
Centrifugal Force	kN/kgf	60/6120
Max. Traveling Speed	m/min	0~29
Hand Arm Vibration (Ahv)	m/sec ²	3.6

Remarks:

Vibration Level is in comply with EU Directive 2002/44/EC and the value is shown as 3 axis min vibration level.

Test course (Crushed gravel) is in comply with EN500-4.

The above values are subject to change in case that the machine is modified or/and the required regulations change.

※ Specifications are subject to change without notice.

※ The number in parentheses is the dimensions with “extension plate (option)” .

“()” : MVH-308,408: (standard type, wide type)
MVH-508: (wide type)

6. APPEARANCE

MVH-208
MVH-209
MVH-308
MVH-408

※ The illustration is shown for model, "MVH-308".

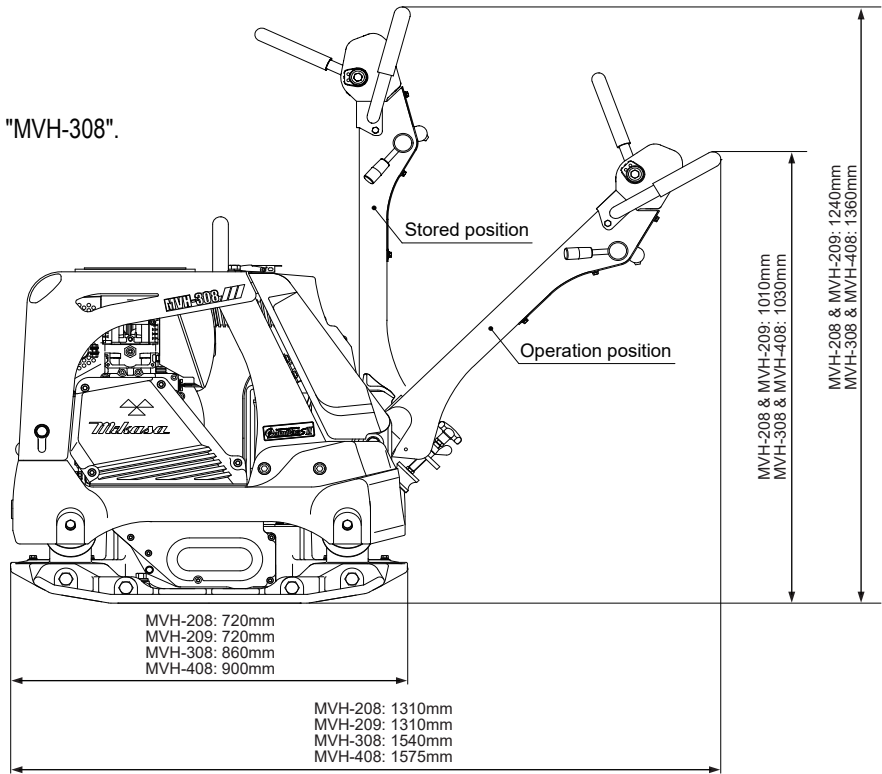
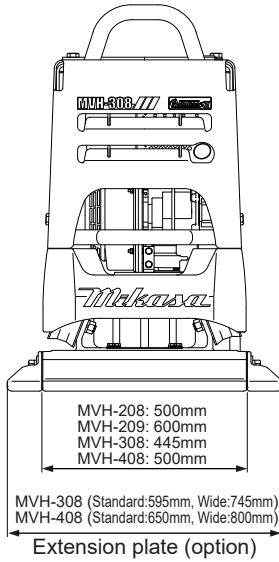

MVH-508

※ The illustration is shown for model, "MVH-508DSZ".

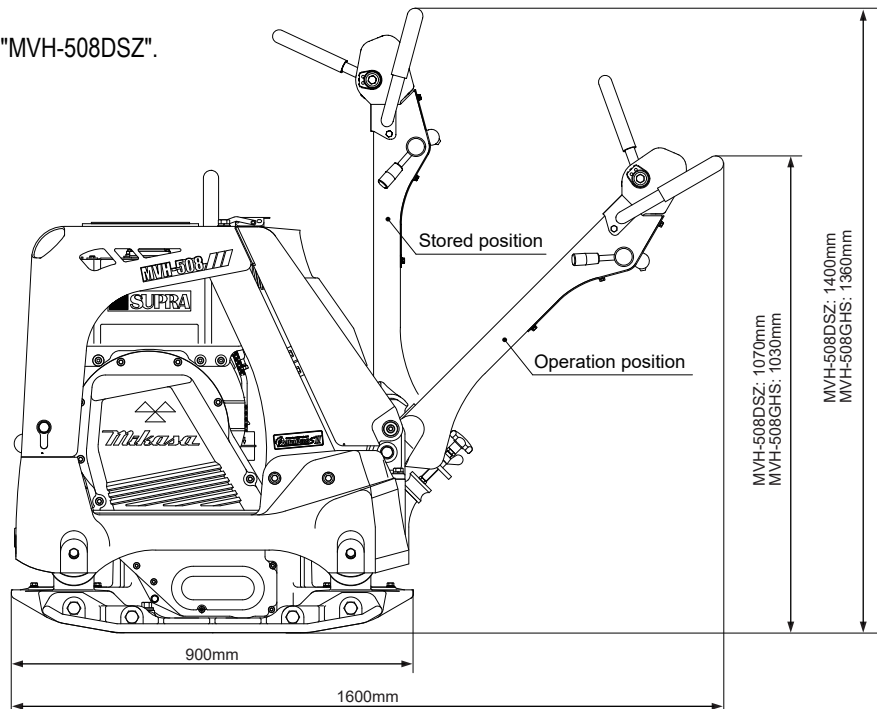
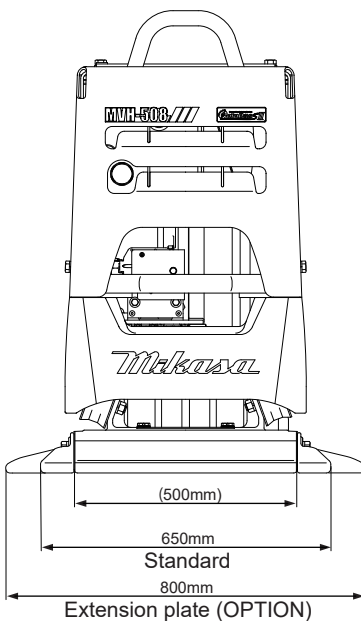

※ Specifications are subject to change without notice.

7. INSPECTION BEFORE OPERATION

Part inspection sheet before work start

Check point	Check item
Visual inspection	Flaw, Deformation
Front cover & center cover	Falling off, Breakage, Crack, Looseness and falling off of bolts & nuts
Fuel tank	Leak, Quantity, Dirt
Fuel system	Leak
Fuel filter	Dirt
Engine oil	Leak, Quantity, Dirt
Vibrator oil	Leak, Quantity, Dirt
V-belt for vibrator	Crack, Tension
Hydraulic piping	Leak, Looseness, Crack, Wear
Throttle lever	Operation check, Looseness, Play
Travel operation lever	Operation check, Looseness, Play
Bolts & Nuts	Looseness, Falling off

※ Regarding the engine inspection, refer to the engine operation manual.

CAUTION

Always stop the engine before inspection and set the machine on hard and level ground.

7.1 Engine Oil

- Check the oil level. If the oil level is low, fill oil. (Fig.1)

Regarding HATZ engine, it is available to fill oil from oil inlet located the its top too. (Fig.2)

Use the following engine oil.

Quality: Diesel engine oil, Grade CC or above
Gasoline engine oil, Grade SE or above
Viscosity: SAE No. 30 at 20°C and above (summer)
SAE10W-30

- ※ When filling oil from the oil inlet for HATZ engine, oil might overflow if large amount of oil is filled at one time. So, fill slowly.

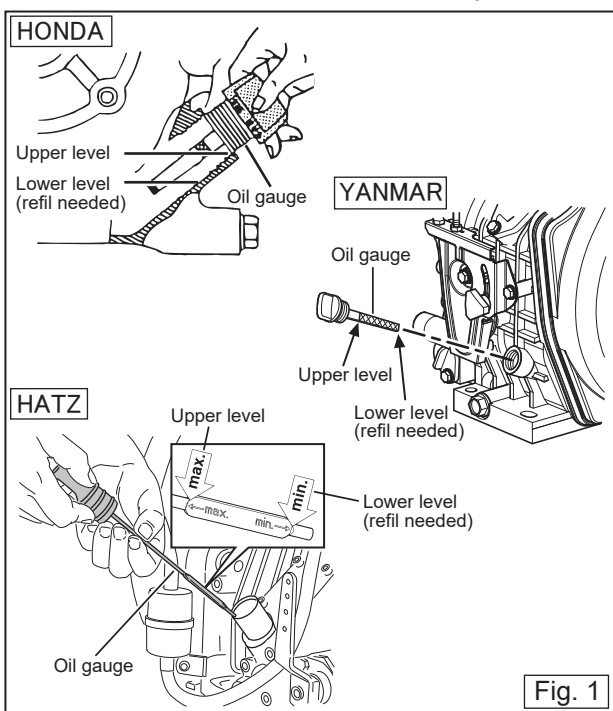

Fig. 1

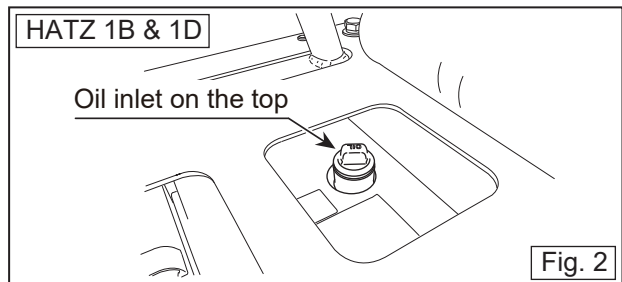

Fig. 2

7.2 Vibration Oil

- Check the vibrator oil level if it is at the specified level by removing the oil gauge or oil plug of vibrator. (Fig. 3)

Use engine oil SAE10W-30 as lubrication oil.
Vibrator oil capacity ⇒ 600cc

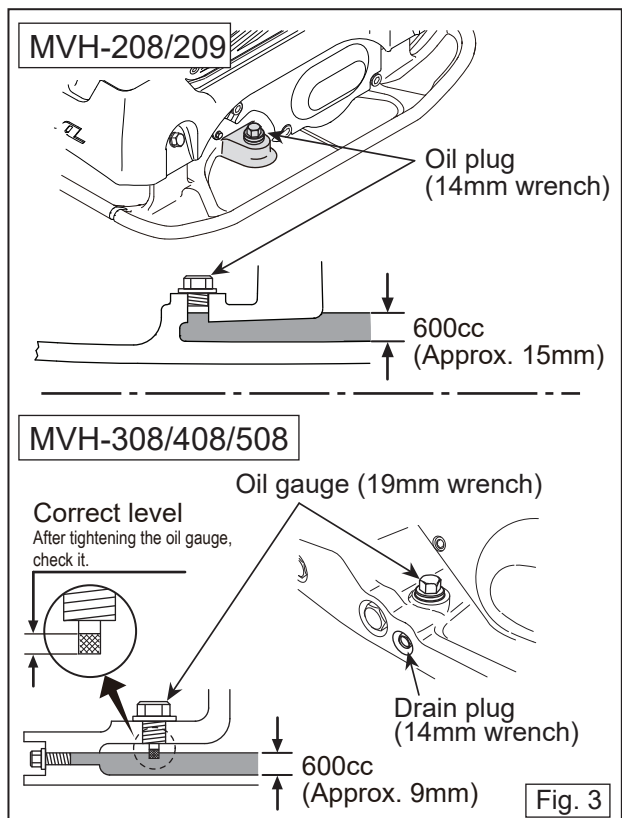

Fig. 3

7.3 Refueling

DANGER

- Stop the engine when refueling.
- Never refueling near a naked flames or a source of sparks
- Do not fill the fuel tank completely because the fuel might spill.
- Wipe up any spilled fuel.

- Use clean automotive gasoline or automotive light oil appropriate for the engine.
- Pass the fuel through a filter to filtrate when refueling.
- Fuel inlet is located under the rubber cover at the top of front cover.
- **Only HATZ engine:**
The fuel tank cap is equipped with a lock lever. Unlock this lever before opening the cap. (Fig.4)

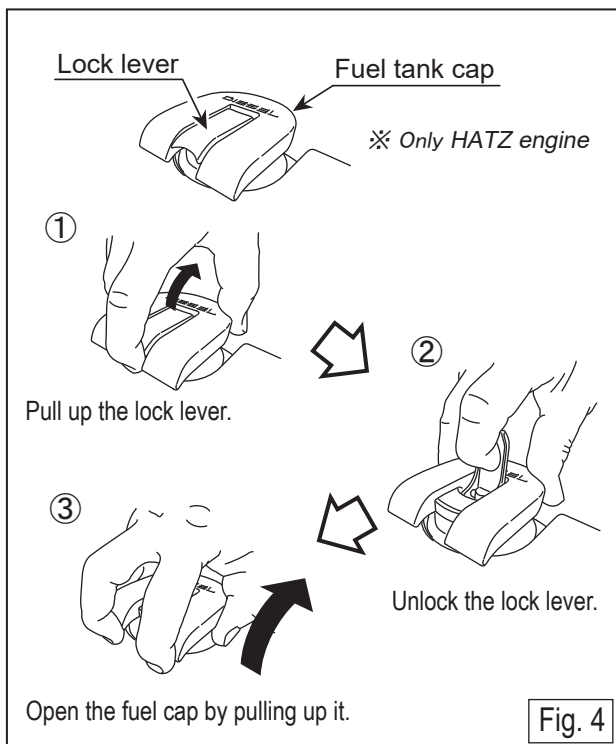

7.4 Handle

The height of the handle is adjustable for your comfort.(Fig.5)

● Adjust Handle Height

1. Loosen the wing nut.
2. Turn the grip clockwise to raise the handle or counterclockwise to lower the handle.
3. When the handle is raised to the desired height, tighten the wing nut.

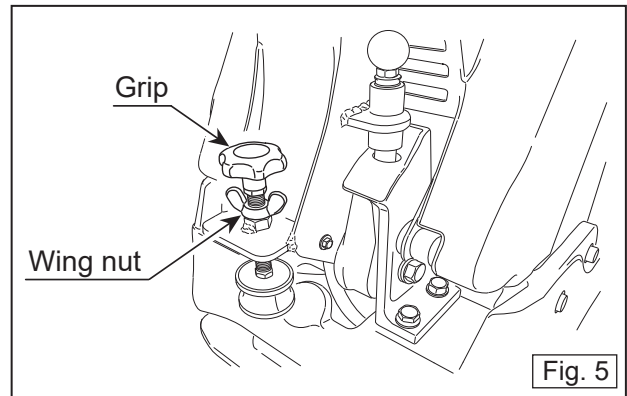

8. OPERATION

8.1 Starting

- 1 Move the handle from stored position to operation position by pulling the handle lock.

Gasoline Engine

- 1 Move the fuel cock lever to the "ON" position. (Fig. 6)

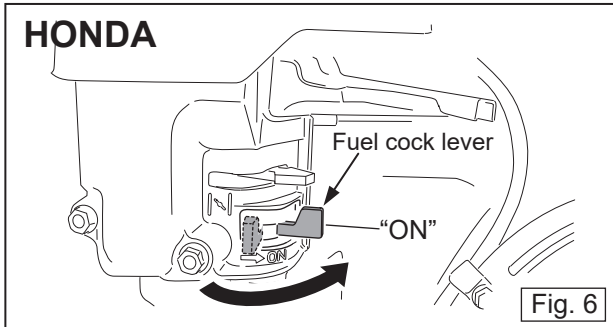

- 2 To start a cold engine, move the choke lever to the "CLOSED" position. To restart a warm engine, leave the choke lever in the "OPEN" position. (Fig. 7)

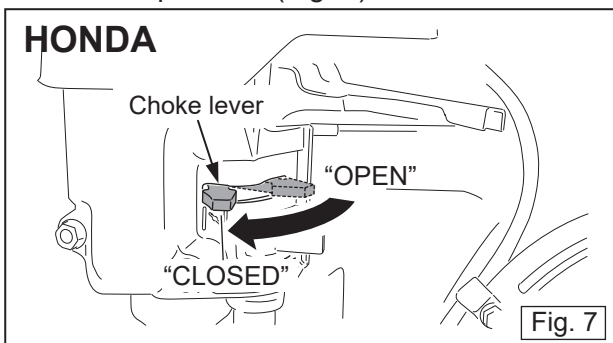

- 3 Move the throttle lever to the idle position. (Fig. 8)

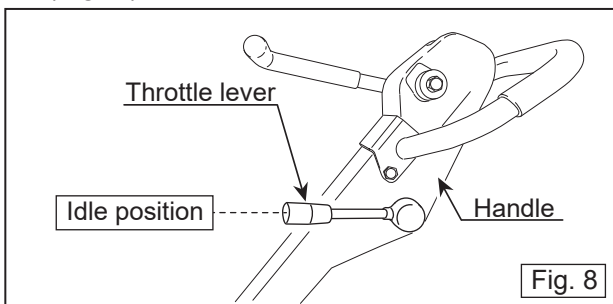

- 4 When the engine is stopped, the hour tachometer is always displaying "Operation Time". (Fig.9)

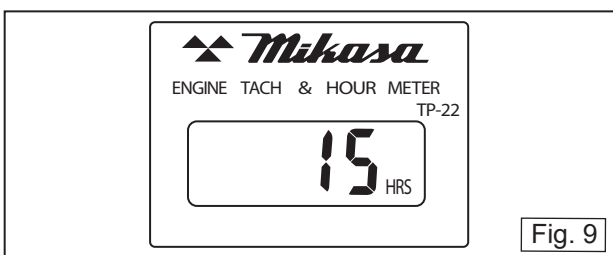

- 5 Operate the stater.

Recoil Starter

For MVH-208GH/209GH/308GH/408GH

- 5.1 Turn the engine switch to the "ON" position. (Fig.10)

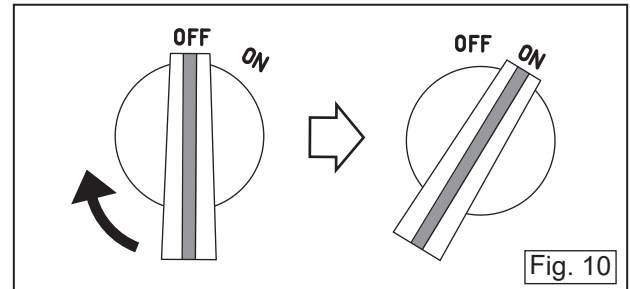

- 5.2 Pull the starter grip lightly until you feel resistance. Then, pull it briskly in the direction of the arrow as shown below. (Fig.11)

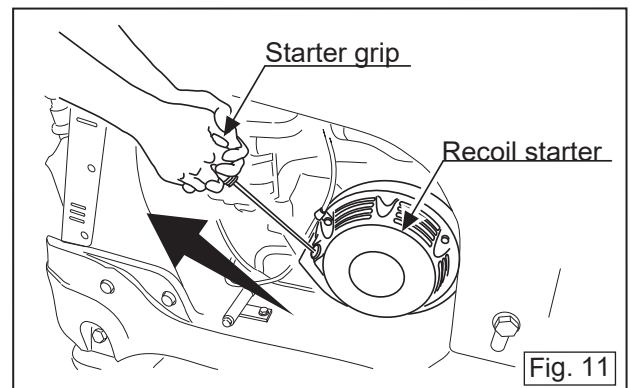

CAUTION

- Do not pull the starter grip all the length of the rope.
- Be careful not to pull it too hard as it might break or come off.
- Return it gently to prevent damage to the recoil starter.

Electric Starter

For MVH-508GHS

- 5.1 Insert the key to the key switch.
- 5.2 Turn the key to the "Run" position. (Fig.12)
- 5.3 Turn the key further to the "START" position to start the engine. After the engine is started, take your hand off the key. (Fig.12)

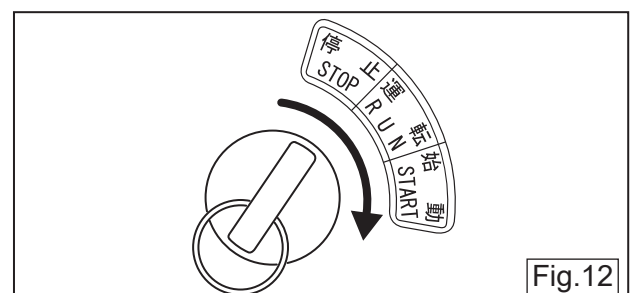

CAUTION

- When the engine does not start within 5 seconds, release the key, and wait for about 10 seconds at the "RUN" position before restarting.
- Do not use the electric starter for more than 5 seconds to prevent damage of the starter motor.
- While the engine is running, never turn the key switch to the "START" position.
- If using the recoil starter, turn the key switch to the "RUN" position.

- 6 If the choke lever has been moved to the "CLOSED" position to start the engine, gradually move it to the "OPEN" position as the engine warms up. (Fig.13)

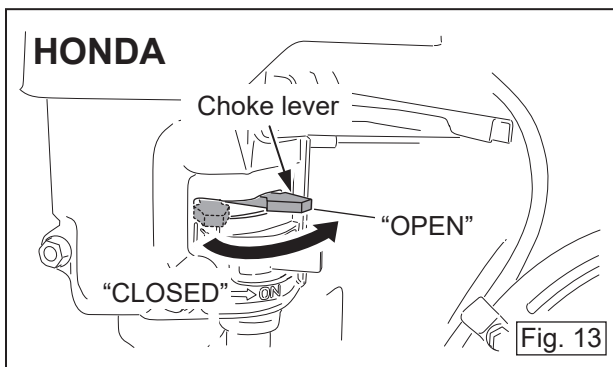

- 7 After the engine has started, warm up the engine at idle speed for 2 to 3 minutes. This is especially important in cold weather.

- 8 During operation, the hour tachometer is displaying "Engine Speed". (Fig.14)

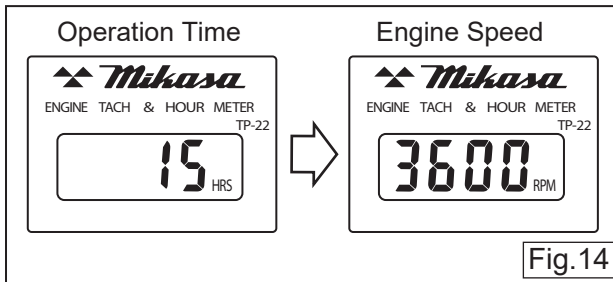

Diesel Engine

- 1 Move the fuel cock lever to the "ON" position. (Fig.15) (Only Yanmar engine)

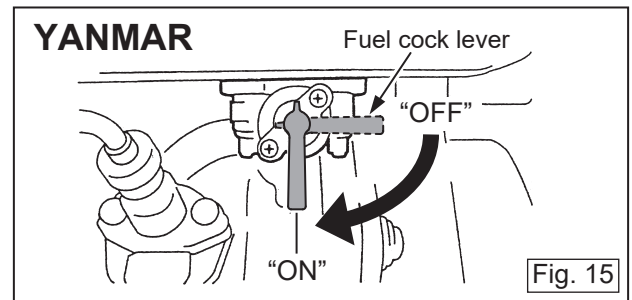

- 2 Insert the key to the key switch.
3 Move the throttle lever to the idle position. (Fig.16)

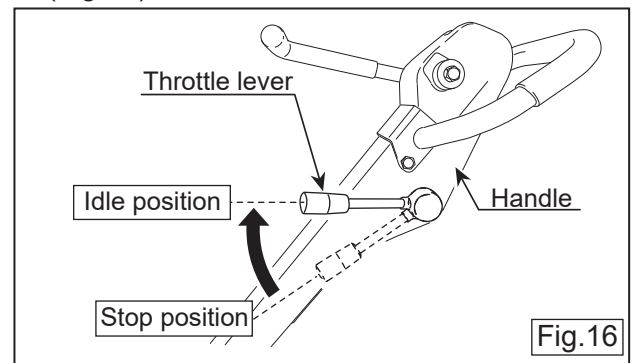

- 4 Turn the key to "RUN" position. (Fig.17)

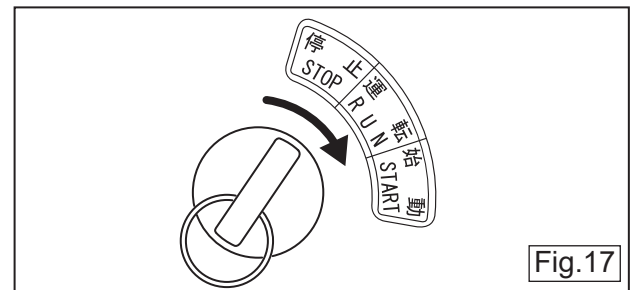

- 5 When turn the key to "RUN" position, the buzzer sounds. And the hour tachometer displays "Engine Type", then changes to display "Operation Time" immediately. (Fig. 18)

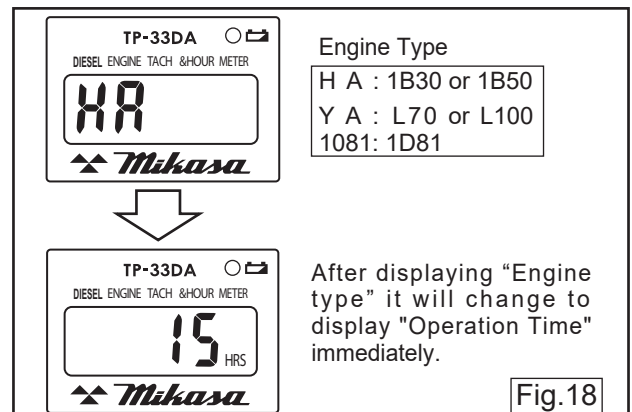

- 6 Operate the starter.

Electric Starter

6.1 Turn the key further to the "START" position to start the engine. After the engine is started, take your hand off the key. (Fig.19)

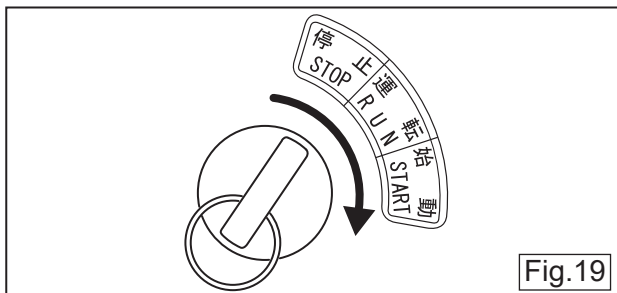

CAUTION

- When the engine does not start within 5 seconds, release the key, and wait for about 10 seconds at the "RUN" position before restarting.
- Do not use the electric starter for more than 5 seconds to prevent damage of the starter motor.
- While the engine is running, never turn the key switch to the "START" position.

Recoil Starter For Yanmar

6.1 Pull the starter grip lightly until you feel resistance. Then, slowly return it to the initial position. (Fig.20)

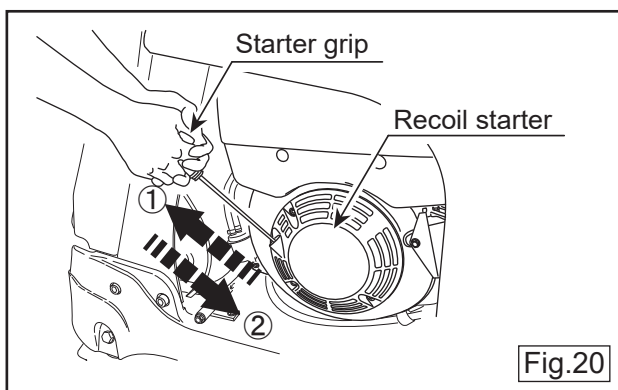

6.2 Push the decompression lever down and release it. The decompression lever will automatically return to the original position when the engine starts. (Fig.21)

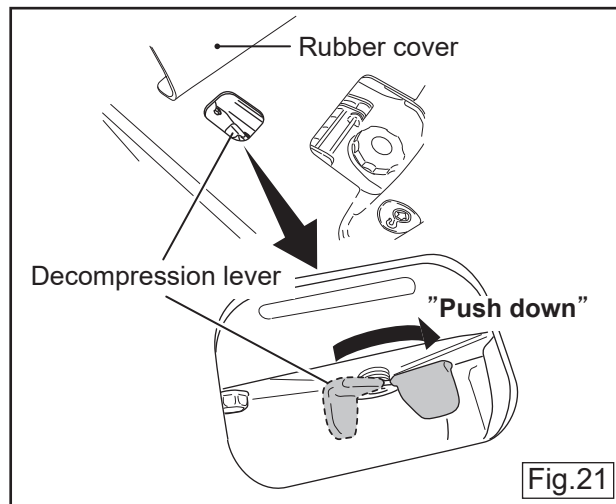

6.3 Pull the starter grip briskly all the way out. Use two hands if necessary. (Fig.22)

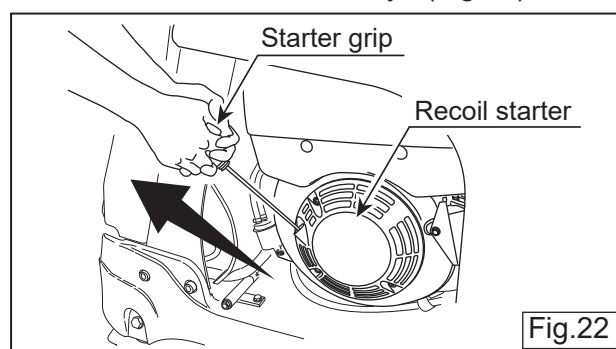

Recoil Starter For Hatz 1B30/1B50

6.1 Pull the starter grip lightly until you feel resistance. Then, slowly return it to the initial position.

6.2 Pull the starter grip briskly all the way out. Use two hands if necessary. (Fig.23)

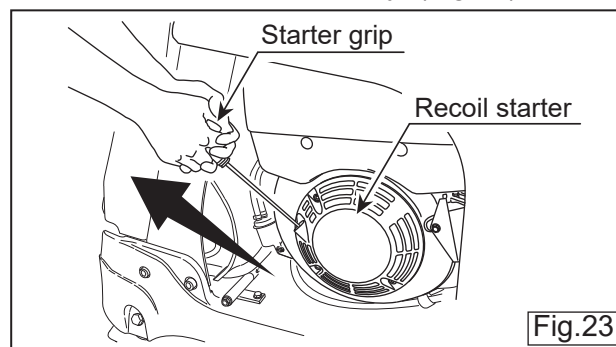

CAUTION

- Do not pull the starter grip all the length of the rope.
- Be careful not to pull it too hard as it might break or come off.
- Return it gently to prevent damage to the recoil starter.

Crank Handle Starter For Hatz 1D81

- 6.1 Pull up the decompression lever until starting position. The decompression lever will automatically return to the original position when the engine starts. (Fig.24)

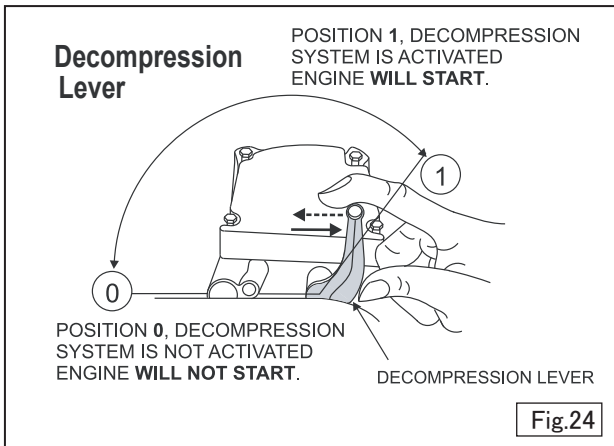

- 6.2 Insert the starting handle into the guide sleeve for starting handle of engine certainly. (Fig.25)

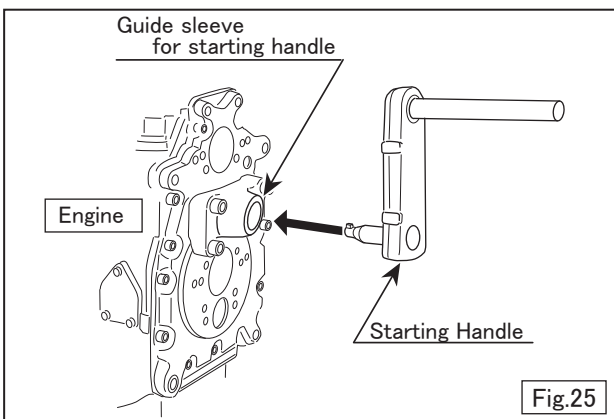

- 6.3 Observe the correct operating position when turning the starting handle. (Fig.26)

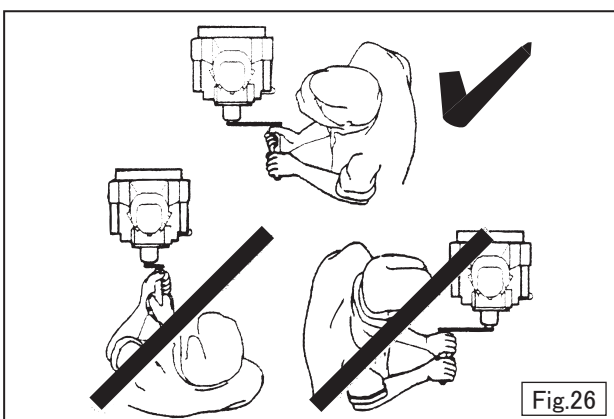

- 6.4 Grasp the starting handle firmly with both hands and turn counterclockwise at increasing speed. Five turns of the crank handle are needed to build up enough compression to start the engine.

- 6.5 Once the engine starts, stop cranking and remove the starting handle from the guide sleeve.

CAUTION

There is a risk of injury from the rotating starting handle. When using the starting handle, keep the body clear of the handle to avoid being struck.

If the engine backfires because the handle was not turned firmly enough, release the starting handle immediately and stop the engine.

- 7 When the engine starts, the buzzer stops.
- 8 After the engine has started, warm up the engine at idle speed for 2 to 3 minutes. This is especially important in cold weather.
- 9 During operation, the hour tachometer is displaying "Engine Speed". (Fig.27)

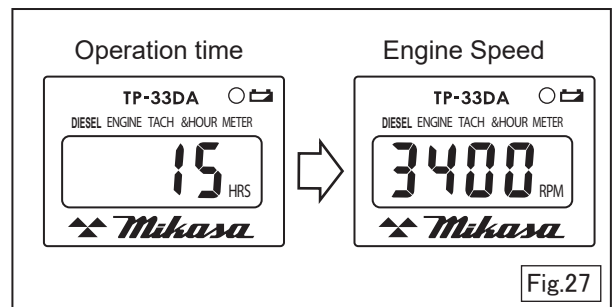

8.2 Operation

CAUTION

- During operation, pay sufficient attention to dangerous objects, obstacles, in the direction of your work and surrounding area.
- While in operation, never touch the moving parts and high temperature parts of the machine.

- 1 Once the engine has started, move the engine throttle lever quickly to the operation position. (Fig.28)

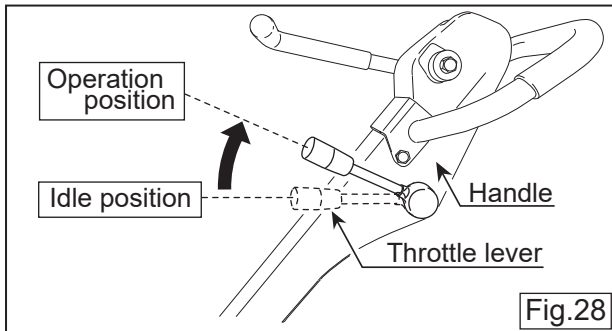

CAUTION

Always move the throttle lever quickly without hesitation, because increasing the engine speed slowly causes the clutch slipping.

- 2 Operate the travel operation lever to move the machine forward or reverse. The travel operation lever is normally in the forward position and the machine automatically moves forward. When pulled it to the reverse position, the machine moves reverse. In the neutral position, the machine compacts staying the same spot. (Fig.29)

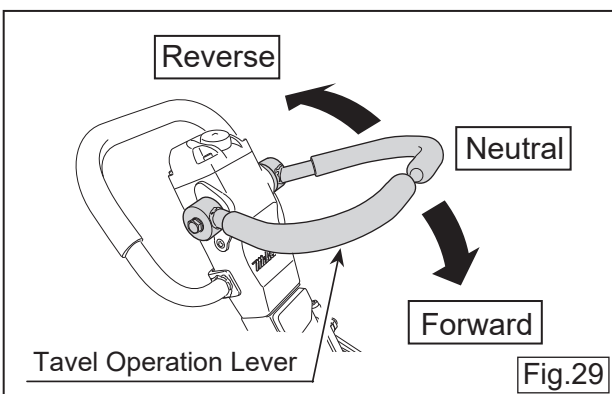

CAUTION

When this machine is used on ground that contains clay or high water percentage, the ground surface tends to stick to the vibrating plate, and the machine may slow down or not compact.

In this case, check the bottom of the vibrating plate to see if there is adhered any clay to it. Dry the ground until becoming the appropriate ground condition before using this machine to get good compaction performance.

- 4 If you want to suspend the work, the throttle lever return to the idle position quickly. (Fig.29)

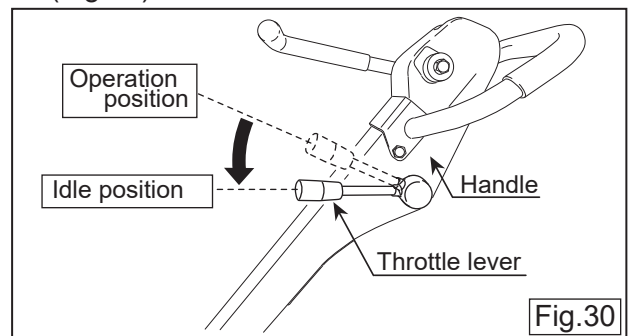

CAUTION

When you move the throttle lever to the idle position, do not return it to the operation position suddenly before the engine speed has slowed completely. It may cause engine failure.

8.3 Compaction Sensor (Compas II)

Compaction sensor (Compas II) is a system that uses acceleration sensor to show real-time soil stiffness with LED (light-emitting diode) lights based on the number of compactions done.

This compaction sensor improves efficiency of compaction work because it can prevent the area already properly compacted from being compacted more than necessary and to identify the area where more compaction is needed. The sensor also has a function to detect abnormality such as vibration trouble (insufficient vibration frequency), ground trouble (soft soil) and functional issues. (Fig. 31)

NOTE

What is shown by the compaction sensor (Compas II) is not the absolute value of the soil stiffness.

When using the sensor, always calculate appropriate soil stiffness by conducting plate load test and dynamic load test (FWD), etc. to calibrate the LED lighting level with the actual measurement value.

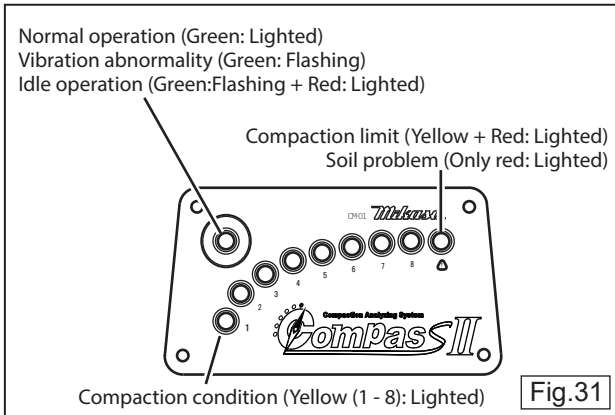

1 Normal compaction (during compacting)
Green LED lights up when the sensor finds that the machine is in normal compaction process. When the revolution goes up, and compaction starts, the yellow LED ① lights up, and as the compaction proceeds, the number of the lighted LEDs increases from ② to ⑧. After the LED light that was calibrated with the measured soil stiffness value lights up, the compaction process completes. (Fig. 32)

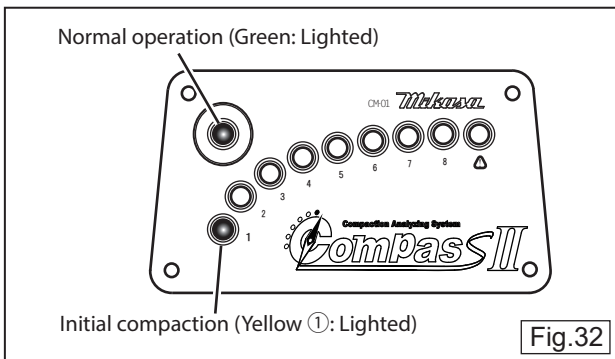

2 Normal compaction (Compaction limit)
Compaction limit is reached when all the yellow LEDs from ① to ⑧ have lit up and the red LED lights up. At this point, this machine cannot do any further compaction. If higher soil stiffness value is required, please use a machine of higher level. (Fig. 33)

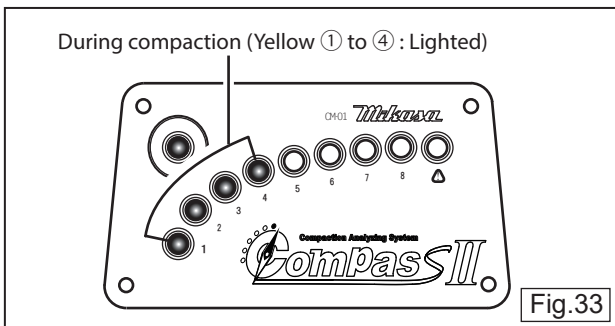

3 Function to detect abnormality
3-1 Detection of ground trouble and soft ground
For a case of unstable ground or soft ground (soil containing clay) for which the use of this machine is not suitable, only the red LED lights up, with no yellow LED illuminated.

If that happens, because you cannot expect sufficient compaction, do ground improvement work before proceeding with the compaction process. (Fig. 34)

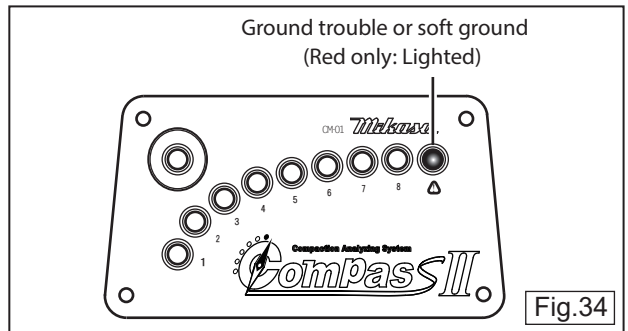

3-2 Detection of vibration abnormality
During operation when appropriate vibration frequency cannot be achieved because of the specified engine revolution or the loosened drive belt, or when the vibration frequency is too high, it is indicated by the flashing light. (Fig. 35)

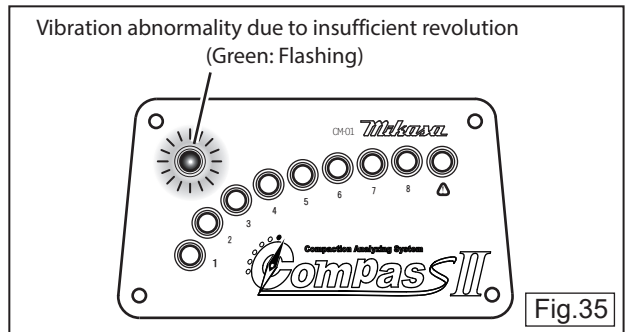

4 Function to detect electric system abnormality
4-1 Sensor wire disconnection
(Between acceleration sensor and sensor panel)
If flashing of red LED and green LED alternates as shown in the figure, please check the sensor wire because there is a possibility that it is disconnected. (Fig. 36)

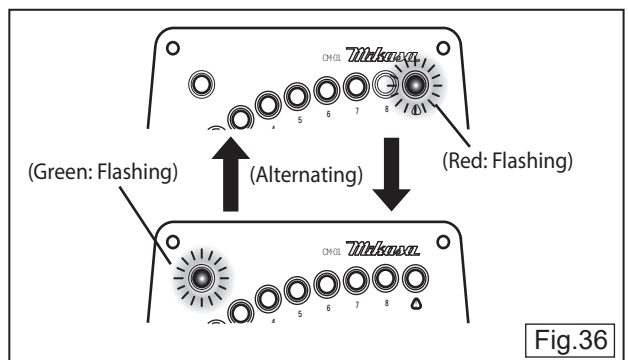

4-2 Power cable disconnection
(Between battery and sensor panel)
If there is no power even when the key switch is turned on, please check because there is a possibility that the power cable is disconnected.

9. STOPPING THE MACHINE

CAUTION

Never stop the engine suddenly while working at high speeds. It might cause engine failure.

Gasoline Engine

- 1 Move the throttle lever to the idle position. Cool down the engine for 3 to 5 minutes at idle speeds before stopping.

For MVH-208GH/209GH/308GH408GH

- 2 Turn the engine switch to the OFF position. (Fig. 37)

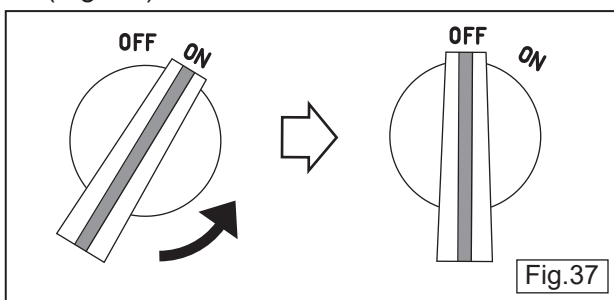

For MVH-508GHS

- 2 Turn the key to the "STOP" position. (Fig.38)

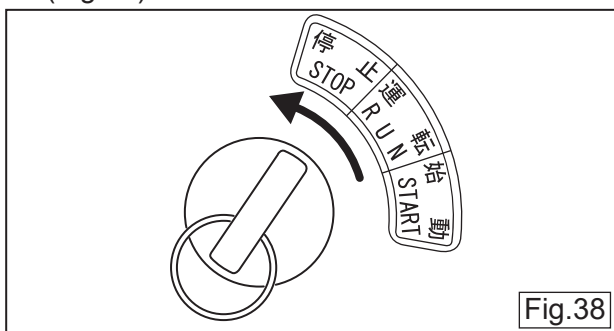

- 3 Move the fuel cock lever to the "OFF" position. (Fig. 39)

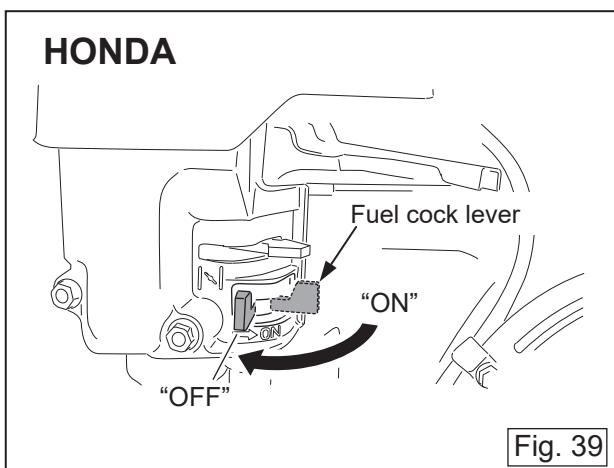

Diesel Engine

- 1 Move the throttle lever to idle position. Cool down the engine for 3 to 5 minutes at idle speeds before stopping.
- 2 Move the throttle lever to the stop position to stop the engine. When the engine stops, the buzzer sounds. (Fig. 40)

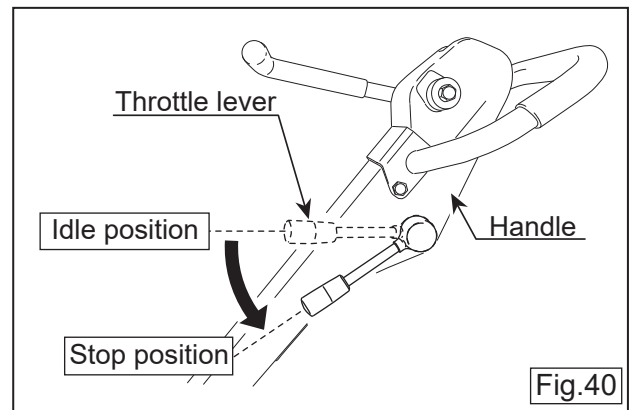

CAUTION

When the throttle lever is moved from the idle position to the stop position, the engine stops. Before the engine stops completely, do not move the throttle lever to the idle or operation position suddenly. It might cause engine failure.

- 3 When turn the key to "STOP" position, the buzzer stops. (Fig. 38)
- 4 Move the fuel cock lever to the "OFF" position. (Fig. 41) (Only Yanmar engine)

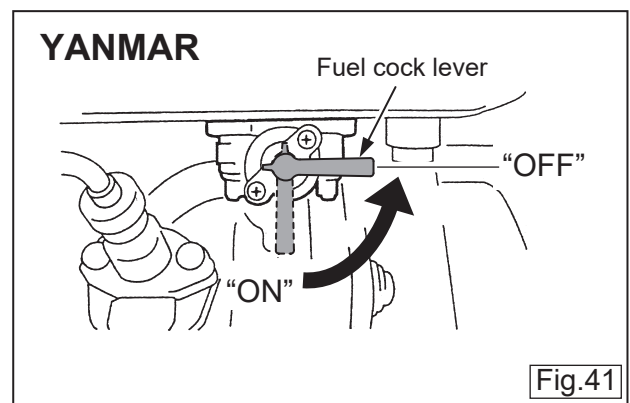

10. TRANSPORTATION AND STORAGE

10.1 Loading And Unloading

WARNING

- Make sure there is no breakage of guard frame and shock absorbers nor loosened or missing bolts.
- Always stop the engine when lifting.
- Use an intact lifting cable (wire or rope) without any deformation with sufficient strength.
- Slowly lift upward without applying any impact. Never let people or animals go under the lifted machine.
- For safety reasons, do not lift to a height that is higher than necessary.

- 1 Use a crane or lift for loading and unloading the machine.
- 2 Designate a person to guide the loading and unloading, and always work under the instruction of that person.
- 3 When lifting, always use a hook. (Fig. 42)
Never lift by using the hook on the handle.

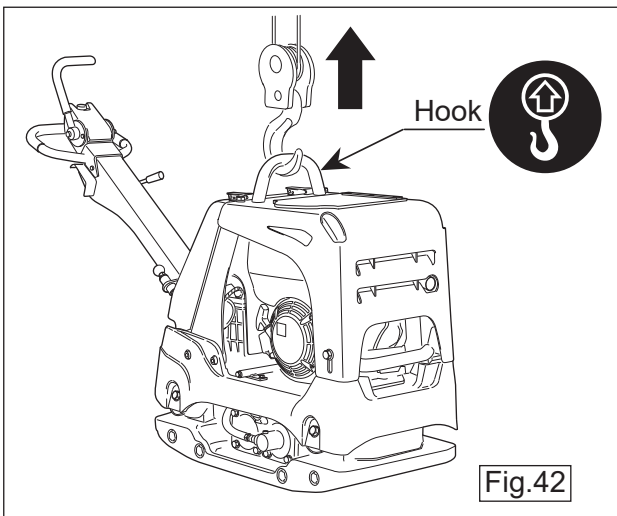

10.2 Transportation Precautions

WARNING

- Stop the engine when the machine is transported.
 - Always drain the fuel before transportation.
 - Fix the machine securely to prevent the machine from moving or falling.
-
- When putting the handle into the stored position (vertical position), make sure it is properly locked.
 - When transporting, remove the starter key.

10.3 Storage

- Wash off dirt and soil from every part with water. While washing, be careful not to do the water splashed on the electric components such as the battery and the engine muffler part.
- Store in a dry and clean place avoiding direct sunlight after covering the machine with plastic covering or equivalent.
- Do not leave the machine outdoors. Place it indoors.
- When not used for a long period of time, drain the fuel from the fuel tank, and either disconnect the battery terminal or remove the battery itself.
- When the machine is used after a long storage period, check the level of engine oil and battery capacity.

11. REGULAR CHECK AND ADJUSTMENT

11.1 Inspection And Maintenance Schedule Table

Inspection interval	Check parts	Check items	Oils
Daily (before starting)	Appearance	Flaw, Deformation	
	Fuel tank	Leakage, Oil level, Dirt	Light oil, gasoline
	Fuel system	Leakage, Oil level, Dirt	
	Engine oil	Leakage, Oil level, Dirt	Engine oil
	Shock absorber	Crack, Damage, Wear	
	Hand pump	Leakage	Hydraulic oil
	Vibrator oil	Leakage	Engine oil
	Hydraulic piping	Leakage, Looseness, Flaw, Wear	Hydraulic oil
	Air cleaner	Dust, Dirt	
	Guard frame	Breakage, Flaw, Loose or missing bolts and nuts	
	Throttle lever	Operation check, Looseness, Backlash	
	Travel operation lever	Operation check, Looseness, Backlash	
	Bolts and nuts	Looseness, Falling off	
	Duct hose	Crack, Damage	
Every 20 hours	Engine oil	Replace only after the first 20 hours	
	Engine oil filter	Replace only after the first 20 hours	
Every 100 hours	Engine oil	Change	Engine oil
	Engine oil filter	Washing	
	Vibrator oil	Leakage, Oil level, Dirt	Engine oil
	Hydraulic oil	Leakage, Oil level, Dirt	Hydraulic oil
	Battery terminal	Cleaning	
Every 200 hours	V-belt for vibrator	Flaw, Tension	
	Clutch	Dirt, Flaw, Wear	
Every 300 hours	Vibrator oil	Change	Engine oil
	Hydraulic oil	Change	Hydraulic oil
	Fuel filter	Change	
	Engine oil filter	Change	
Every 2 years	Fuel pipes	Change	
Irregular	Air cleaner element	Change	
	Hydraulic hose	Change	
	Cyclone cleaner	Cleaning	

For details about the inspection and maintenance of the engine, please refer to the attached engine operation manual.

Caution: The above table shows the inspection interval under normal condition.

The inspection interval may vary depending on the condition in which the machine is used.

For check of bolt and nut looseness and tightening, please see the following tightening torque list.

Tightening torque list (unit: kgf-cm, 1kgf-cm=9.80665N-cm)

		Thread diameter							
		6mm	8mm	10mm	12mm	14mm	16mm	18mm	20mm
Material	4T(SS400)	70	150	300	500	750	1,100	1,400	2,000
	6-8T(S45C)	100	250	500	800	1,300	2,000	2,700	3,800
	11T(SCM435)	150	400	800	1,200	2,000	2,900	4,200	5,600
	When the mating material is aluminum.	100	300~350	650~700	(Bolts used on the machine are all right-hand thread.)				

CAUTION

- Always stop the engine before maintenance and set the machine on hard and level ground.
- Start your work after the machine and engine cool down completely.
- Be careful to get caught the finger when opening and closing the front cover.
- Do not touch the hot parts because the engine and muffler become very hot.

11.2 Open The Front Cover

- Makes easier inspection and maintenance.
- 1 Remove the bolts on the front cover. Loosen the bolts on the side of front cover without removing them. (Fig.43)

Model	Bolt Size
MVH-208,209	M12X35
MVH-308,408,508	M14X45

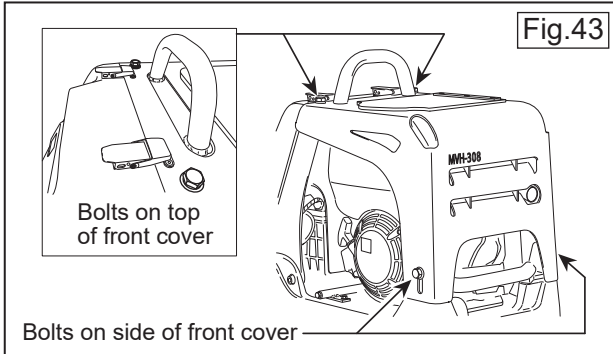

- 2 Hold the side of front cover, and pull up it to open position. (Fig.44)

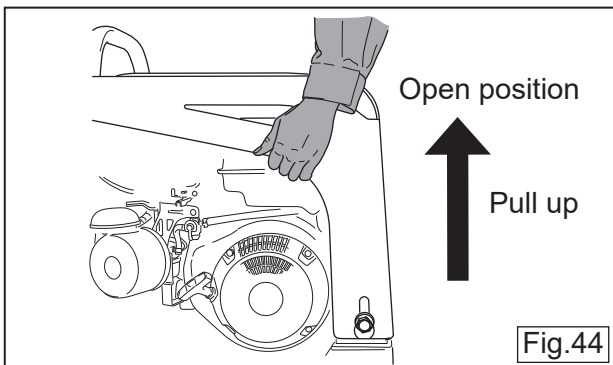

- 3 Open the front cover slowly.(Fig.45)

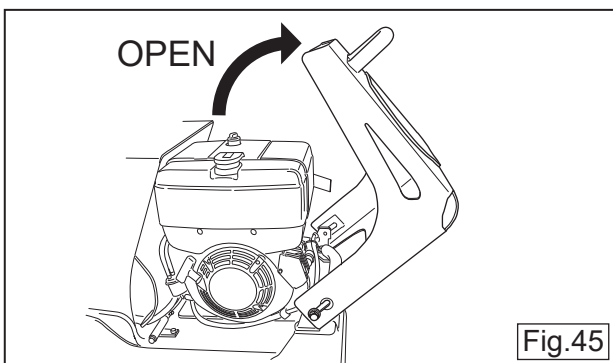

- 4 Return the front cover to original position slowly.Tighten the bolts in the specified torque. (Fig.46)

Size	Tightening torque	Remarks
Bolt M12X35	117.6N·m (86.8lbf·ft)	Apply Loctite #243
Bolt M14X45	176.6N·m (130.2lbf·ft)	Apply Loctite #243

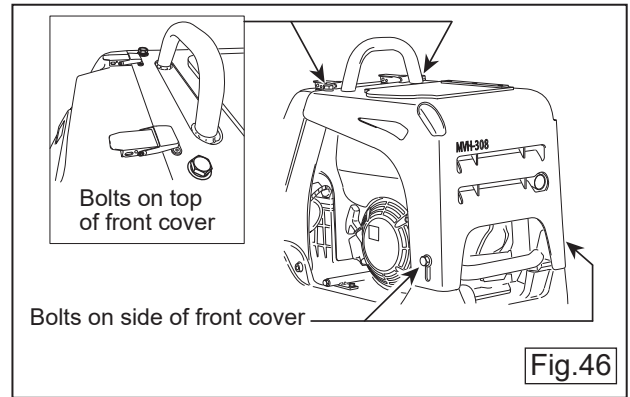

CAUTION

- Do not return the front cover in its open position.
- Do not start the engine when opening the front cover.
- Tighten the bolts firmly.

11.3 Change The Engine Oil

- Change the engine oil, first in 20 hours of operation and every 100 hours afterwards. (Fig.47)

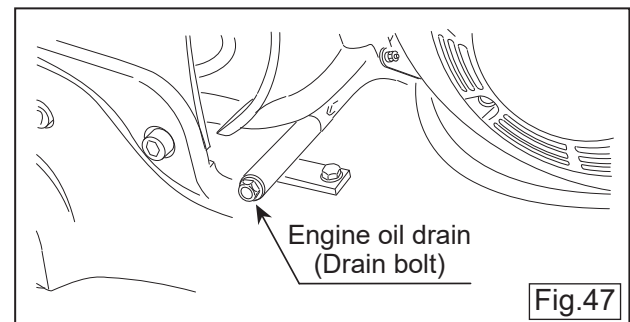

11.4 Clean The Air Cleaner

● Engine Air Cleaner

When the air cleaner element becomes dirty, the engine will not start smoothly, and will not get sufficient output.

It will affect the machine operation and will short the engine life greatly.

Do not forget to clean the element. (For details, please see the separate engine operation manual.)

If the element cannot be cleaned, replace it with a new one. (Fig.48)

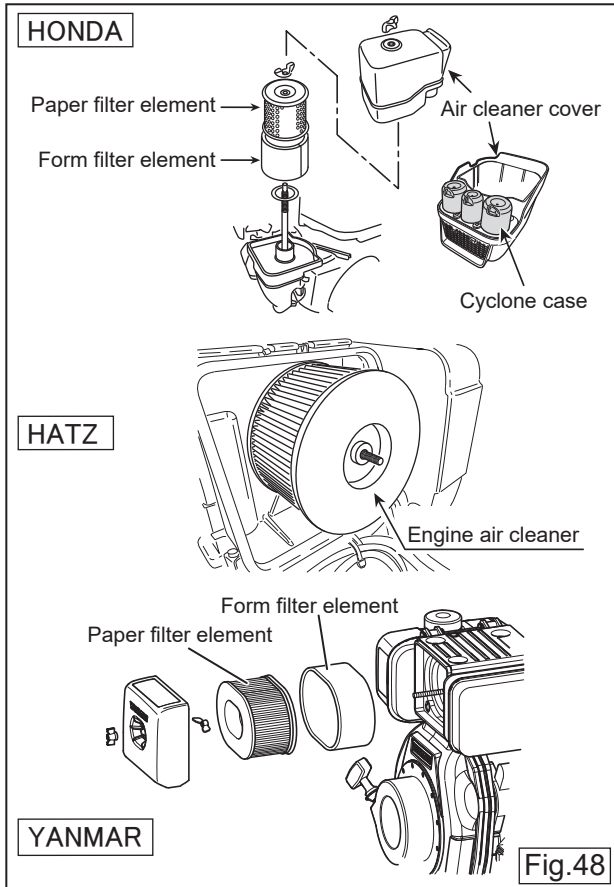

● Cyclone Cleaner

Always clean the dust pot of cyclone cleaner. Clogged dust pot will reduce cyclone effect and will clog cleaner element easily.

● How to clean the dust pot

- i) Take off the latch of dust pot and remove it. (Fig.49)

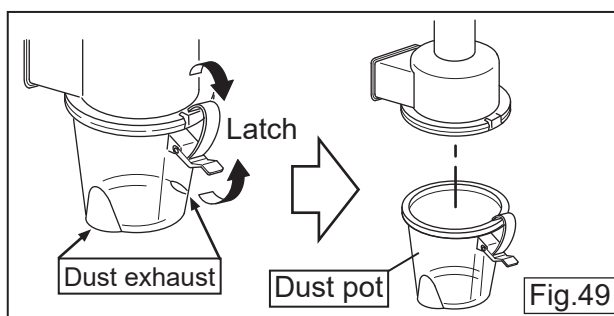

⚠ CAUTION

Be careful to avoid pinched fingers.

- ii) Clean the dust pot inside with water and neutral detergent.

⚠ CAUTION

Do not use organic solvent like paint thinner, which may cause damage or deformation of Dust Pot.

- iii) Set the dust pot to air cleaner, then fasten the latch of it securely. (Fig. 50)

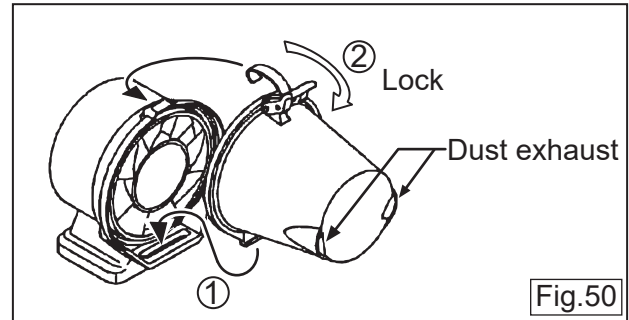

11.5 Check/Change The V-belt

1 Check of V-belt (Fig. 51)

At every 200 hours, remove the belt cover (upper) to check the tension of the V-belt.

The V-belt tension is proper if V-belt bends 10 to 15 mm when depressed with finger at midway between the clutch and vibration pulley.

A loose V-belt will decrease the power transmission output, causing reduced compaction and premature wear of the V-belt.

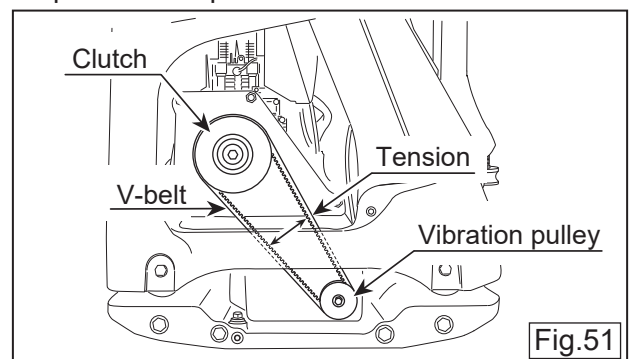

2 Change the V-belt

● Remove the V-belt

Remove the upper and lower belt covers. Engage the wrench to the tightening bolt of the vibrator pulley (lower side). Engage waste cloth or the like at the midway of the V-belt on the left side, and while pulling it back strongly, rotate the wrench clockwise so that the V-belt will come off.

● Install the V-belt

Engage the V-belt to the lower vibrator pulley and push the V-belt to the left side of the upper clutch, and rotate the tightening bolt of lower vibrator pulley clockwise with the wrench so that the V-belt moves onto the pulley.

⚠ CAUTION

- Stop the engine when checking or changing the V-belt.
- Be careful not to get caught your hand or clothes between the V-belt and the clutch.
- Always wear work gloves.

11.6 Check/Change The vibrator Oil

- At every 100 hours of operation, check the vibrator oil level if it is within the allowable range by removing the oil gauge or oil plug of vibrator. (Fig.52)
- At every 300 hours operation, change the vibrator oil.
 - MVH-208/209:
For draining the oil from the port of oil plug, tilt the machine with a sleeper or the like placed under the vibrating plate or use the oil changer.
 - MVH-308/408/508:
Drain the oil from the drain plug.

Use engine oil SAE10W-30 as lubrication oil.
Vibrator oil capacity ⇒ 600cc

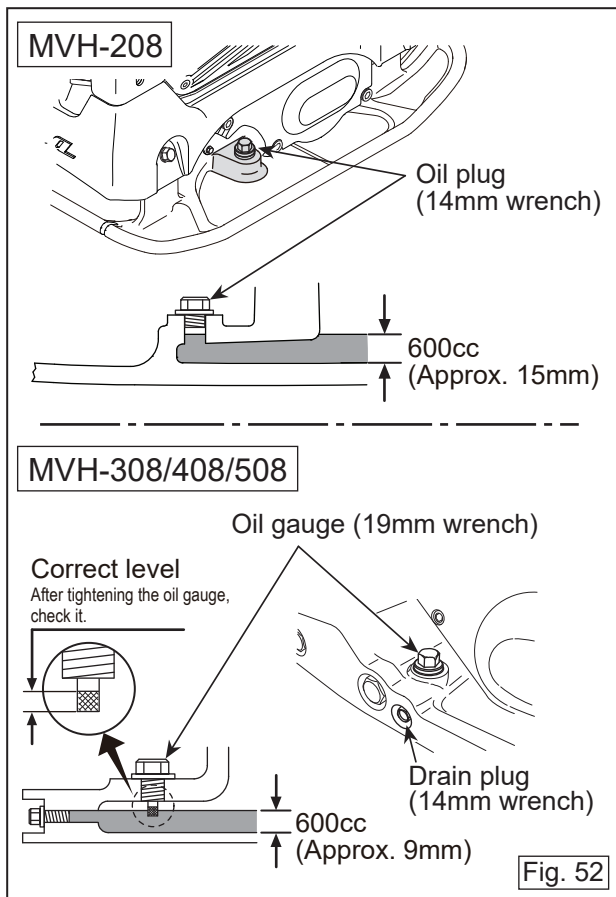

⚠ CAUTION

- Appropriate maintenance is required to ensure safe and efficient operation of the machine.
- Pay special attention to the parts used for lifting, if they are not maintained properly, it might result in a serious accident.
- When checking the vibrator oil, clean around the oil plug beforehand to prevent entering dust and other foreign materials into the vibrator oil.
- Whenever there is an oil leakage from the vibrator, check the oil level.
- After draining the vibrator oil, some oil still remains in vibrator case. So be sure to check the oil level correctly after filling oil.
- Do not overfill the vibrator oil. The engine is overloaded and It may cause the increased fuel consumption and lower machine performance.

11.7 Check/Change The Hydraulic Oil

● Check the hydraulic oil

At every 100 hours of operation, check the hydraulic oil. With the handle at the operation position, remove the breather plug at the top of the hand pump and check if the hydraulic oil is at the specified level (OIL LEVEL). (Fig. 53)

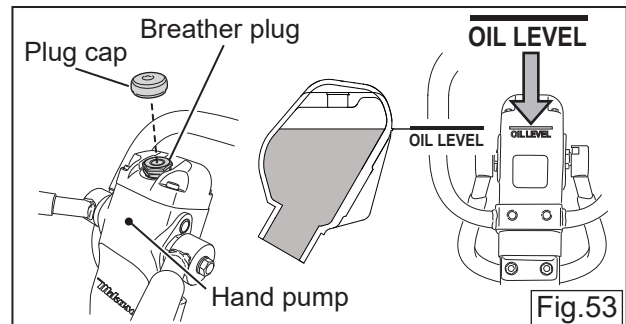

● Change the hydraulic oil

- 1 Remove the plug cap of the hand pump, then remove the breather plug (with 24mm wrench). (Fig.53)
- 2 Remove the hydraulic hose connected to the cylinder on the vibrator and fix the travel operation lever at maximum forward position with rope, then drain the hydraulic oil in the hand pump. (Fig.54)

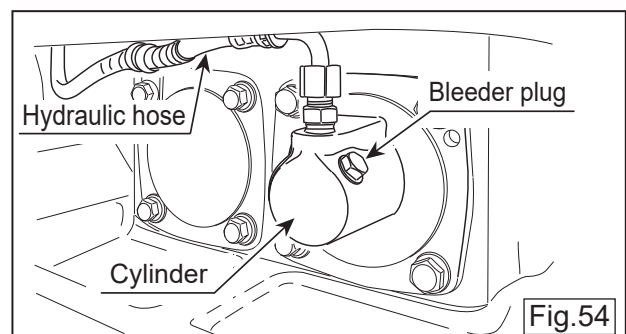

- 3 After draining, reassemble the hydraulic hose to the cylinder on the vibrator. (Fig.54)
- 4 Fill the hydraulic oil from the hole of breather plug on the hand pump. (Fig.53)

CAUTION

- The hydraulic oil should be at OIL LEVEL. Do not overfill. Overfilling will cause to blow out excess oil from the breather plug.
- Be careful not entering dust and other foreign materials into the hand pump during inspection or replacement. It may cause hand pump failure.

- 5 Loosen the bleeder plug located at the top of cylinder on the vibrator, after a while oil with air bubbles will come out. After air bubbles in oil are free, tighten the bleeder plug firmly. (Fig.54)

- 6 Remove the handle cover, then the travel operation lever move to the maximum forward and reverse position several dozen times.

The check valve in the hand pump is opened at the maximum forward position and air bubble will come out from the oil tank of the hand pump.

Air bleeding is complete when the accumulator cylinder of the hand pump moves 2 - 3 cm as shown in Figure 55.

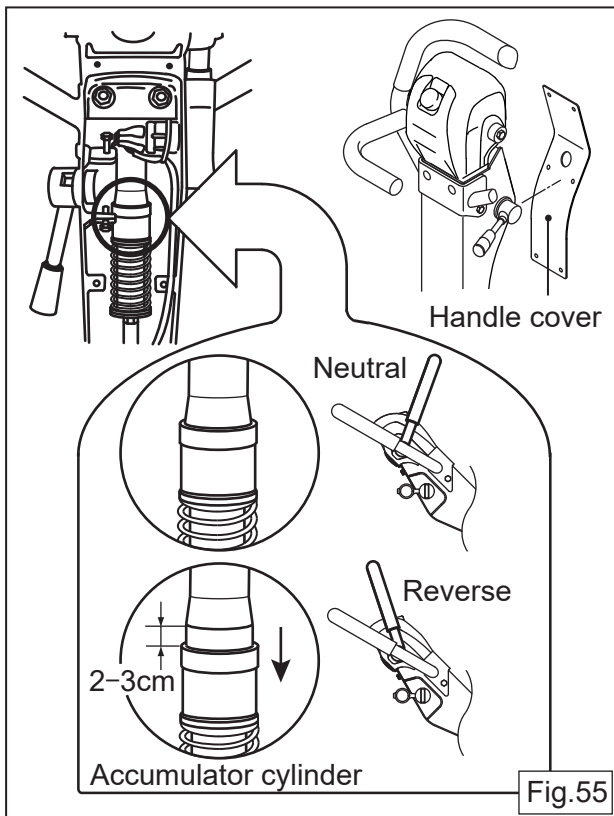

Fig.55

- 7 After making sure to check that the hydraulic oil should be at OIL LEVEL, reassemble the breather plug of the hand pump. (Fig.53)

Hydraulic oil:
Shell Terrace Oil #32 or equivalent
Hydraulic oil capacity: 550cc

11.8 Battery

- Check the battery
The standard battery installed is a maintenance free battery. It is not necessary to supply battery fluid. If the battery voltage is low and cannot be charged, replace it with a new battery.
- Check of battery capacity by battery checker (Only diesel engine)
When the battery charge level is low, the battery checker of the hour tachometer lights up in red.(Fig.56)

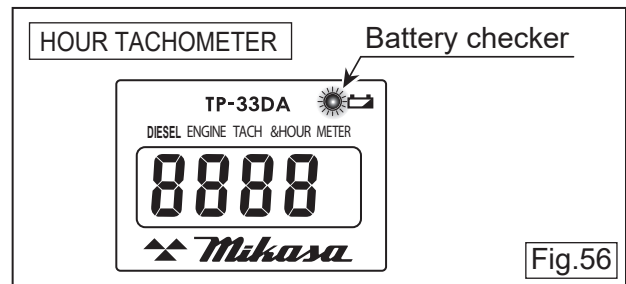

Fig.56

CAUTION

If the old battery is used, even when the battery checker is not lighted, the electric starter might not operate. In this case, change the battery with the new one.

How to remove the battery

Diesel Engine

- 1 Remove the two catch clip on the top of rear cover, then open the rear cover. (Fig.57)

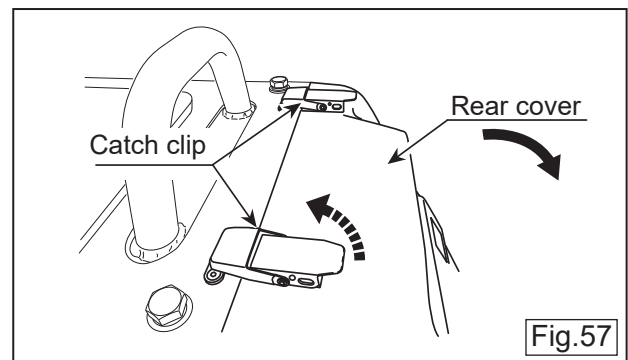
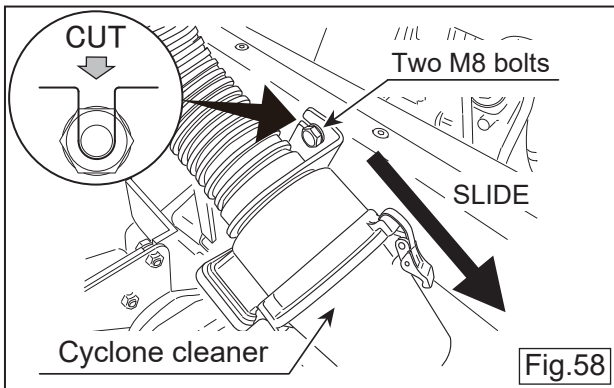
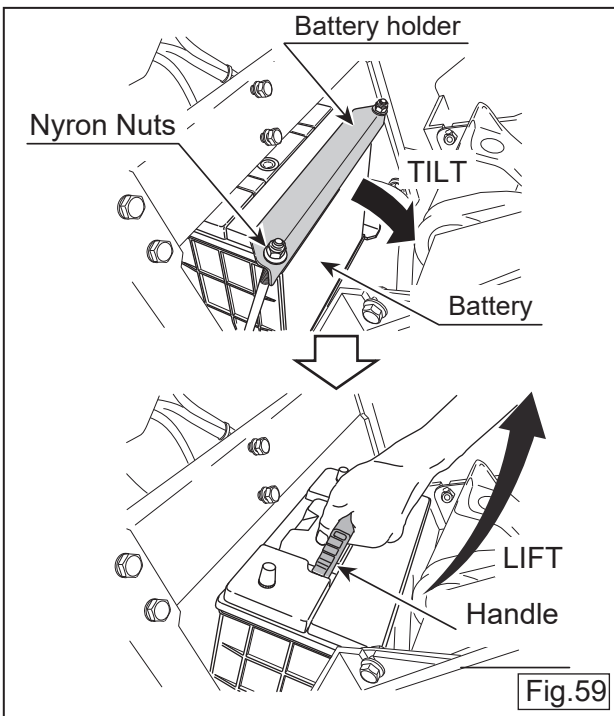

Fig.57

- Loosen the two M8 bolts securing the cyclone cleaner without removing them, then remove the cyclone cleaner. (Fig.58)



- Disconnect the negative (Black) terminal of the battery first. Then, disconnect the positive terminal (RED) of the battery.
- Remove the two nuts and the battery holder. Then, tilt the battery backward and remove the battery by lifting up with its handle. (Fig.59)



Gasoline Engine without COMPAS II

- Remove the battery from the open space in the rear cover, which is covered by the rubber cover.
- How to remove the battery is the same as diesel engine. Refer to them.
- When removing the battery holder, remove it with the rubber plate. (Fig.60)

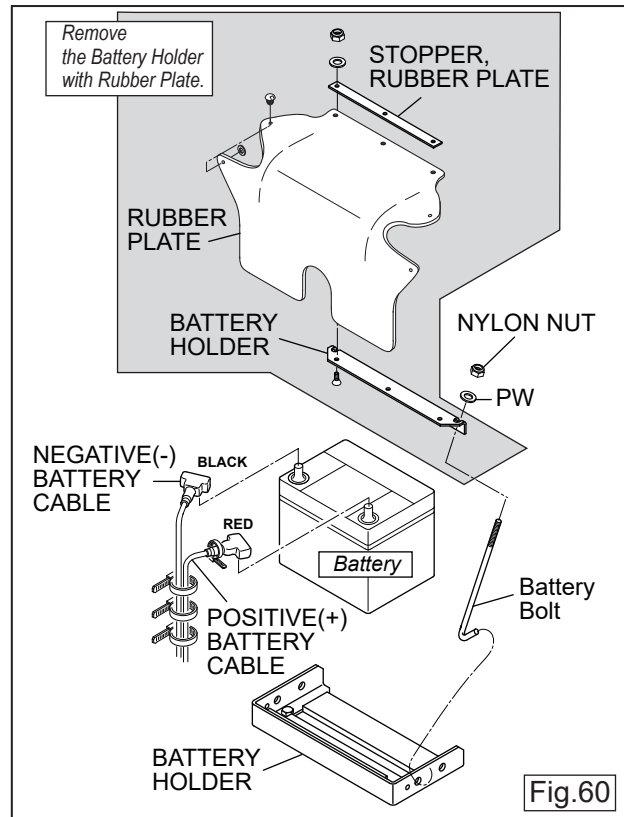

Gasoline Engine with COMPAS II

- Remove the compas panel by removing the seven M6 socket head screws first. (Fig.61)

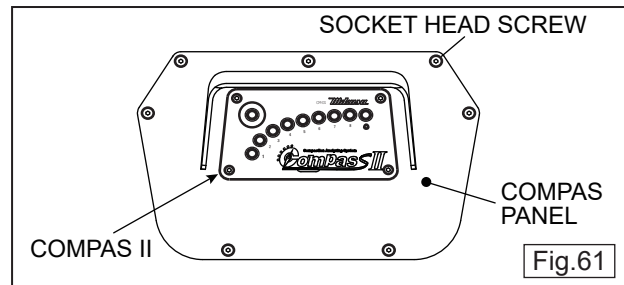

How to assemble the battery

- Assemble the battery with the reverse procedure of removing the battery.
- Connect positive terminal (RED) of the battery first. Then, connect the negative (Black) terminal of the battery.

⚠ DANGER

- Do not operate the machine without the battery holder. There is a risk of electric shock or electric leakage.

⚠ CAUTION

- Pay sufficient attention so that the battery terminal will not touch the main body.
- When charging the battery, always remove it from the machine.

● Mountable battery size table

	L	W	H	SIZE	
MVH-308	238	129	203	55B24L(JIS) No.51R(BCI)	STD
	245	175	175	DIN 55Ah or equivalent	Replacement
	245	175	190		
	245	129	203	JIS/BCI TYPE Maximum capacity	
	245	175	190	DIN TYPE Maximum capacity	
MVH-408 MVH-508GHS	238	129	203	55B24L (JIS) No.51R(BCI)	STD
	232	175	203	※ 75D23L(JIS) No.35(BCI)	Replacement
	245	175	175	DIN 55Ah or equivalent	
	245	175	190		
	245	175	203	Maximum capacity	
MVH-508	232	175	203	75D23L(JIS) No.35(BCI)	STD
	245	175	175	DIN 75Ah or equivalent	Replacement
	245	175	190		
	245	175	203	Maximum capacity	

12. TROUBLESHOOTING

12.1 Gasoline Engine

(1) Starting problems

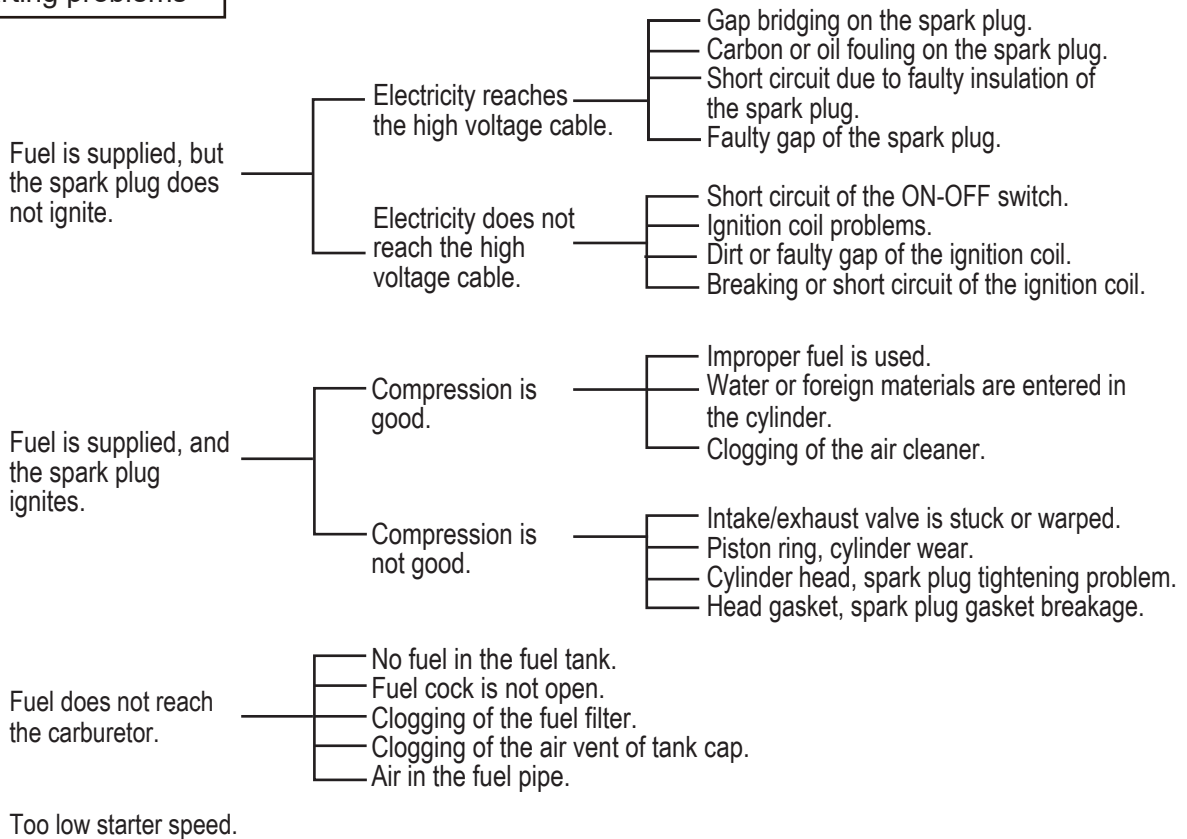

(2) Operation problems

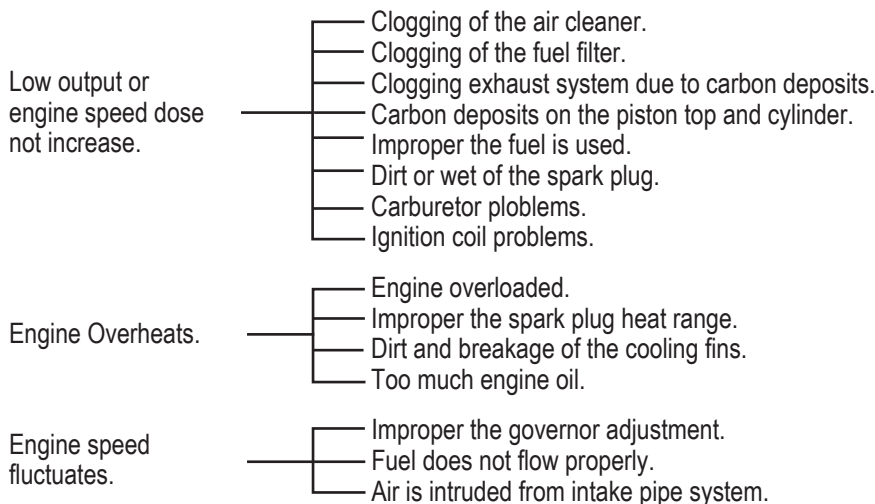

(3) Recoil starter problems

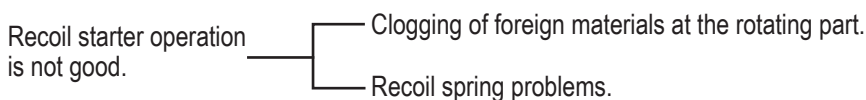

12.2 Diesel Engine

(1) Starting problems

(A) In case of compression problems

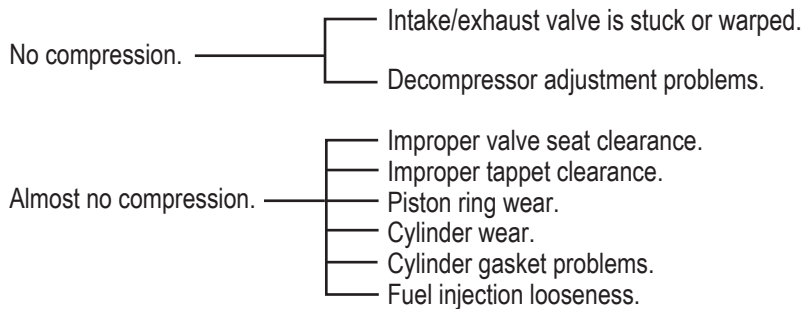

(B) In case of fuel injection problems

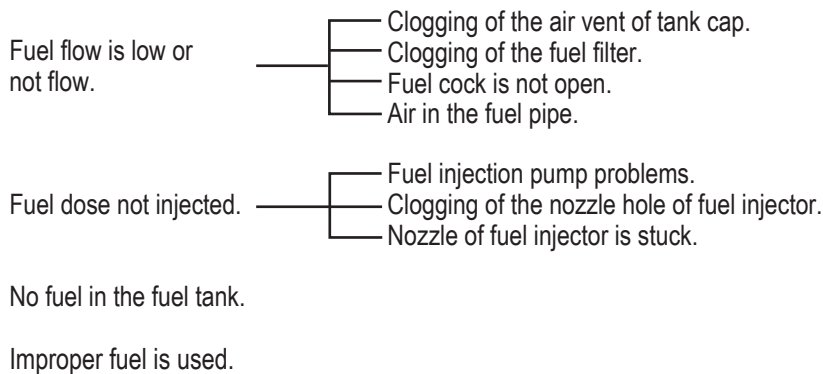

(C) Fuel and compression are normal, but the engine does not start yet.

- Improper starting procedure.
- Too low starter speed.

(2) Operation problems

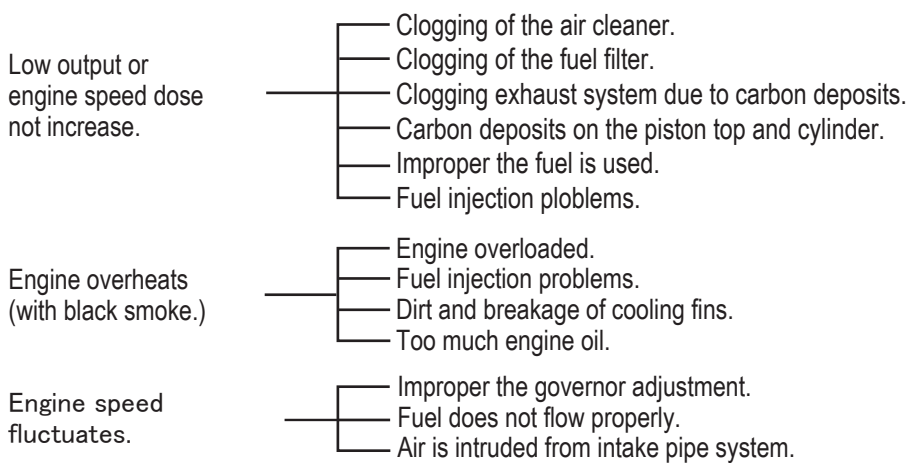

Firing problems
(with white smoke)

- Piston, piston ring, cylinder wear.
- Piston ring stuck.
- Piston ring is installed upside down.
- Fuel injection problems.
- Improper the valve seat clearance.
- Improper the tappet clearance.
- Improper the injection timing
- Water is mixed with in fuel.

Fuel economy is
too low.
(with black smoke)

- Engine is overloaded.
- Fuel leaks from the fuel system.
- Clogging of the air cleaner.
- Fuel injection problems.

Sliding part extremely
is worn or
piston ring is stuck.

- Improper engine oil is used.
- Engine oil is not changed.
- Without the air cleaner.
- Breakage of the air cleaner.

Stopped suddenly with abnormal noise. ————— Seizure of the sliding part of the engine.

Engine oil is increased. ————— Engine oil is diluted with fuel due to internal leakage of the fuel injection.

Engine does not stop
even though the fuel
supply is off
(or over-running)

- Engine overheats.
- Carbon deposits on the piston top and cylinder.
- Too much the engine oil.

12.3 Main Body

Travel speed is low
and vibration is weak.

- Insufficient the engine output.
- Improper operating speed of the engine.
- Slipping of the clutch.
- Slipping of the V-belt.
- Settling of the shock absorber.
- Too much the vibrator oil.
- Failure inside the vibrator.

Moves to forward or
reverse, but unable
to switch direction.

- Hand pump problems.
- Clogging of the valve inside the hand pump.
- Hydraulic oil leaks from the oil seal in the hand pump.
- Breakage of the hydraulic oil hose.
- Air in the hydraulic oil hose.
- Hydraulic oil leaks from the piston in the cylinder on the vibrator.

Dose not move to
forward and reverse.

- Breakage or coming off of the V-belt.
- Breakage or slipping of the clutch.
- Breakage of the vibrator.

Travel operation lever
is heavy.

- Hand pump problems.
- Piston and cylinder on the vibrator problems.

13. WIRING DIAGRAM

MVH-308DSY MVH-408DSY

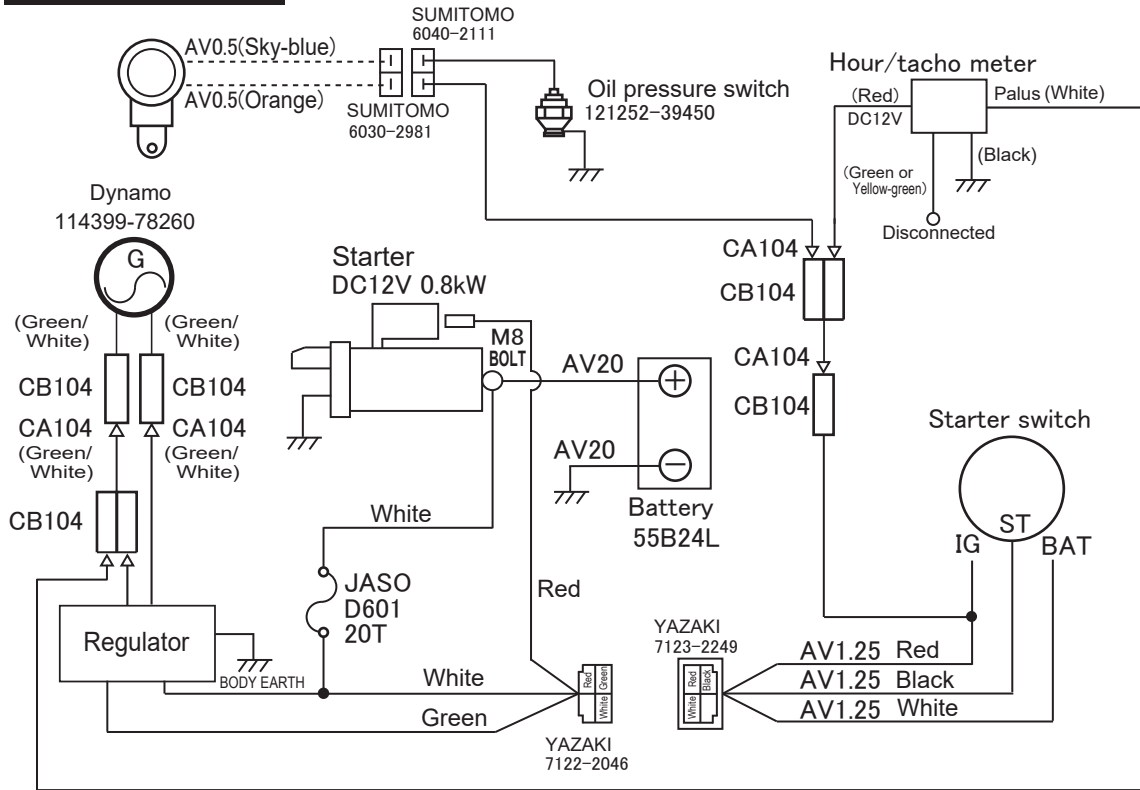

MVH-308DSY-PAS MVH-408DSY-PAS

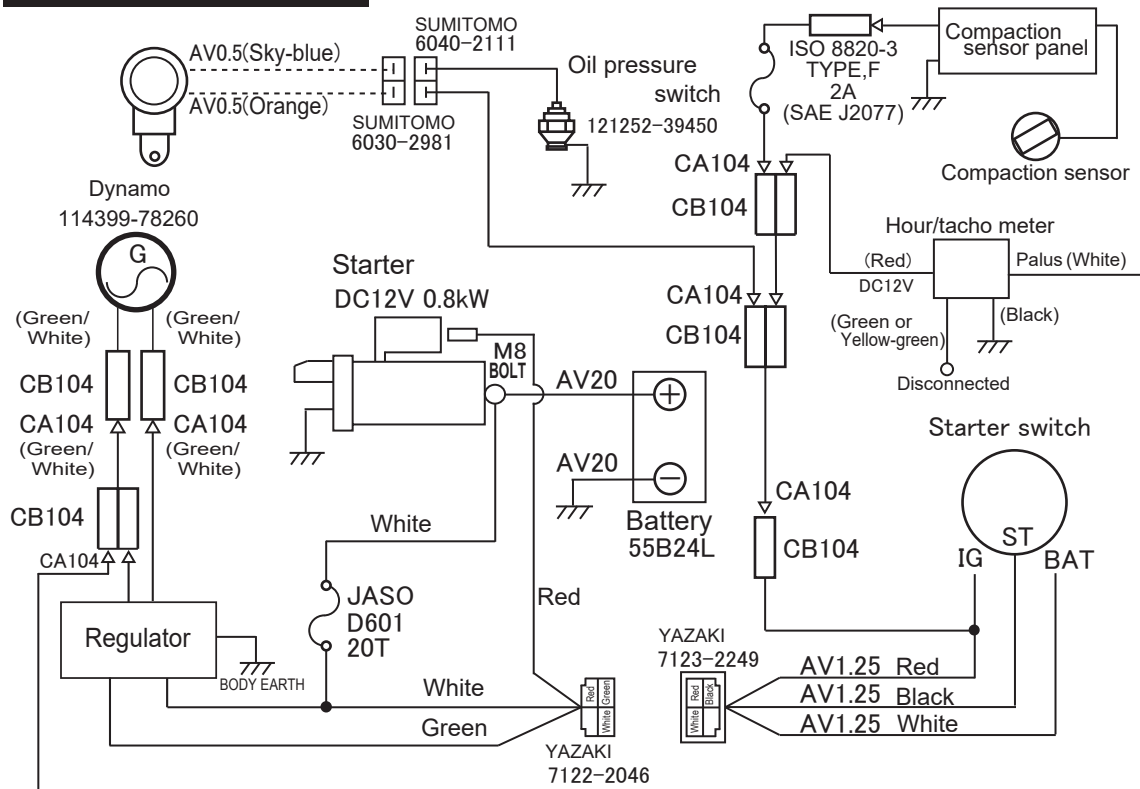

**MVH-308DSZ
MVH-408DSZ**

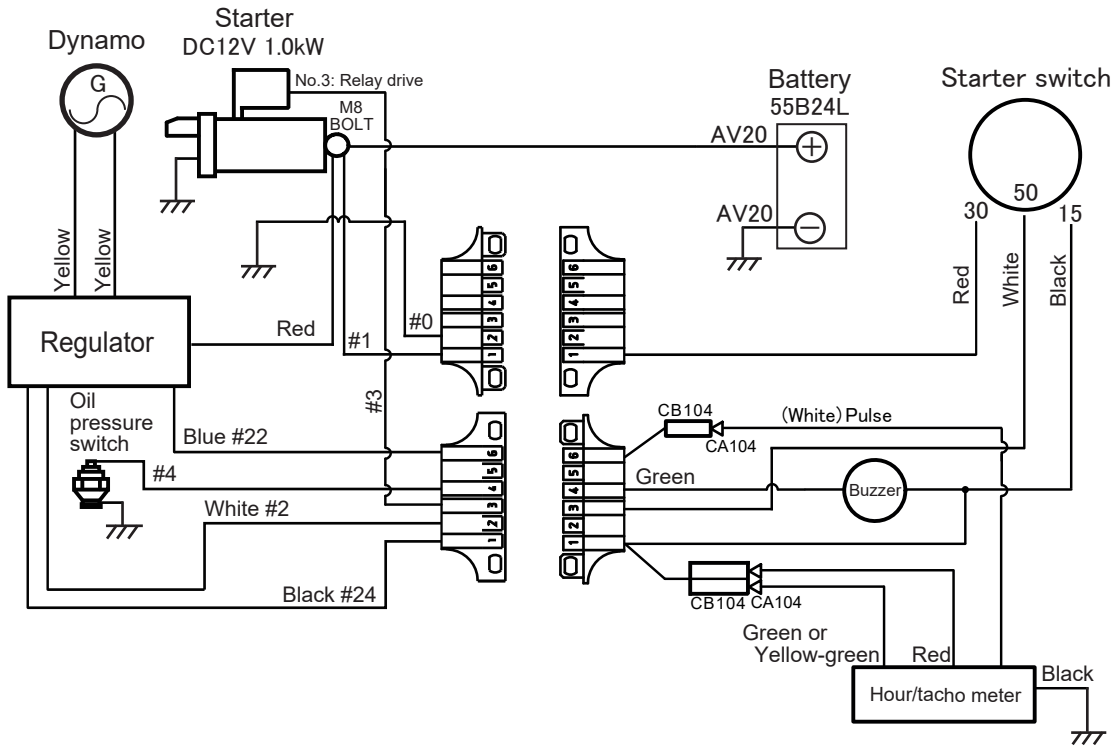

**MVH-308DSZ-PAS
MVH-408DSZ-PAS**

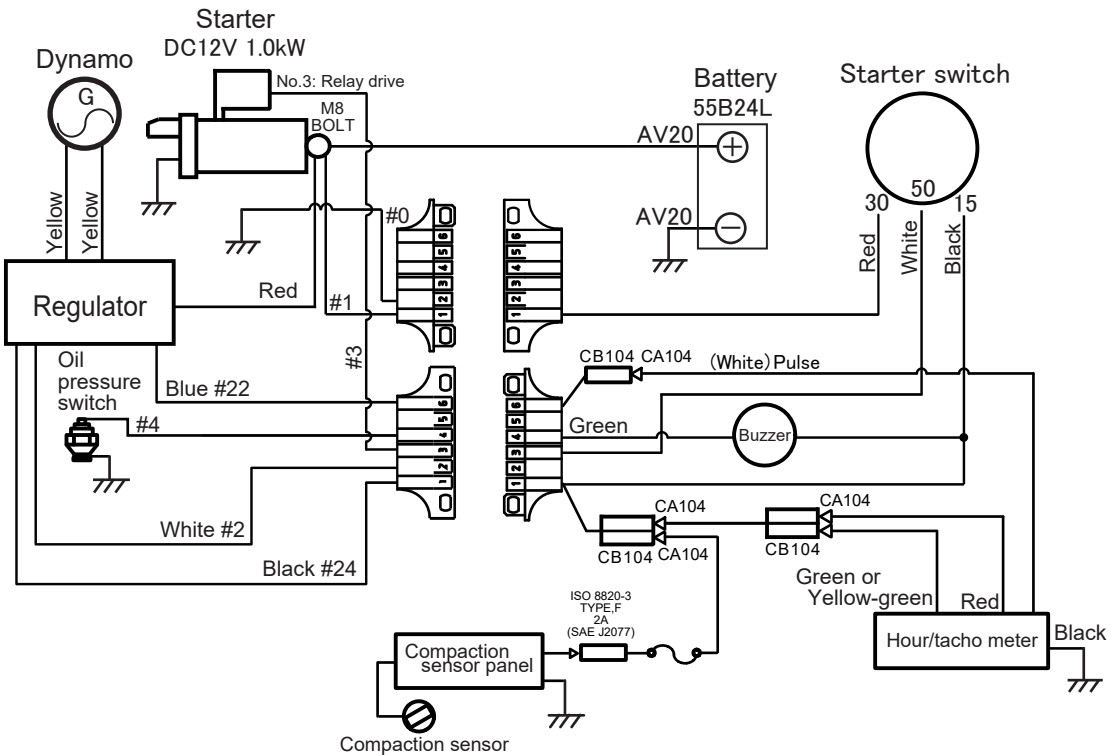

MVH-508DSZ

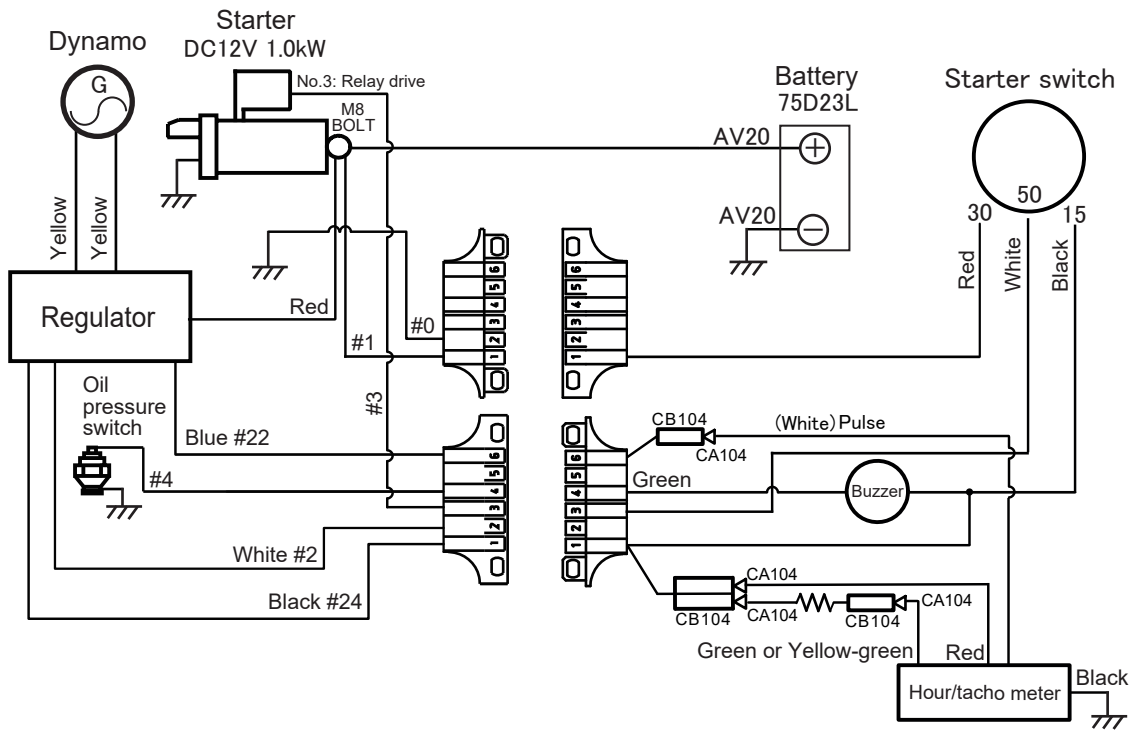

MVH-508DSZ-PAS

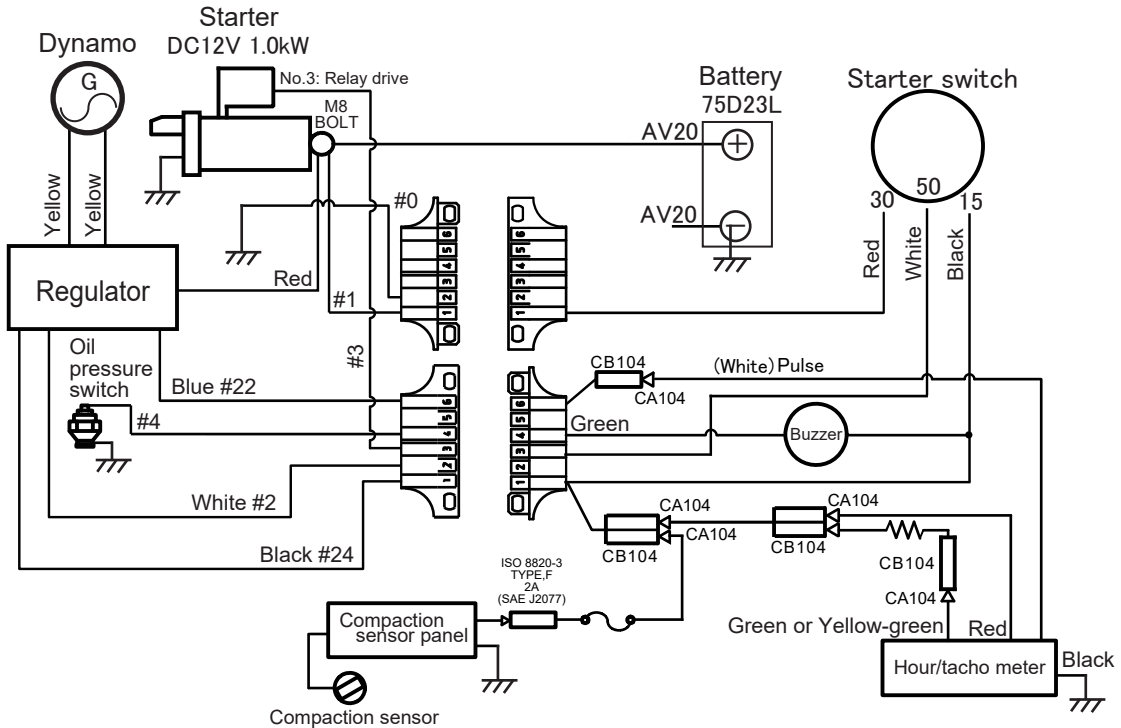

MVH-508GHS

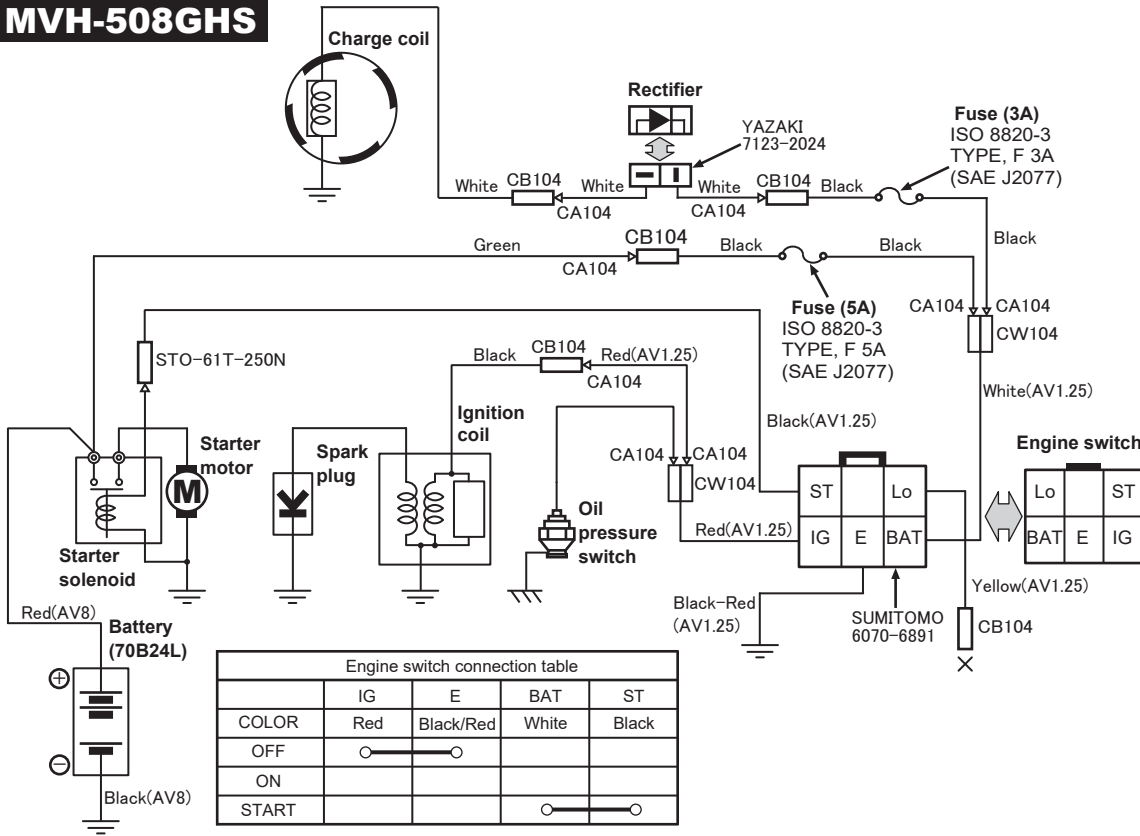

MVH-508GHS PAS

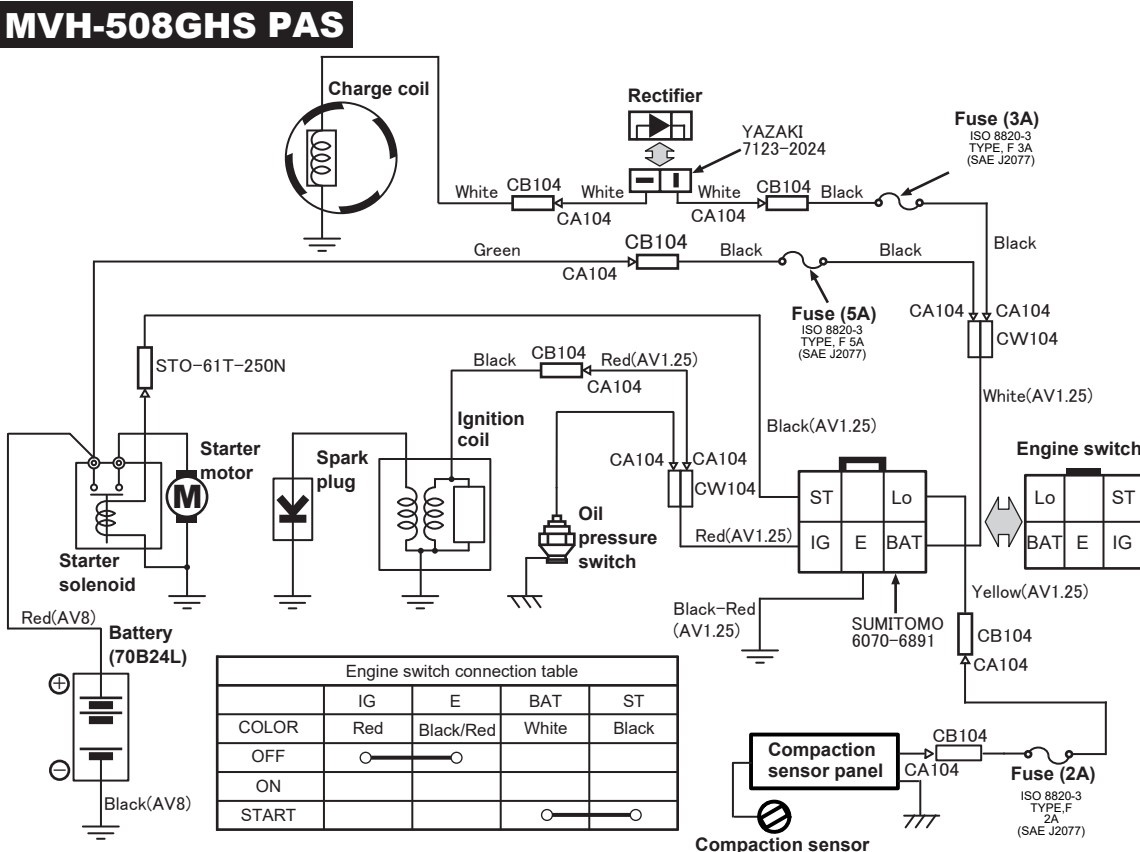

Mikasa