



PLATE COMPACTOR

MVC-40G ***MVC-50GB***

INSTRUCTION MANUAL



Contents of “Declaration of Conformity”

Please refer the
EC DECLARATION OF CONFORMITY
in this manual as well.

We thank you for selecting
Mikasa Plate Compactor. For
your safe and proper operation,
please read this manual and be
always sure to keep it ready for
reference.

Original



MIKASA SANGYO CO.,LTD.

402-04812

1) DECLARATION OF CONFORMITY

2) Manufacturer's name and address.	Mikasa Sangyo Co., Ltd. 4-3, Sarugaku-cho 1 chome, Chiyoda-ku, Tokyo101-0064, Japan					
3) Name and address of the person who keeps the technical documentation.	Yoshiharu Nishimaki, engineer R. & D. Division, Mikasa Sangyo Co., Ltd. Shiraoka-city, Saitama, Japan					
4) Type: Vibratory Plates						
5) model	MVC-40G	MVC-50GB	MVH-50GBH			
6) Equipment item number	352062, 352064, 352065, 352068, 352069, 352070, 352073	352040, 352043, 352044, 352045, 352049, 352050, 352055, 352056, 352057, 352058, 352060	352039, 352059			
7) Serial number	For serial number, please refer it on front page.					
8) power source cont. output <max.output>	Robin EH09 1.5kW <2.1kW>	Robin EX13 2.2kW <3.2kW>	Honda GX120 2.1kW <2.6kW>			
9) Measured sound power level(dB)	97	101	102			
10) Guaranteed sound power level(dB)	105	105	105			
11) Max. Sound pressure level(dB)	84	91	93			
12) Conformity assessment according to Annex:	VIII (Full Quality Assurance procedure)					
13) Name and address of the Notified Body	Société Nationale de Certification et d'Homologation (SNCH) 11, route de Luxembourg L-5230 Sandweiler LUXEMBOURG					
14) Related Directive	Directive 2000/14/EC and, to be followed by Directive 2005/88/EC , relating to the noise emission in the environment by equipment for use outdoors.					
15) Declaration	The equipment referred in this document, fulfills with all the requirements of Directive 2000/14/EC					
16) Other related Community Directives	2006/42/EC, 2005/88/EC, 2004/108/EC, 2002/88/EC(2004/26/EC) EN500-1, EN500-4					
17) EC Conformity Certificate No:	SNCH*2000/14*2005/88*0472*03					
18) Place and date of the declaration	Tokyo, Japan July, 2013 Signed by:  _____ Keiichi YOSHIDA Director, Product Control Division Mikasa Sangyo Co., Ltd.					

TABLE of CONTENTS

1.	Preface	1
2.	Applications, Warnings, Structure and Power Transmission	1
3.	Warning Symbols	2
4.	Safety Precautions	2
4.1	General precautions	2
4.2	Refueling precautions	2
4.3	Location and ventilation precautions	3
4.4	Precautions before starting	3
4.5	Precautions during work	3
4.6	Lifting precautions	3
4.7	Transportation and Storage precautions	3
4.8	Maintenance precautions	4
4.9	Labeling Position	5
4.10	Description of symbols used warning labels	6
5.	Specifications	7
5.1	Machine specifications	7
5.2	Engine specifications	7
6.	Appearance	8
6.1	Overall Dimensions	8
6.2	Control Unit Positions and Names	9
7.	Inspection Before Operation	10
8.	Operation	11
8.1	Starting	11
8.2	Operation	12
9.	Stopping the machine	13
10.	Transportation	13
10.1	Loading and Unloading	13
10.2	Transportation precautions	13
11.	Storage	13
12.	Regular Check and Adjustments	14
12.1	Inspection and maintenance schedule table	14
12.2	Changing the engine oil	15
12.3	Cleaning the air cleaner	15
12.4	Checking/Changing V-belt and Clutch	15
12.5	Inspection and Change of vibrator oil	15
13.	Troubleshooting	16

1. Preface

- This operation manual describes the proper operation, basic inspection and maintenance procedures of the plate compactor. Please read this operation manual before use in order to maximize the excellent performance of this machine and make your work more efficient and effective.
- After reading the manual, please keep it in a handy location for easy reference.
- For the handling the engine, please refer to the separate engine operation manual.
- For inquiries about repair parts, parts lists, service manuals, and repairs, please contact the store where you purchased the product, our sales office, or the Mikasa Parts Service Center. For parts lists, please visit our homepage at: <http://www.mikasas.com/> where you can access Mikasa WEB parts lists.

The illustrations in this manual might slightly differ in part from the machine you actually purchased due to design changes.

2. Applications, Warnings, Structure and Power Transmission

Applications

Plate compactor is the machine that compacts the ground and it intends to make the surface smooth, by transmitting vibration through vibrating plate, which power generated from single rotor in vibrator case.

This machine is suitable for making the ground surface smooth, such as leveling the soil and beaching, finishing the asphalt paving.

Warning about incorrect applications and techniques

This machine is hard to move forward on a soil with much water (especially clay soil). It is not suitable for such application. This machine is difficult to level a ground include big stones due to insufficient compacting force. Plate compactor is mainly applied for compacting surface smooth and it is not effective for jobs that requires heavy compaction. In case of compacting ground deeply into lower layer, it is recommended to use Tamping Rammer, Vibro Compactor or Vibration Roller of which compacting force is rather effective. Please use this compactor for compacting surface on soil, sediment, beaching and asphalt. It is not recommended for use this machine for the other applications.

Structure

The upper part is made up of Power source, Handle, Belt Cover, Water Tank for sprinkling and Guard Hook which are fixed by Engine Base. The Engine base is fixed on Vibrating Plate by Shock Absorbing Rubber. The lower part is made up of Vibrating Plate and Vibrator Unit that has an Eccentric rotary shaft built in. The power source is transmitted from the centrifugal clutch on engine output shaft to the Eccentric rotary shaft through V-belt.

Power transmission

Air-cooled Single Cylinder Engine is amounted as power source and Centrifugal Clutch is fixed on engine output shaft.





Centrifugal Clutch engages by running up the engine and engine R.P.M. is reduced to suitable number for compacting. The rotation of engine is transmitted from V-pulley integrated with Clutch Drum to Vibrator Pulley through V-belt.

Vibrator Pulley rotates Eccentric Rotor Shaft that is contained in Vibrator Case. The generated vibration created from Eccentric Rotor is transmitted to Vibrating Plate.

Vibration of Vibrating Plate carries the machine forward; the vibration with the weight of the machine makes the compaction of the ground possible.









3. Warning Symbols

The triangle marks () used in this manual and on the decals on the machine are warning symbols. Please follow these precautions.



	Warning symbols indicating personnel hazards
	Extremely hazardous. If the warning is not followed, it is likely to result in serious injury or death.
	Hazardous. If the warning is not followed, it is likely to result in serious injury or death.
	Potential hazard. If the warning is not followed, it may result in injury.
Precautions (without  mark) If the warning is not followed, it may result in property damage.	

4. Safety Precautions



4.1 General precautions

	<ul style="list-style-type: none"> ● Do not operate the machine, <ul style="list-style-type: none"> ○ If you do not feel well due to overwork or illness. ○ If you are taking any medicine. ○ If you are under the influence of alcohol. 	 
	<ul style="list-style-type: none"> ● Read this manual carefully and handle the machine as described to ensure safe work. ● For details about the engine, refer to the separate manual for the engine. ● Make sure you understand the structure of the machine well. ● For safe work, always wear protective gear (helmets, safety shoes, ear plugs, etc.) and work in appropriate clothes. ● Always check the machine before your work to make sure it is in normal condition. ● Decals on the machine (operation method labels, warning labels, etc.) are very important for your safety. Keep the machine clean so that the decals can be read all the time. Replace a decal if it becomes illegible. ● Before performing maintenance work, be sure to turn the engine off. ● It is very dangerous if children come into close contact with the machine. Have the utmost concern about how and where to store the machine. In particular, for an engine with a cell, always remove the starter key and keep it in a designated place. ● Before inspection and maintenance work, stop the engine, and do your work on a flat surface area. If a cell is attached, remove the battery wiring before your work. ● Mikasa does not accept any responsibility for accidents caused by remodeling or rework done on the machine. 	   

4.2 Refueling precautions

	<ul style="list-style-type: none"> ● When adding fuel, <ul style="list-style-type: none"> ○ Make sure you work in a well ventilated location. ○ Make sure the engine is stopped and wait until it cools down. ○ Take the machine to a clear flat location without any combustibles nearby. Be careful not to spill the fuel. Wipe well if any spill occurs. ● Do not fill to the rim due to potential spillage. ● After adding the fuel, tightly close the tank cap. 	 
---	---	---



4.3 Location and Ventilation precautions

	<ul style="list-style-type: none"> ● Do not run the machine in an unventilated location, such as indoors or inside a tunnel. The exhaust gas from the engine contains toxic gases such as carbon monoxide and is very hazardous. ● Do not operate the machine near open flames. 	
---	---	---

4.4 Precautions before starting

	<ul style="list-style-type: none"> ● Check each part to see if it is tightened properly. Vibration causes loosening of bolts, which results in unexpected serious malfunctions of the machine. Tighten the bolts securely. 	
---	---	--

4.5 Precautions during work

	<ul style="list-style-type: none"> ● Before starting the machine, make sure it is safe to start by checking your surroundings for people and objects. ● Always pay attention to your footing. Work in an area where you can maintain a good balance of the machine and a safe comfortable posture. ● The engine and muffler become very hot. Do not touch immediately after the machine stops because they are still very hot. ● If you notice deterioration of machine operation during your work, stop your work immediately. ● Before moving away from the machine, be sure to turn the engine off. Also when the machine is transported, stop the engine and close the fuel cock. 	 
---	--	---

4.6 Lifting precautions

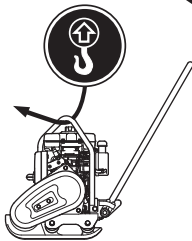

For unloading using a crane, a licensed crane operator is needed. An operator should be qualified for crane and hooking work.

	<ul style="list-style-type: none"> ● Before lifting, check the machine parts (especially the hook and anti-vibration rubber) for any damage and loosened or missing bolts. ● Stop the engine and shut the fuel cock while lifting. ● Use a wire rope with sufficient strength. ● For lifting, use only one point hoisting hook, and do not lift at any other part. ● When the machine is hoisted, never let people or animals come underneath. ● For safety reasons, do not lift to a height that is higher than necessary. 	
---	---	---

4.7 Transportation and Storage precautions

	<ul style="list-style-type: none"> ● Stop the engine during transportation. ● Transport after the engine and the machine are cooled down. ● Always drain the fuel before transporting. ● Securely fix the machine to prevent it from moving or falling during transportation. 	
---	---	--

4.8 Maintenance precautions

	<ul style="list-style-type: none"> ● Appropriate maintenance is required to ensure safe and efficient operation of the machine. Always pay attention to the machine's condition and keep it in good condition. Pay special attention to the parts used for lifting, if they are not maintained properly, it might result in a serious accident. ● Start maintenance work after the machine has cooled down completely. The muffler, in particular, becomes very hot, and there is a danger of burn. The engine, engine oil and vibrator also become very hot. Be careful not to get burned. 	
	<ul style="list-style-type: none"> ● Always stop the engine before inspection and adjustment. If you are caught in a rotating part, serious injury might occur. ● After maintenance work, check the security parts to see if they are securely installed. Special attention should be paid when checking bolts and nuts. ● If disassembly is involved in maintenance, refer to the maintenance instruction manual to make your work safe. 	

4.9 Labeling Position

MVC-40G/GB

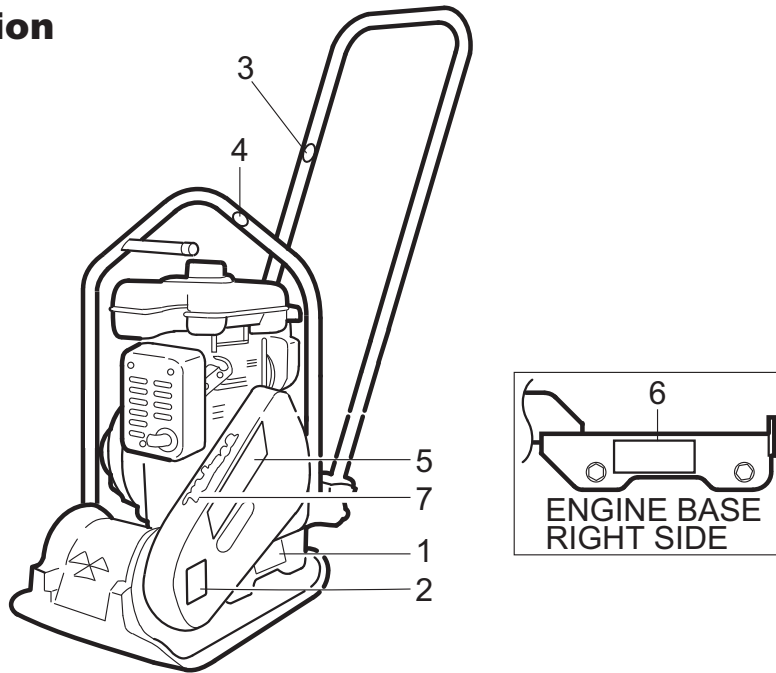

MVC-50GB

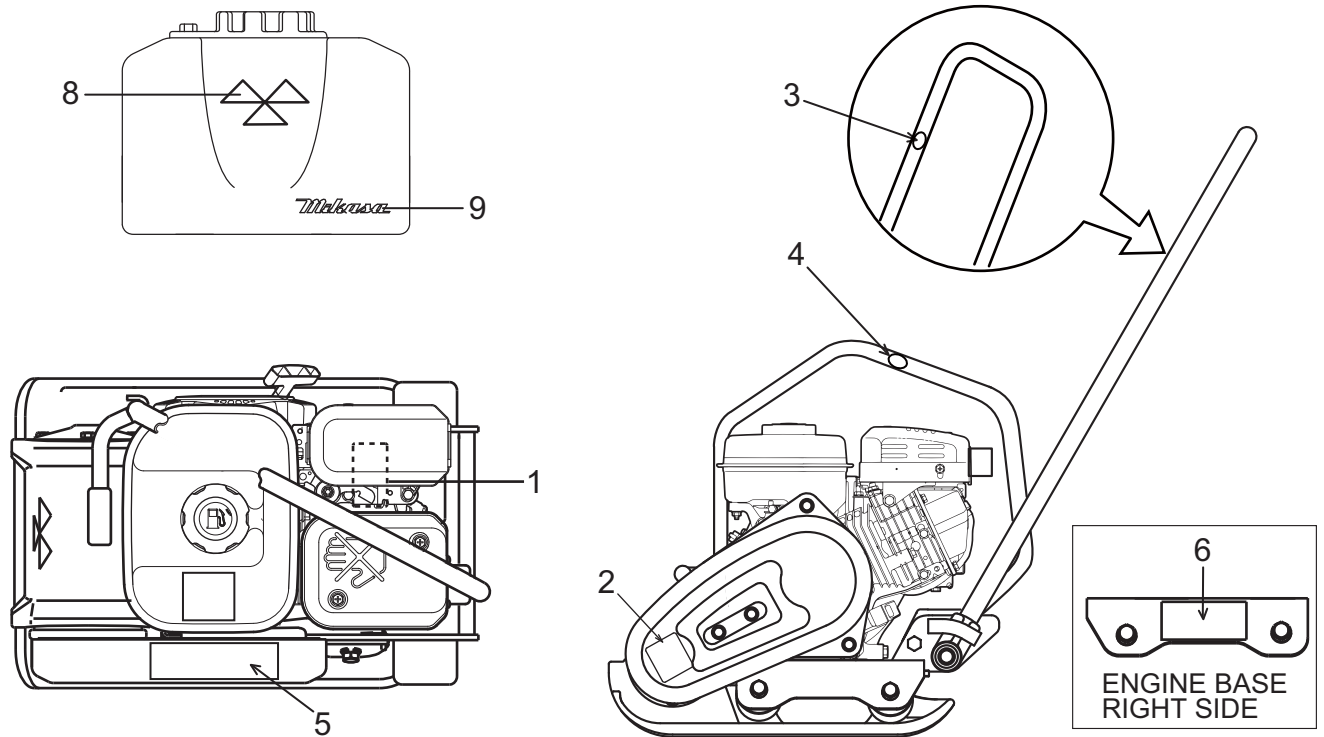







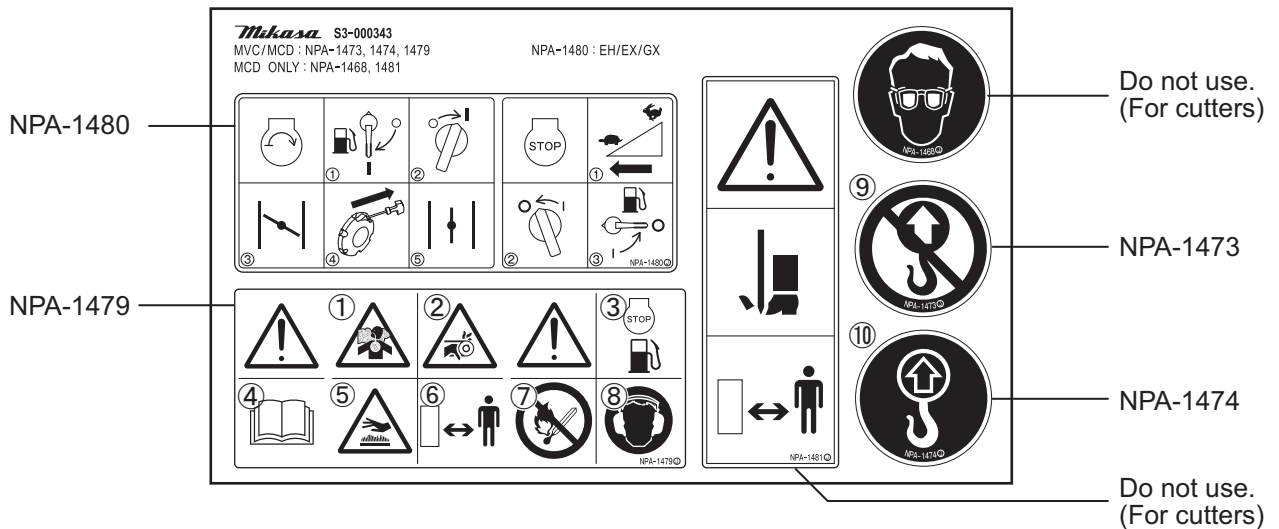

REF No.	PART No.	PART NAME	Q' TY	LABEL No.	REMARK
1	—	PLATE, SERIAL NO. / EU	1	—	
2	9202-10330	DECAL, EC NOISE REQ. LWA105	1	NPA-1033	
3	9209-00090	DECAL, DO NOT LIFTING	1	NPA-1473	
4	9209-00090	DECAL, LIFTING POSITION	1	NPA-1474	
5	9209-00090	DECAL, CAUTION ICONS	1	NPA-1479	Warnig labels
6	9209-00090	DECAL, ENGINE HANDLING /GS	1	NPA-1480	Starting, and stopping
7	9201-09530	DECAL, MIKASA(125MM)YELLOW	1	NP-953	40G
8	9201-00920	DECAL, MIKASAMARK	1	NP-92	50GB/ WATER TANK
9	9201-05070	DECAL, MIKASA MARK 125MM	1	NP-507	50GB/ WATER TANK

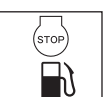
4-10. Descriptions of symbols used on warning labels

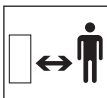
P/N 9209-00090 DECAL, SET /MVC, MCD /EXP,EU



- | | |
|---|---|
| <p>①  Danger: poisonous exhaust gas
Carbon monoxide poisoning may occur if the exhaust gas is inhaled. Do not operate the machine in a poorly ventilated area.</p> <p>②  Be careful not to get caught in the rotating parts.
During operation, be careful not to have your fingers, body, clothes, etc. come in contact with the rotating parts such as the V-belt and clutch.</p> <p>③  Refueling Hazard.
Don't fill the fuel tank while the engine is running or hot.</p> <p>④  Read the manual carefully.
Always read the operation manual and have good understanding of operation before your work.</p> <p>⑤  Be careful not to get burned.
Accidental burn may occur if you touch the hot parts (engine, muffler, etc.) during operation or immediately after the machine stops.</p> | <p>⑥  Be careful not to approach danger source.
During operation, Be careful not to approach hot parts and rotating parts.</p> <p>⑦  Fire hazard
Stop the engine when refueling. Fire may occur if a flame is near the tank fuel port.</p> <p>⑧  Danger of hearing damage caused by noise
Always use ear plugs while operating the machine.</p> <p>⑨  Lifting by the handle is prohibited.
Due to a falling risk, do not lift the machine by the handle.</p> <p>⑩  Lifting position.
For lifting, use only one point hoisting hook, and do not lift at any other part.</p> |
|---|---|

Starting, and stopping

P/N 9209-00090 DECAL, SET /MVC, MCD /EXP, EU

START

- Open Fuel Cock to start
- Turn Stop Switch to "I"(ON) position
- Close Choke Lever
- Pull Recoil Starter to start
- Return Choke Lever to open

STOP

- Return Throttle Lever fully until "O"(OFF) position to stop work
- After cooling down enough, stop the engine to move Stop Switch to "O"(OFF) position
- Close Fuel Cock at the end

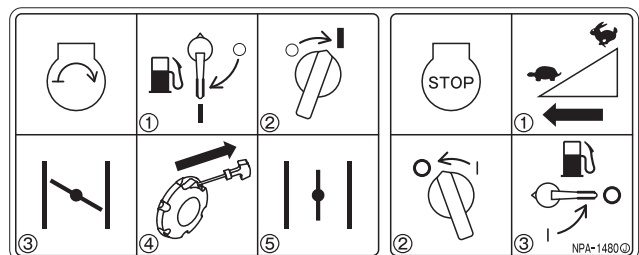

5. Specifications

5.1 Machine specifications

Model	MVC-40G		MVC-40GB		MVC-50G
	STD	Folding Handle	STD	Folding Handle	STD
Engine model	Robin EH09-2F	←	←	←	Robin EH12-2D
Overall Length mm	855	865	855	865	865
Overall Width mm	290	←	290	←	345
Overall Height mm	920	865	920	865	920
Plate Size (W X L) mm	290 x 420	←	290 x 420	←	345 x 460
Operating Weight kg	46	47	46	47	59
Travelling Speed m/min	25	←	25	←	25
Vibrating Frequency Hz [vpm]	103 [6200]	←	103 [6200]	←	97 [5800]
Centrifugal Force kN [kgf]	7.2 [730]	←	7.2 [730]	←	9.8 [1000]
Vibrating unit	SAE 10W-30	←	SAE 10W-30	←	SAE 10W-30
Lubrication oil in vibration case	300 cc	←	300 cc	←	300 cc
Water tank capacity	_____	_____	_____	_____	_____
V-Belt Size	RPF3270	←	RPF3270	←	RPF3270

Model	MVC-50GB				MVC-50GBH
	STD Handle		Folding Handle		STD Handle
	STD	With Water Tank	STD	With Water Tank	
Engine model	Robin EX13	←	←	←	Honda GX120
Overall Length mm	865	925	880	940	880
Overall Width mm	345	←	←	←	345
Overall Height mm	920	←	850	←	850
Plate Size (W X L) mm	345 x 460	←	←	←	345 x 460
Operating Weight kg	59	66	60	67	58
Travelling Speed m/min	25	←	←	←	25
Vibrating Frequency Hz [vpm]	97 [5800]	←	←	←	97 [5800]
Centrifugal Force kN [kgf]	9.8 [1000]	←	←	←	9.8 [1000]
Vibrating unit	SAE 10W-30	←	←	←	SAE 10W-30
Lubrication oil in vibration case	300 cc	←	←	←	300 cc
Water tank capacity	_____	8.5 L	_____	8.5 L	_____
V-Belt Size	RPF3270	←	←	←	RPF3270

5.2 Engine specifications

Manufacturer	Robin	Robin	Robin	Honda
Model	EH09-2F (petrol)	EH12-2D (petrol)	EX13 (petrol)	GX120 (petrol)
Max. Output	2.1kW(2.8PS) /4200min ⁻¹	2.6kW(3.5PS) /3600min ⁻¹	3.2kW(4.3PS) /4000min ⁻¹	2.6kW(3.5PS) /3600min ⁻¹
Fuel Tank Capacity liters	1.5	3.6	2.7	2.5
Lubricant capacity cc	300	600	600	600
Starting system	Recoil starting	Recoil starting	Recoil starting	Recoil starting
Set R.P.M rpm	4000	3600	3600	3600

(The specifications may be changed without notice)

6. Appearance

6.1 Overall Dimensions

6.1.1 MVC-40G/GB

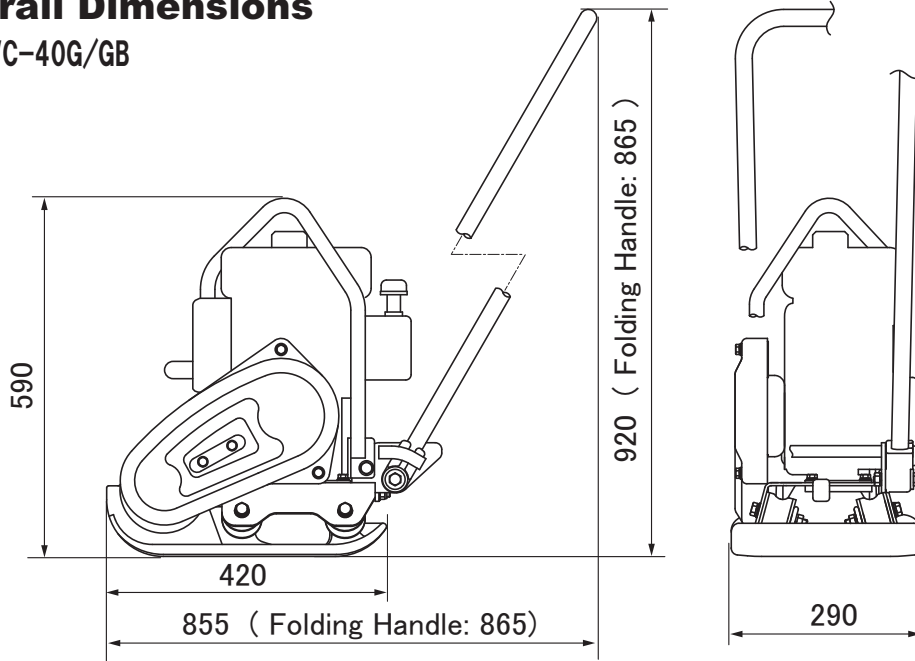

6.1.2 MVC-50GB

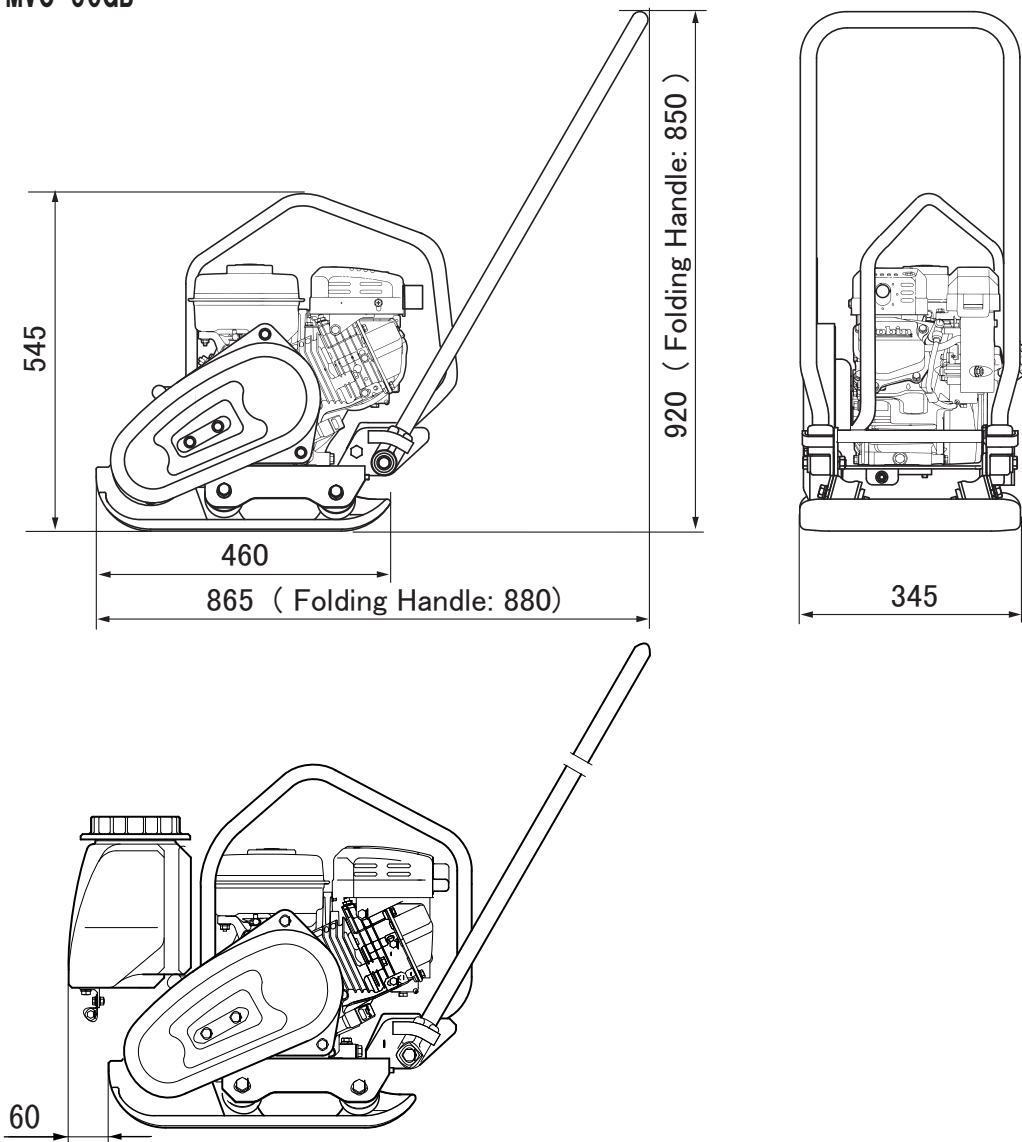

Dimensions may change without notice.

6.2 Control Unit Positions and Names

MVC-40G/GB

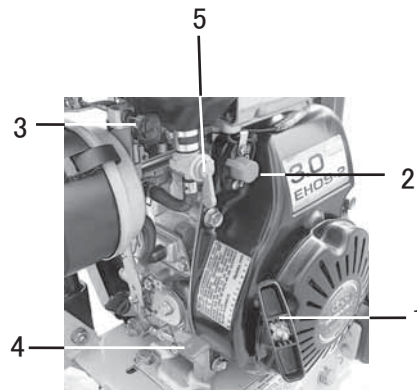
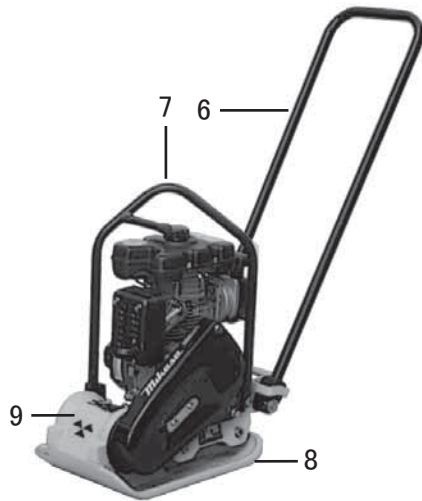

1. Starter Grip
2. Engine ON/OFF Switch
3. Choke Lever
4. Speed Control Lever
5. Fuel Cock
6. Handle Bar
7. Folding Handle
8. Lifting Hook
9. Vibrating Plate
10. Vibration Case
11. Water Shut-Off Valve

MVC-50GB

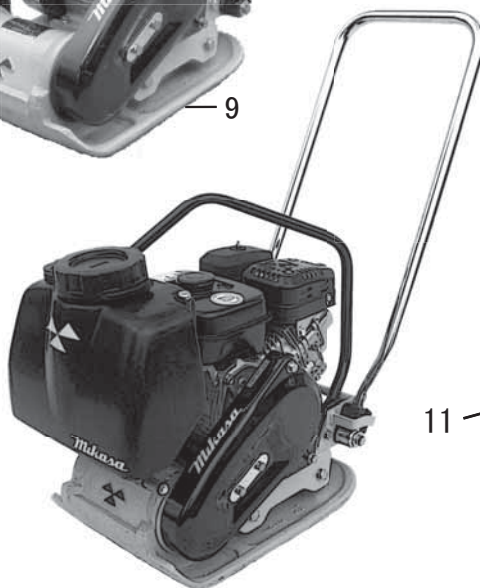
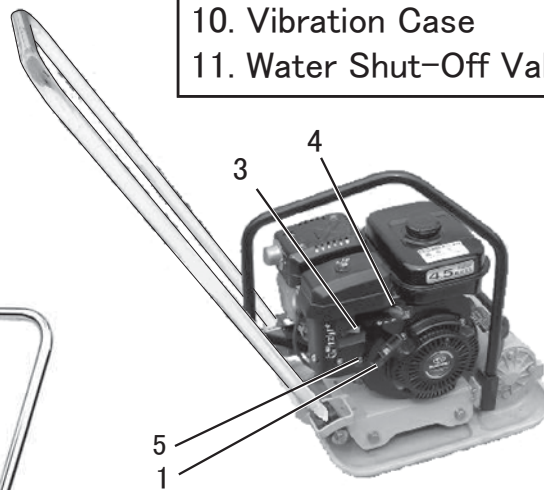
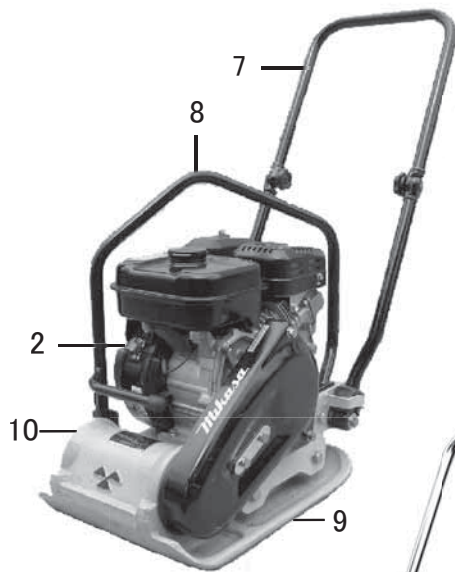

7. Inspection Before Operation

⚠ DANGER

Conduct inspection while the engine is stopped. If you get caught in the rotating parts, you may suffer serious damage. Conduct inspection after making this machine level and checking that the body does not move.

Refer to "Regular Check and Adjustments" on page 14 for the inspection points before starting operation.

- 1 Clean each part of the machine well to maintain dirt and dust-free condition. Pay special attention to the soil adhered to the bottom of the vibrating plate, engine cooling air inlet, and the carburetor and air cleaner area to keep those parts clean.
- 2 Check each part for any looseness of bolts. Vibration causes bolts & nuts to loosen, which might result in unexpected accident or malfunction.
- 3 Inspect the guard hook, belt cover and anti-vibration rubber, as well as to check the function of speed adjustment wire and speed adjusting lever.
- 4 Check V-belt tension. The belt should have about 10 – 15mm of flexibility when pushed strongly with a finger at the mid-point between the axes. If V-belt is loosened, power is not transmitted connectively, which reduces compacting force and shortens the life of V-belt. In addition, the generated compaction force will lead to irregular vibrations when the engine revolutions are increased, and may result in a machine failure.
- 5 Set the engine on a level surface to check the oil level. If the oil level is low, add oil. Use the following engine oil.(Fig 1)

Quality: Gasoline engine oil, Grade SE or above
Viscosity: SAE No. 30 at 20°C and above (summer)
SAE10W-30

Temperature	Use oil
More than 25	SAE#30
10 ~ 25	SAE#30, #20
10 ~ 0	SAE#20
Less than 0	SAE#10

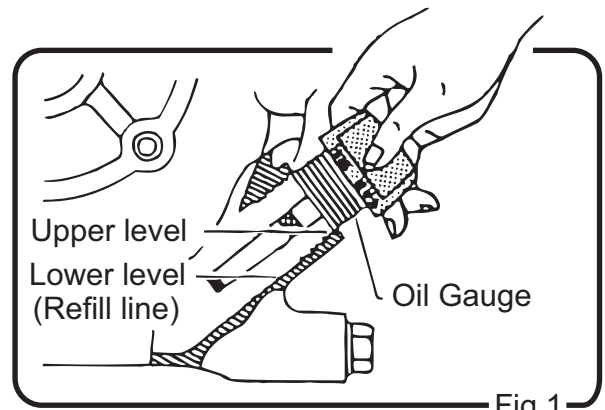

Fig.1

- 6 Set the machine on a level surface, then remove the oil gauge of the vibrator. Check the oil gauge to see if the oil is at the specified level. Use engine oil SAE10W-30 as lubrication oil. Recommended oil quantity for MVC-40G/50G is 300cc. Remove the oil plug in Vibrator Assembly and check the oil level. Make sure the oil quantity is set at level of plug hole for checking. Every month or every 200 hours of operation, replace the oil.(Fig 2)

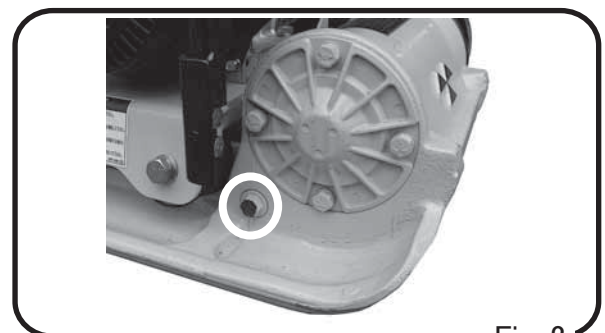

Fig. 2

- 7 A regular grade gasoline should be used in the engine. When filling the fuel tank, make sure the fuel filter is used.



Never refuel this machine while leaving the engine running. There is danger of fire.



Never smoke, or put other flames close to this machine while refueling. Serious hazards such as burns and fire may result.



Choose a place free from flammable substances for refueling. Be careful not to spill fuel. In case fuel should be spilled, wipe off the spilled fuel completely.



8. Operation

8.1 Starting



The engine exhaust gas contains carbon dioxide and is very dangerous.

Do not use this machine where ventilation is poor.

Gasoline engine

- 1 Turn the lever of the fuel cock downward and feed fuel. (Figs. 3-1, 3-2, 3-3)

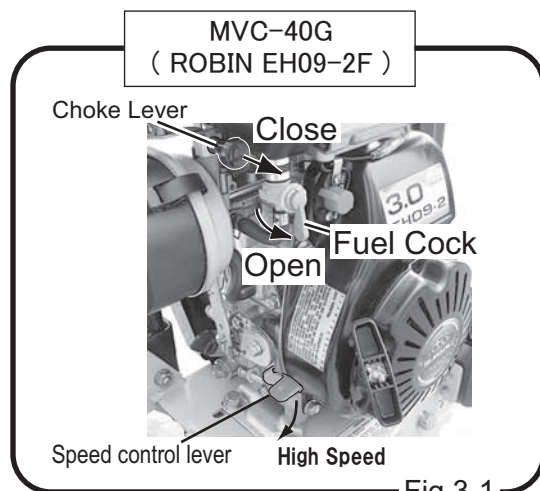

Fig.3-1

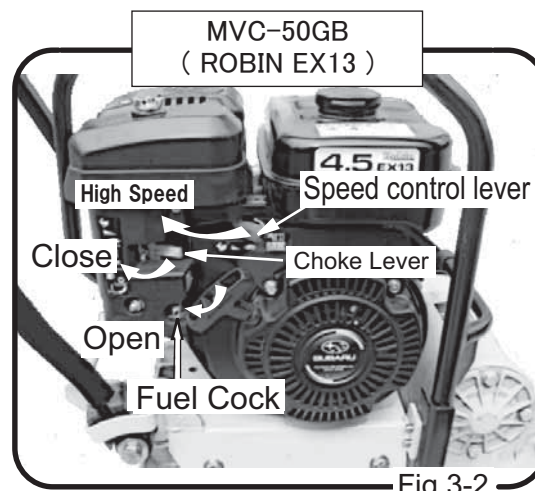

Fig.3-2

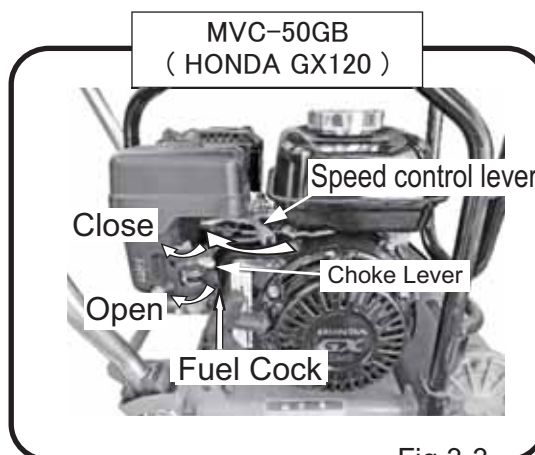

Fig.3-3

- 2 Turn the stop switch to "ON (I)" position. (Fig.4)
- 3 Open the speed control lever half. (Fig.3-1, 3-2)

When it is cold or the engine does not start easily, close the choke lever. (Figs. 3-1 , 3-2)

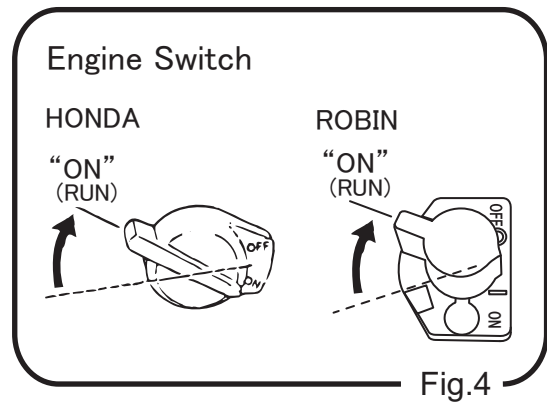

Fig.4

- 4 Grip the starting knob of the recoil starter. When you pull the rope a little, you will feel some resistance. Then pull it at a stroke. Be careful not to pull the rope too strongly, or the rope may break or come off. (Fig.5)
- 5 When the engine has started, return the speed control lever to the low speed position immediately. Listening to the sound of the explosion, return the choke lever gradually to the fully open condition. (Fig.3-1 , 3-2)

After the start, be sure to conduct the warm-up operation at low speed for 2-5 minutes. This is particularly important when it is cold. During this time, check for any abnormalities such as gas leakage.

Note: If you leave the speed control lever half-open, the centrifugal clutch turns into a slipped state. This may cause a failure of the centrifugal clutch, and also cause abnormal vibration of this machine, which is very dangerous. So, as soon as the engine has started, return the speed control lever to the low-speed position.

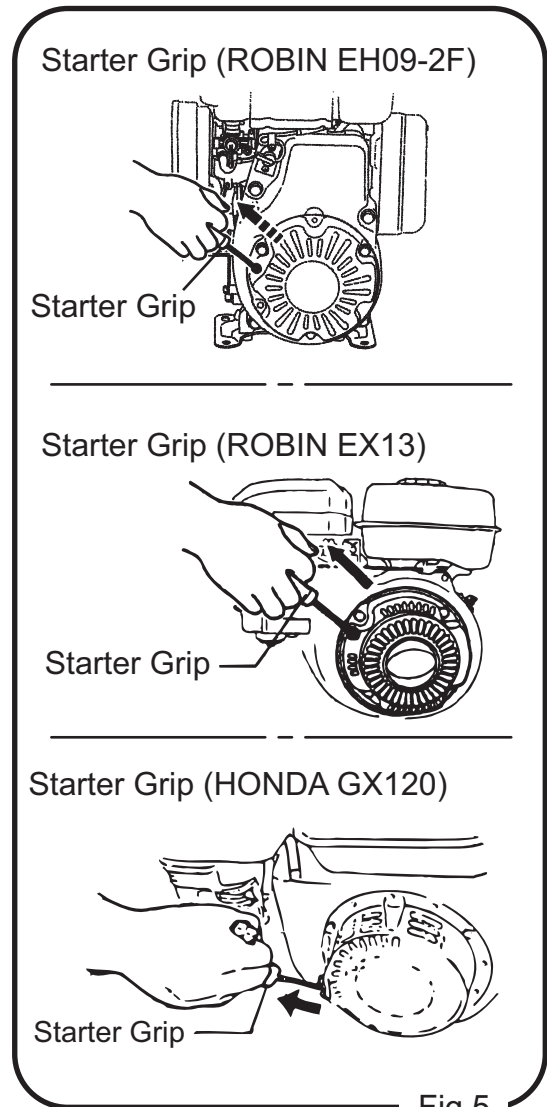

Fig.5

8.2 Operation

- 1 If you open the speed control lever at a stroke, this machine starts vibration and moves forward. If you open it slowly, the clutch may slip, so open the speed control lever at a stroke without hesitation. (Figs. 3-1 , 3-2)
- 2 When this machine is used on cohesive soils, the vibrating plate does not move over the ground easily and the travel speed becomes slow. Check that clay is not adhering to the bottom of the vibration plate. The compaction force of this machine does not act effectively on cohesive soils or soils of a high moisture ratio. In this case, use other machine such as a rammer, or dry the soils and decrease the moisture ratio.
- 3 When you stop the operation, return the speed control lever at a stroke.

9. Stopping the machine

- 1 When you finish the work and stop the engine, return the speed control lever to the low speed position, and keep the engine running at low speed for 3-5minutes. When the temperature of the engine has decreased, stop the engine.

CAUTION

If you stop the engine while it is still hot, this machine will be affected adversely, causing, for example, burning of the oil film on the inner wall of the cylinder, which may accelerate wear of the inner wall of the cylinder. This may result in a shorter life of this machine, or cause unexpected failure.

- 2 Turn the engine switch to the OFF position, then the engine stops. (Fig. 6)
Close the lever of the fuel cock. (Fig. 3-1, 3-2, 3-3)

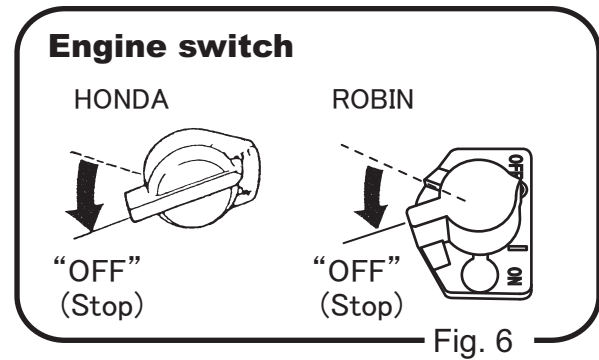

10 Transportation

WARNING	<ul style="list-style-type: none"> ● Make sure there is no breakage of guard frame and anti-vibration rubber nor loosened or missing bolts. ● Always stop the engine when lifting. ● Use an intact wire rope without any deformation with sufficient strength. ● Slowly lift upward without applying any impact. Never let people or animals go under the lifted machine. ● For safety reasons, do not lift to a height that is higher than necessary.
----------------	---

10.1 Loading and Unloading

For loading and unloading using a crane, an operator qualified for cranes and hooking works is needed.

- 1 Use a crane for loading and unloading the machine.
- 2 Designate a person to guide the loading and unloading, and always work under the instruction of that person.
- 3 When lifting, always use a special hook on the guard frame. (Fig. 7)
Never lift by hooking the handle.

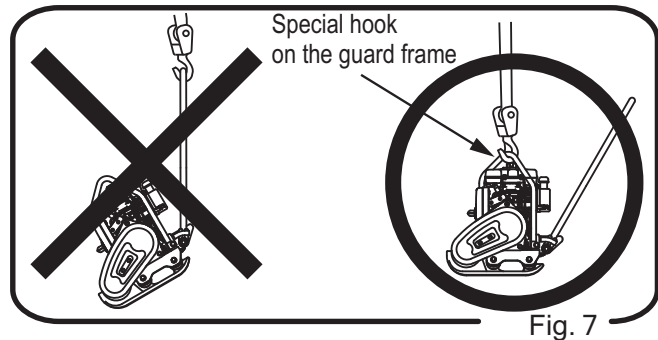

10.2 Transportation precautions

WARNING	<ul style="list-style-type: none"> ● Stop the engine when the machine is transported. ● Always drain the fuel before transportation. ● Fix the machine securely to prevent the machine from moving or falling.
----------------	---

11 Storage

- 1 Wash with water to remove any dust and dirt from all parts of the machine.
- 2 Store in a dry area away from direct sunlight after putting the cover over the machine to prevent dust and dirt buildup.
(When storing this machine for an extended period of time)
- 3 Drain the fuel from the fuel tank, fuel pipe, and carburetor completely.
- 4 Conduct fueling and replenishment/change of oil without omission. Remove the spark plug, put a few drops of engine oil into the cylinder, and rotate the engine manually for spreading the oil inside sufficiently.
- 5 Securely cover the air cleaner and muffler air inlets and exhaust port.
- 6 Do not leave the machine outdoors. Keep it indoors.
- 7 Don not store this machine by laying it on its side (or backward).

12. Regular Check and Adjustments

12.1 Inspection and maintenance schedule table

Check frequency	Check parts	Check items	Oils
Daily (before starting)	Appearance	Flaw, deformation	
	Fuel tank	Leakage	
	Fuel system	Leakage	
	Engine oil	Leakage, oil level, dirt	Engine oil
	Shock absorber	Crack, damage, wear	
	Vibrator oil	Leakage	Engine oil
	Air cleaner	Dust on sponge	
	Guard frame	Breakage, flaw, loosened or missing bolts and nuts	
	Back and forth motion lever operation	Operation check, play	
	Bolts and nuts	Looseness, missing	
Every 20 hours	Engine oil	Replace only after the first 20 hours	Engine oil
Every 100 hours	Engine oil	Change	Engine oil
	Engine oil filter	Washing	
	Vibrator oil	Leakage, oil level, dirt	Engine oil
Every 200 hours	V-belt for vibrator	Flaw, tension	
	Clutch	Dirt, flaw, wear	
Every 300 hours	Vibrator oil	Change	Engine oil
	Fuel filter	Change	
Every 2 years	Fuel pipes	Change	
Irregular	Air cleaner element	Change	

For details about the check and maintenance of the engine, please refer to the attached engine operation manual.

Caution:

The above table shows the check frequency for standard condition.

The check frequency may vary depending on the condition in which the machine is used.

For check of bolt and nut looseness and tightening, please see the following tightening torque list.

Tightening torque list (unit: kgf-cm, 1kgf-cm=9.80665N-cm)

		Thread diameter							
		6mm	8mm	10mm	12mm	14mm	16mm	18mm	20mm
Material	4T(SS41)	70	150	300	500	750	1,100	1,400	2,000
	6-8T(S45C)	100	250	500	800	1,300	2,000	2,700	3,800
	11T(SCM3)	150	400	800	1,200	2,000	2,900	4,200	5,600
	When the mating material is aluminum.	100	300~350	650~700	(Bolts used on the machine are all right-hand thread.)				

12.2 Changing the engine oil

Perform the first engine oil change after 20 hours of operation, then change at every 100 hours.

12.3 Cleaning the air cleaner

When the air cleaner element becomes dirty, the engine does not start smoothly, and sufficient output can not be obtained. Machine operation will be affected and the engine life will be shortened greatly. Do not forget to clean the element. (For details, please see the separate engine operation manual.) If the element can not be cleaned, replace it with a new one.

12.4 Checking/Changing V-belt and Clutch

1 Checking V-belt

Remove the belt cover and check that V-belt is properly stretched every 200 hours. Press on the portion midway between the two shafts with your fingers strongly. The belt is properly stretched if that portion bows by about 10-15 mm.

2 Checking the clutch

Inspect the clutch concurrently with the inspection of V-belt. Check visually for burning of each clutch-shoe. Check for wear the lining shoe or the like in the operation check. If the shoe wears, power transmission is not performed properly and the clutch slips. Check wear of and damage to the V-groove. If the V-groove is stained, clean it thoroughly.

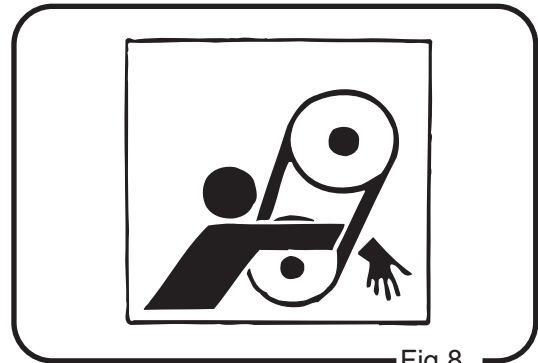

Fig.8



Always stop the engine before inspection and adjustment. If you are caught in a rotating part, serious injury might occur.



When the vibration weakens during operation, or this machine does not vibrate at all though the engine rotates normally, conduct the inspection or change of the V-belt and clutch without regard to the regular inspection of every 200 hours.

12.5 Inspection and Change of vibrator oil

Make this machine level, and remove the oil level plug off the vibrator. Check that vibrator oil is provided up to the mouth level. The oil level plug is on the right side of the vibrator case (opposite to the belt side). (Refer to Fig.1 on page 10.)

Use the engine oil #10W-30 for vibrator oil. Refer to page 7 for the amount. Drain the vibrator oil completely by removing the plug and tilting the body once a month or every 200 hours' operation. Replace with new oil.

13. Troubleshooting

1. Gasoline engine

(1) Starting problem

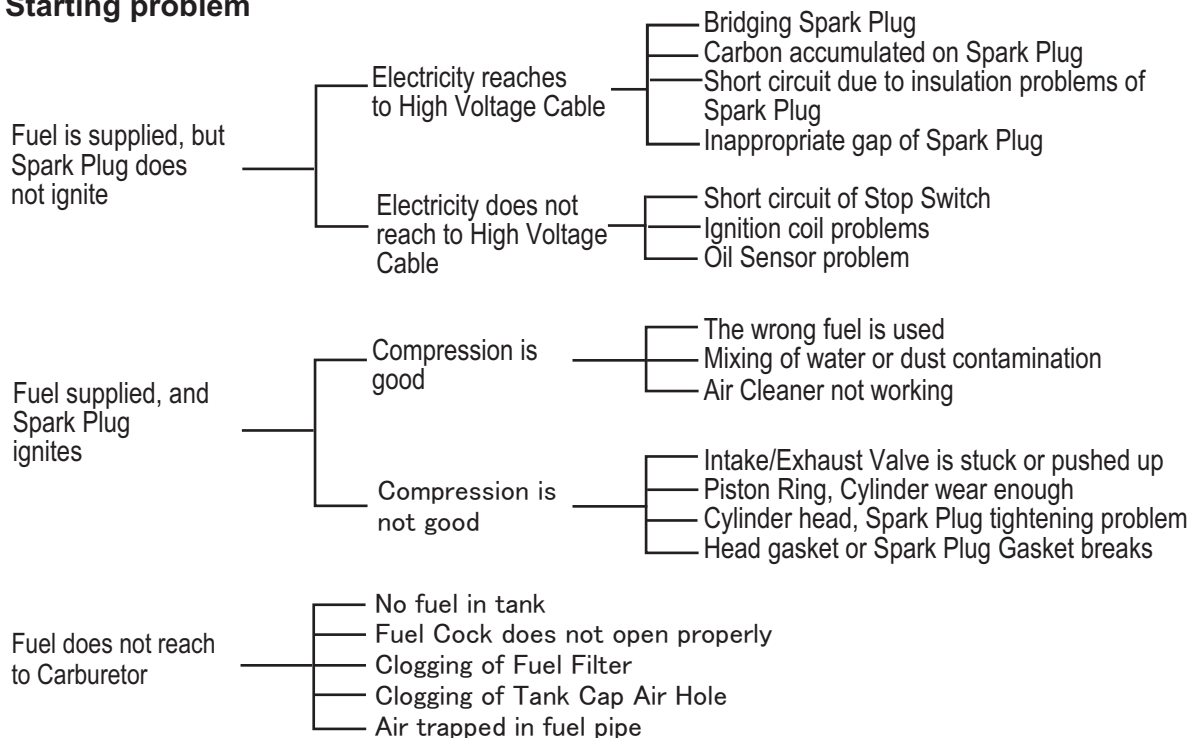

(2) Operation problem

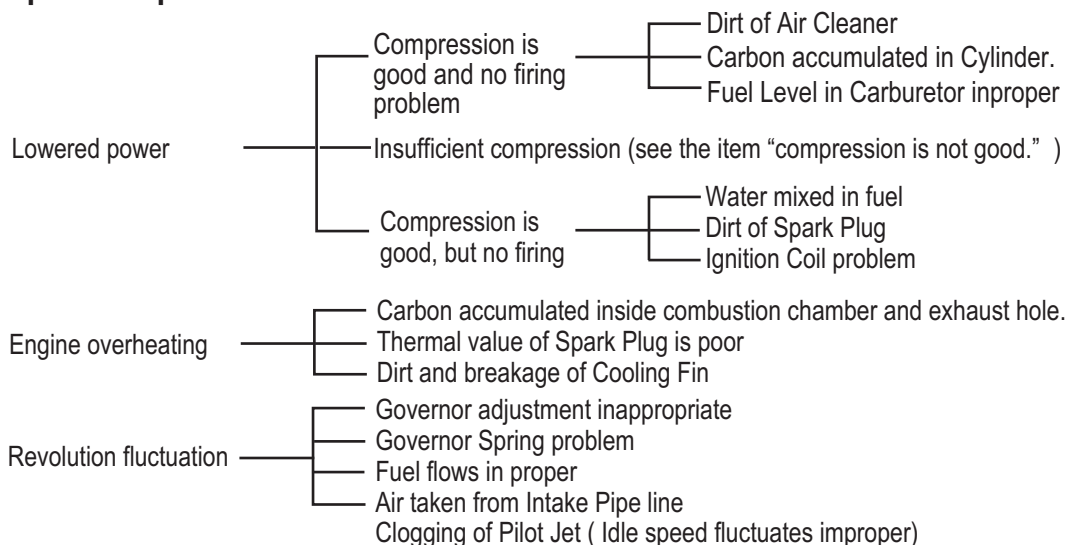

2. Main body

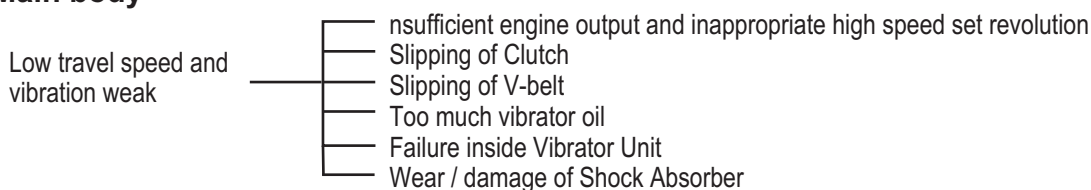



MIKASA SANGYO CO., LTD.

HEAD OFFICE
No.4-3, Sarugakucho 1-chome,
Chiyoda-ku, Tokyo, 101-0064,
Japan

<http://www.mikasas.com>