

Mikasa

PLATE COMPACTOR

MVC-F60

MVC-F70

MVC-F80

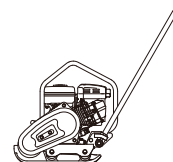

OPERATION MANUAL

en



<http://www.mikosas.com>

402-03029



EC Declaration of Conformity

1 Manufacturer's name and address	Mikasa Sangyo Co., Ltd. 1-4-3, Kanda-Sarugakucho, Chiyoda-ku, Tokyo, 101-0064, Japan								
2 Description of the equipment	Compaction machines (Vibratory Plates : Plate Compactors) <div style="text-align: center;">MVC-F60H</div> <table style="width: 100%; border: none;"> <tr> <td style="width: 50%; text-align: center;">MVC-F60H VAS</td> <td style="width: 10%; text-align: center;"> </td> <td style="width: 40%; text-align: center;">MVC-64VH</td> </tr> <tr> <td style="text-align: center;">MVC-F60H FLD</td> <td style="text-align: center;"> </td> <td style="text-align: center;">MVC-64VH W</td> </tr> </table>			MVC-F60H VAS		MVC-64VH	MVC-F60H FLD		MVC-64VH W
MVC-F60H VAS					MVC-64VH				
MVC-F60H FLD					MVC-64VH W				
2.1 Product									
2.2 Type									
2.3 Version(s)									
2.4 Measured sound power level dB(A)				101					
2.5 Guaranteed sound power level dB(A)	105								
2.6 Motor type : Net power	Air cooled , 4 stroke SI engine (Honda GX120) : 2.6 kW								
3 Conformity assessment procedure	Annex VIII of 2000/14/EC as last amended by 2005/88/EC								
4 Notified Body's name and address	TÜV Rheinland LGA Products GmbH Tillystraße 2, 90431, Nürnberg, Germany Notified Body number: NB 0197								
5 Comply with relevant provisions and requirements of the following directives and standards	2000/14/EC , 2006/42/EC , 2014/30/EU EN 500-1:2006 +A1:2009 , EN 500-4:2011								
6 Signature	 _____		2nd Jun. 2022						
	Keiichi Yoshida : Director, General Manager R&D Division								
7 Technical documentation keeper	Engineer , R&D Division , Mikasa Sangyo Co., Ltd. 15-1,Shimoosaki,Shiraoka-city,Saitama,349-0203,Japan								
Reference data	MVC-F60H	MVC-F60H VAS FOLD	MVC-64VH W						
Hand-arm vibration level ※ Ahv m/s ²	7.3	3.3 11.4	3.3						

※ Directive 2002/44/EC compliant. Test course (crushed gravel) is in comply with EN 500-4

EC Declaration of Conformity

1 Manufacturer's name and address	Mikasa Sangyo Co., Ltd. 1-4-3, Kanda-Sarugakucho, Chiyoda-ku, Tokyo, 101-0064, Japan				
2 Description of the equipment	Compaction machines (Vibratory Plates : Plate Compactors) <div style="display: flex; justify-content: space-around; align-items: center;"> <div style="text-align: center;"> MVC-F70H MVC-F80H MVC-F80H VAS MVC-F80H FLD </div> <div style="text-align: center; border-left: 1px dashed black; padding-left: 10px;"> MVC-F80H MVC-F80H VAS MVC-F80H FLD </div> <div style="text-align: center;"> MVC-82VH MVC-82VH W </div> </div>				
2.1 Product					
2.2 Type					
2.3 Version(s)					
2.4 Measured sound power level dB(A)					102
2.5 Guaranteed sound power level dB(A)					105
2.6 Motor type : Net power					Air cooled , 4 stroke SI engine (Honda GX160) : 3.6 kW
3 Conformity assessment procedure	Annex VIII of 2000/14/EC as last amended by 2005/88/EC				
4 Notified Body's name and address	TÜV Rheinland LGA Products GmbH Tillystraße 2, 90431, Nürnberg, Germany Notified Body number: NB 0197				
5 Comply with relevant provisions and requirements of the following directives and standards	2000/14/EC , 2006/42/EC , 2014/30/EU EN 500-1:2006 +A1:2009 , EN 500-4:2011				
6 Signature	 <hr style="width: 200px; margin: 0 auto;"/>			2nd Jun. 2022	
	Keiichi Yoshida : Director, General Manager R&D Division				
7 Technical documentation keeper	Engineer , R&D Division , Mikasa Sangyo Co., Ltd. 15-1,Shimoosaki,Shiraoka-city,Saitama,349-0203,Japan				
Reference data	MVC-F70H	MVC-F80H	MVC-F80H VAS FOLD	MVC-82VH W	
Hand-arm vibration level ※ Ahv m/s ²	5.8	6.7	3.8 8.4	3.5	

※ Directive 2002/44/EC compliant. Test course (crushed gravel) is in comply with EN 500-4

Table of contents

1. INTRODUCTION	1
2. MACHINE OVERVIEW	1
3. WARNING SIGNS	2
4. CAUTIONS FOR SAFETY	2
4.1 General Cautions	2
4.2 Refueling Precautions	3
4.3 Location And Ventilation Precautions	3
4.4 Precautions Before Starting	3
4.5 Precautions During Work	3
4.6 Lifting Precautions	3
4.7 Transportation And Storage Precautions	3
4.8 Maintenance Precautions	4
4.9 Decals Position	5
4.10 Descriptions Of The Warning Decals	6
5. SPECIFICATIONS	7
5.1 Body	7
5.2 Engine	7
6. APPEARANCE	8
6.1 Dimensions	8
6.2 Components	8
7. INSPECTION BEFORE OPERATION	9
8. OPERATION	12
8.1 Starting	12
8.2 Operation	13
9. STOPPING THE MACHINE	13
10. TRANSPORTATION	14
10.1 Loading And Unloading	14
10.2 Transportation	14
11. STORAGE	14
12. INSPECTION AND MAINTENANCE	15
12.1 Inspection and Maintenance Schedule	15
12.2 Change Engine Oil	15
12.3 Clean Air Cleaner	15
12.4 Check and Change V-belt & Clutch	16
12.5 Check and Change Vibrator Oil	16
12.6 Check and Change Engine Bolt	16
13. TROUBLESHOOTING	17

1. INTRODUCTION

- This operation manual describes the proper operation, basic inspection and maintenance procedures of the plate compactor. Please read this operation manual before use in order to maximize the excellent performance of this machine and make your work more efficient and effective.
- After reading the manual, please keep it in a handy location for easy reference.
- For the handling the engine, please refer to the separate engine operation manual.
- For inquiries about repair parts, parts lists, service manuals, and repairs, please contact the store where you purchased the product, our sales office, or the Mikasa Parts Service Center. For parts lists, please visit our homepage at: <http://www.mikasas.com/> where you can access Mikasa WEB parts lists.

The illustrations in this manual might slightly differ in part from the machine you actually purchased due to design changes.

2. MACHINE OVERVIEW

Application

Plate compactor is the machine that compacts the ground and it intends to make the surface smooth, by transmitting vibration through vibrating plate, which power generated from single rotor in vibrator case.

This machine is suitable for making the ground surface smooth, such as leveling the soil and sand, finishing the asphalt paving.

Warning About Incorrect Applications And Techniques

This machine is hard to move forward on a soil with much water (especially clay soil). It is not suitable for such application. This machine is difficult to level a ground include big stones due to insufficient compacting force. Plate compactor is mainly applied for compacting surface smooth and it is not effective for jobs that requires heavy compaction. In case of compacting ground deeply into lower layer, it is recommended to use Tamping Rammer, Reversible Compactor or Vibration Roller of which compacting force is rather effective. Please use this compactor for compacting surface on soil, sediment, sand and asphalt. It is not recommended for use this machine for the other applications.

Structure





The upper part is made up of Power source, Handle, Belt Cover, Water Tank for sprinkling and Guard Hook which are fixed by Engine Base. The Engine base is fixed on Vibrating Plate by Shock Absorbing Rubber. The lower part is made up of Vibrating Plate and Vibrator Unit that has an Eccentric rotary shaft built in. The power source is transmitted from the centrifugal clutch on engine output shaft to the Eccentric rotary shaft through V-belt.

Power Transmission

Air-cooled Single Cylinder Engine is amounted as power source and Centrifugal Clutch is fixed on engine output shaft. Centrifugal Clutch engages by running up the engine and engine R.P.M. is reduced to suitable number for compacting. The rotation of engine is transmitted from V-pulley integrated with Clutch Drum to Vibrator Pulley through V-belt. Vibrator Pulley rotates Eccentric Rotor Shaft that is contained in Vibrator Case. The generated vibration created from Eccentric Rotor is transmitted to Vibrating Plate. Vibration of Vibrating Plate carries the machine forward; the vibration with the weight of the machine makes the compaction of the ground possible.

3. WARNING SIGNS

The triangle shaped  marks used in this manual and on the decals stuck on the main body indicate common hazards. Be sure to read and observe the cautions described.

 Warning labels indicating hazards to humans and to equipment.	
 DANGER	Denotes an extreme hazard. It calls attention to a procedure, practice, condition or the like, which, if not correctly performed or adhered to, is likely to result in serious injury or death.
 WARNING	Denotes a hazard. It calls attention to a procedure, practice, condition or the like, which, if not correctly performed or adhered to, could result in serious injury or death.
 CAUTION	Denotes a hazard. It calls attention to a procedure, practice, condition or the like, which, if not correctly performed or adhered to, could result in injury to people and may damage or destroy the product.
CAUTION (without at )	Failure to follow the instructions may result in damage to property.

4. CAUTIONS FOR SAFETY

4.1 General Cautions

WARNING

- Do not work with this machine, when
 - you are tired or sick and not feeling well.
 - you have taken medicine or drug.
 - you have had a drink.



CAUTION

- Please read the operation manual well and work safely by using the machine properly.
- For handling of the engine, please refer to the separate engine operation manual.
- Please have a good understanding of the structure of this machine.
- Make sure to do work start inspection, regular self inspection and specified self inspection.
- To make your work safe, please use protective equipment (use specified helmet, protective shoes, etc.) and wear appropriate work clothes.
- Always use noise protection equipment such as ear muffs or ear plugs.
- Always check the machine to make sure it is in normal condition before operating the machine.
- The nameplates attached to the machine (nameplates showing operation method, warning, etc.) are very important for your safety. Clean the machine so that the nameplates can be read easily. If it is difficult to read the nameplate, please replace the old one with a new one.
- It is dangerous for young children to come near the machine. Please pay careful attention to the method of storing and the storage location for this machine. Especially the engine start key has to be taken out every time you finish your work, and keep it in a designated location.
- To do maintenance work, stop the engine and remove the battery wiring.
- We are not responsible for accidents that have occurred after the machine was refurbished without approval from the manufacturer.



4.2 Refueling Precautions

DANGER

- Always refuel in a well ventilated area.
- Make sure to stop the engine and wait until the engine cools down when refueling.
- Select a flat surface area with no flammable material around for refueling. Be careful not to spill the fuel. Wipe off well if there is any spill.
- Never put fire near the machine during refueling. (Especially, be careful about smoking.)
- If you fill to the top of the fuel tank inlet, fuel might spill out from the tank, and it becomes dangerous
- After refueling, tighten the tank cap well.



4.3 Location And Ventilation Precautions

DANGER

- Do not run the machine in an unventilated location, such as indoors or inside a tunnel. The exhaust gas from the engine contains toxic gases such as carbon monoxide and is very hazardous.
- Do not operate the machine near open flames.



4.4 Precautions Before Starting

CAUTION

- Check each part to see if it is tightened properly. Vibration causes loosening of bolts, which results in unexpected serious malfunctions of the machine. Tighten the bolts securely.

4.5 Precautions During Work

CAUTION

- Before starting the machine, make sure it is safe to start by checking your surroundings for people and objects.
- Always pay attention to your footing. Work in an area where you can maintain a good balance of the machine and a safe comfortable posture.
- The engine and muffler become very hot. Do not touch immediately after the machine stops because they are still very hot.
- If you notice deterioration of machine operation during your work, stop your work immediately.
- When moving away from the machine, stop the engine and make sure that the machine is completely tied down. Stop the engine also when moving the machine to other location.
- Keep fingers, hands, hair and clothing away from all moving parts (such as inside the belt cover) to prevent injury.
- Work on sloping ground is very dangerous. Pay full attention for safe operation of the machine during working on sloping ground.
- Keep both hands on the handle during working on sloping ground to prevent accident.
- Never leave the machine unattended on sloping ground. Serious accident might occur if the machine left unattended begins to move.
- In case of the machine with electric starter, do not operate without the battery. If you operate without the battery, electrical system failure might occur.



4.6 Lifting Precautions

DANGER

- Before lifting, check the machine parts (especially the hook and shock absorbers) for any damage and loosened or missing bolts.
- Stop the engine and close the fuel cock during lifting.
- Use a sufficiently strong wire rope.
- For lifting, use only the lifting hook, and do not lift at any other part.
- When the machine is lifted, never let people or animals come underneath.
- For safety reasons, do not lift to a height that is higher than necessary.



4.7 Transportation And Storage Precautions

WARNING

- Stop the engine and close the fuel cock during transportation.
- Transport after the engine and the machine are cooled down.
- Always drain the fuel before transporting.
- Tie down the machine securely to prevent the machine from moving or falling during transportation.



4.8 Maintenance Precautions

WARNING

- Appropriate maintenance is required to ensure safe and efficient operation of the machine. Always pay attention to the machine's condition and keep it in good condition. Pay special attention to the parts used for lifting, if they are not maintained properly, it might result in a serious accident.
- Start maintenance work after the machine has cooled down completely. The muffler, in particular, becomes very hot, and there is a danger of burn. The engine, engine oil and vibrator also become very hot. Be careful not to get burned.



CAUTION

- Always stop the engine before inspection and adjustment. If you are caught in a rotating part, serious injury might occur.
- After maintenance work, check the security parts to see if they are securely installed. Special attention should be paid when checking bolts and nuts.
- If disassembly is involved in maintenance, refer to the maintenance instruction manual to make your work safe.



About The Battery

DANGER

- If the battery fixing bolts have been removed, put them back and tighten securely to fix the battery.
If used with the battery not fixed properly, contact with the battery terminal might occur, leading to electric shock and electric leak, or breakage of the battery might occur by the impact and vibration from outside, resulting in battery fluid leakage.
- The gas from the battery might cause an explosion. Do not generate sparks or bring flames near the battery.
- Never put the positive terminal and negative terminal come into contact. Sparks will be generated, and ignition might occur.

WARNING

- Be careful when handling the battery fluid because it is very toxic. If the battery fluid gets on your skin, eye, or clothes, rinse it off with plenty of water and consult with a doctor.

4.9 Decals Position

MVC-F60/F70/F80

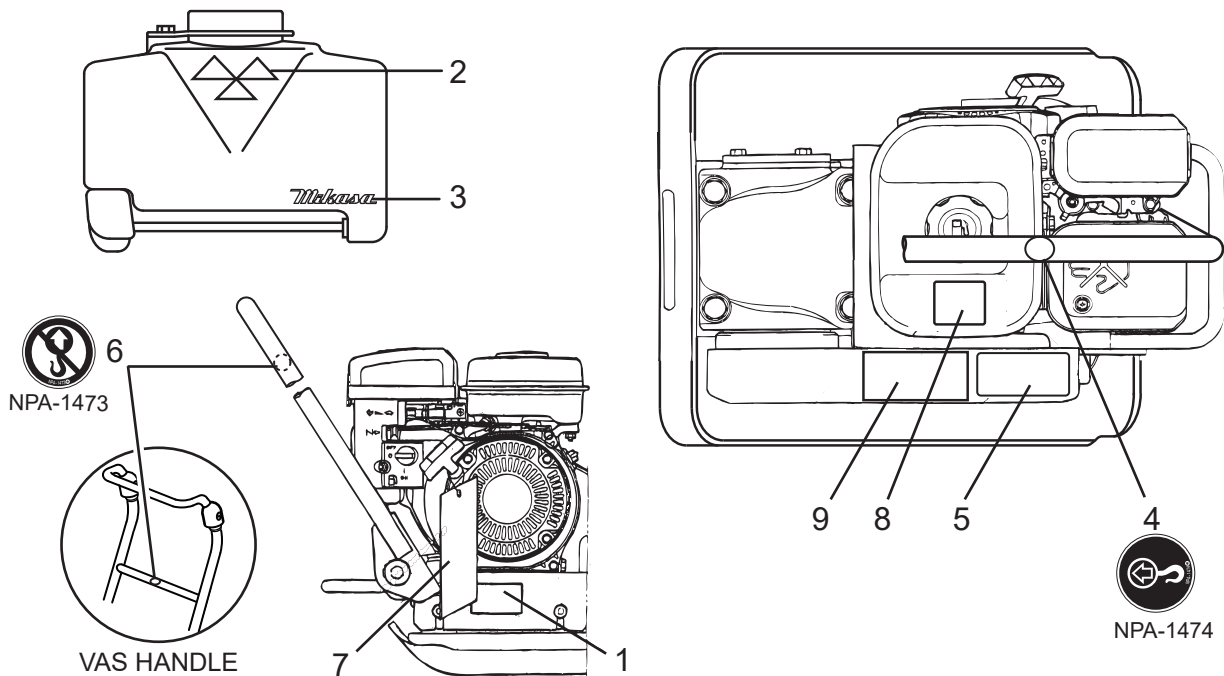

※ Specifications are subject to change without notice.

REF No.	PART No.	PART NAME	Q' TY	DECAL No.	REMARKS
1	—	PLATE, SERIAL NO. / EU	1	—	
2	9201-01410	DECAL, MIKASA MARK 120X60	1	NP-141	WATER TANK
3	9201-14000	DECAL,MIKASA MARK 125MM	1	NP-1400	WATER TANK
4	9209-00090	DEAL,LIFTING POSITION	1	NPA-1474	
5	9209-00090	DEAL,CAUTION ICONS	1	NPA-1479	Warning Decals
6	9209-00090	DECAL,DO NOT LIFTING	1	NPA-1473	
7	9202-00870	DECAL, WITHOUT ENGINE OIL	1	NPA-87	
8	9202-10330	DECAL,EC NOISE REQ.LWA105	1	NPA-1033	
9	9209-00090	DECAL,ENGINE HANDLING /GS	1	NPA-1480	Starting and Stopping

4.10 Descriptions Of The Warning Decals

P/N 9209-00090 DECAL, SET /MVC, MCD /EXP,EU includes NPA-1473, 1474, 1479 and 1480.

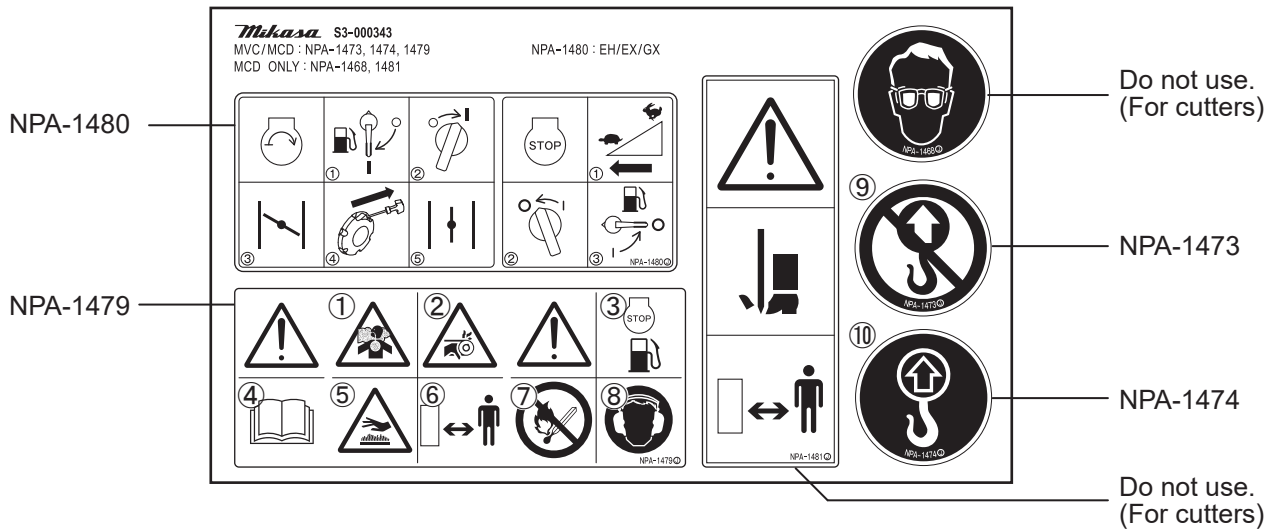

- ① **Lethal Exhaust Gas Hazard.**
Carbon monoxide poisoning may occur if the exhaust gas is inhaled. Do not operate the machine in a poorly ventilated area.
- ② **Rotating Parts Hazard.**
Keep hands clear from all moving parts (such as inside the belt cover) to prevent injury.
- ③ **Refueling Hazard.**
Stop the engine and let cool before refueling.
- ④ **Read the manual carefully.**
Read and fully understand the operation manual before operating the machine.
- ⑤ **Burn Hazard.**
Never touch the hot parts. Allow these parts to cool before servicing the machine.

- ⑥ **Keep safe distance.**
Be careful not to approach danger source during operation.
- ⑦ **Fire hazard.**
Keep away any flames and sparks from the machine.
- ⑧ **Noise hazard.**
Always wear ear protection while operating the machine.
- ⑨ **No lifting position.**
Do not use any other points (such as the handle) except one point lifting hook for lifting the machine.
- ⑩ **Lifting position.**
Use one point lifting hook for lifting the machine.

Starting and stopping for gasoline engine

START

- ① Open Fuel Cock to start.
- ② Turn Stop Switch to "I"(ON) position.
- ③ Close Choke Lever.
- ④ Pull Recoil Starter to start the engine.
- ⑤ Return Choke Lever to open.

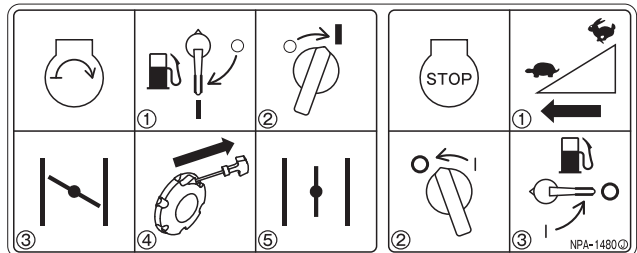

STOP

- ① Return Throttle Lever fully until "O"(OFF) position to stop work.
- ② After cooling down enough, turn Stop Switch to "O"(OFF) position to stop the engine.
- ③ Close Fuel Cock at the end.

5. SPECIFICATIONS

5.1 Body

Model		MVC-F60H (VAS)	MVC-F70H	MVC-F80H (VAS)
Engine		Honda GX120	Honda GX160	Honda GX160
Operating Weight				
With Water Tank	kg	73 (88)	81	87 (101)
Without Water Tank		65 (80)	73	78 (92)
Overall Length		925 (915)	925	925 (915)
Overall Width	mm	350	420	450
Overall Height		865 (995)	865	865 (995)
Plate Size (W x L)	mm	350 x 510 (570)	420 x 510	450 x 570
Travelling Speed	m/min	25	25	25
Vibrating Frequency	Hz (vpm)	93 (5600)	93 (5600)	93 (5600)
Centrifugal Force	kN (kgf)	10.1 (1030)	12.0 (1220)	13.7 (1400)
Vibrator Oil Grade		SAE 10W-30	SAE 10W-30	SAE 10W-30
Vibrator Oil Capacity	liters	140	140	140
Water Tank Capacity	liters	11	11	13
V-Belt Size		RPF3310	RPF3310	RPF3310

Remarks: 1) VAS = Vibration Absorbing System

2) Machine weight when it is equipped with a revolving type moving cart will increase to 2kg each weight.

5.2 Engine

Manufacturer		Honda	Honda
Model		GX120	GX160
Max. Output		2.6kW (3.5PS) / 4000rpm	3.6kW (4.9PS) / 4000rpm
Fuel Tank Capacity	liters	2.0	3.1
Engine Oil Grade		API SE or later SAE 10W-30	API SE or later SAE 10W-30
Engine Oil Capacity	liters	0.56	0.58
Starter		Recoil	Recoil
Operating Engine Speed	rpm	3600	3600

(The specifications may be changed without notice.)

6. APPEARANCE

6.1 Dimensions

MVC-F60(VAS)
MVC-F70
MVC-F80(VAS)

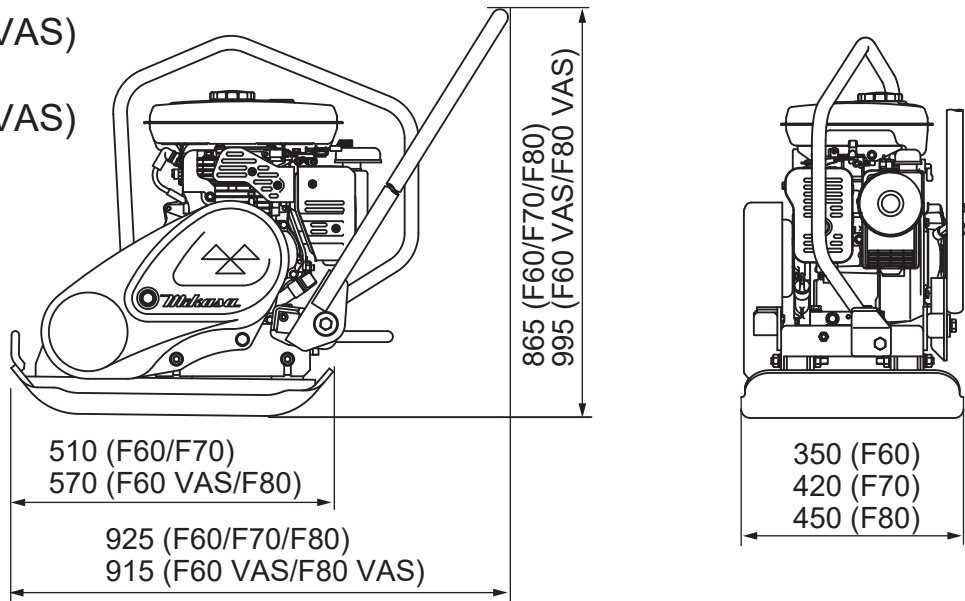

※ The illustration is shown for model "MVC-F60".
※ Specifications are subject to change without notice.

6.2 Components

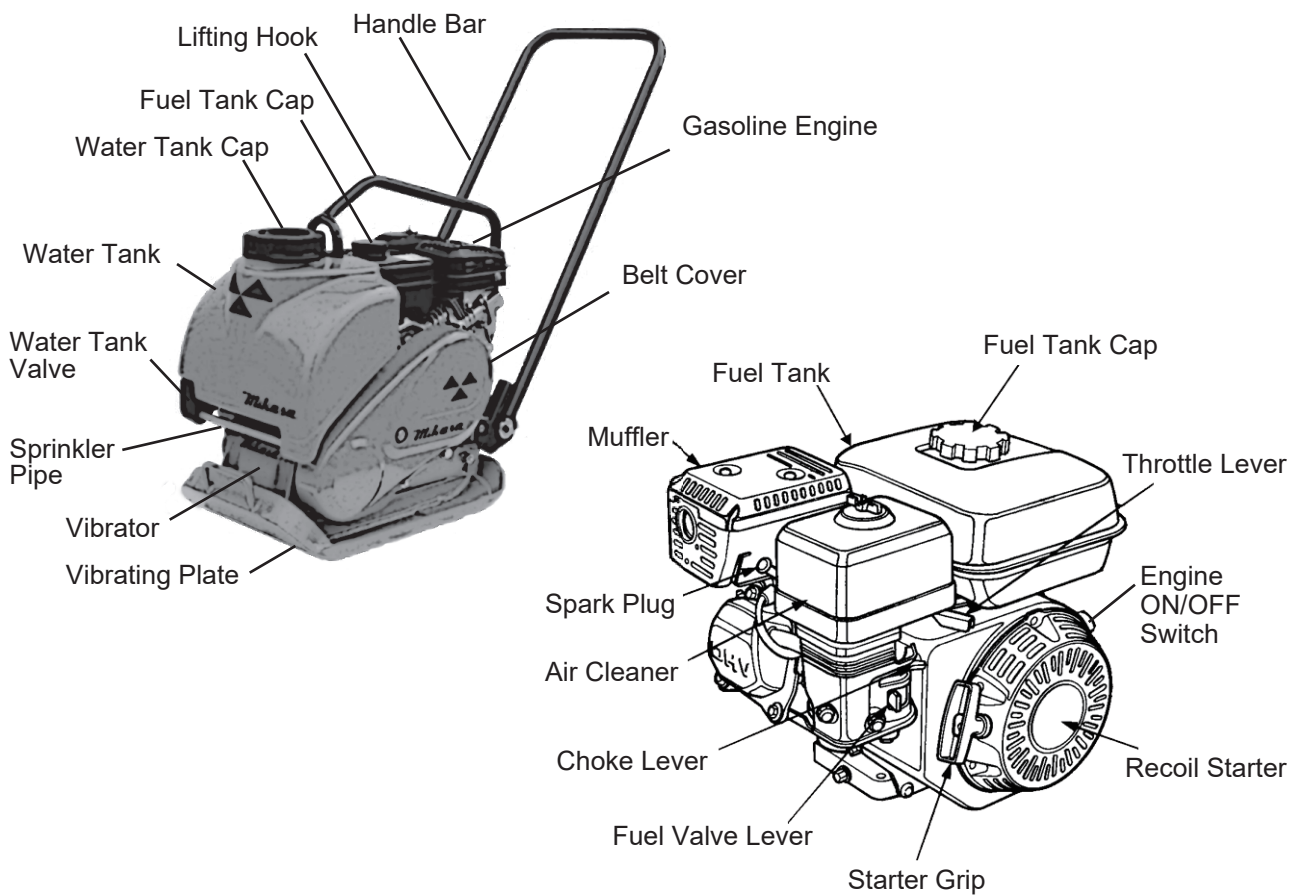

※ The illustration is shown for model "MVC-F60".

7. INSPECTION BEFORE OPERATION

⚠ DANGER

- Always stop the engine before inspection. You may be caught in a rotating part and be seriously injured.
- Check the machine after it has cooled down to avoid burns.
- Check the machine after it puts on hard and level ground.

● Refer to the "Regular Check and Adjustment" on page 17 for the inspection points before starting operation.

1. Clean the machine. Remove dirt and dust of the engine cooling air inlet, carburetor and air cleaner particularly.
2. Check each part for any looseness of bolts and nuts. Vibration causes bolts and nuts to loosen, which might result in unexpected accident or malfunction.
3. Inspect the guard hook, belt cover and shock absorber, as well as to check the function of speed adjustment wire and speed adjusting lever.
4. Check the V-belt tension. The V-belt tension is proper if the V-belt bents 10 to 15 mm when depressed with finger at midway between the clutch and vibrator pulleys.
5. Check the engine oil level. If the oil level is low, refill the oil. (Fig. 1)
Use the following engine oil.

Oil grade: API SE or later SAE10W-30
Refer to the following table for viscosities depending on ambient temperature.

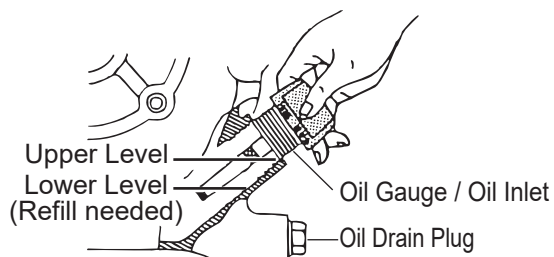
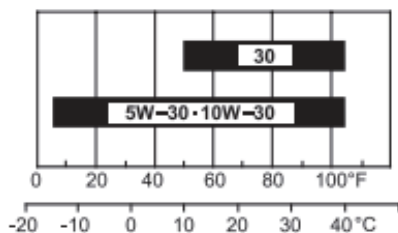
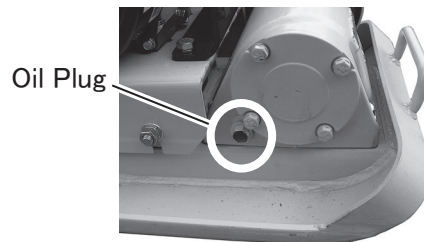

Fig. 1

6. Remove the oil plug of the vibrator. Check that vibrator oil is provided up until the lower of the hole of the oil plug. Use the engine oil #10W-30 for vibrator oil. Vibrator oil quantity is 140 cc.



MVC-F60/F70/F80

Fig. 2

7. A regular grade gasoline or diesel oil should be used in the engine. When filling the fuel tank, make sure the fuel filter is used.

⚠ DANGER

- Never refueling near a naked flames or a source of sparks.
- Do not fill the fuel tank completely because the fuel might spill.
- Wipe up any spilled fuel.

8. Pour water into the water tank for sprinkling work. (Fig.3)

⚠ CAUTION

- Pour water only. If you should put liquids other than water, the resin, tank cap seal, etc. may deteriorate or swell, leading to leakage or damage.

The water tank can be removed by pulling it upward. When mounting the water tank again, insert the hook into the groove of the water tank securely.

The amount of sprinkling water can be adjusted by the valve of water tank.

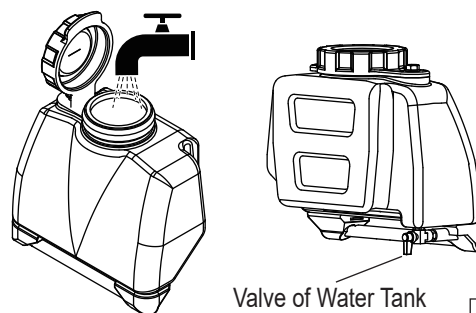
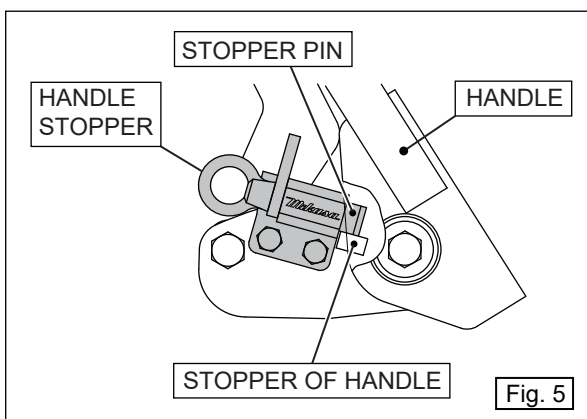
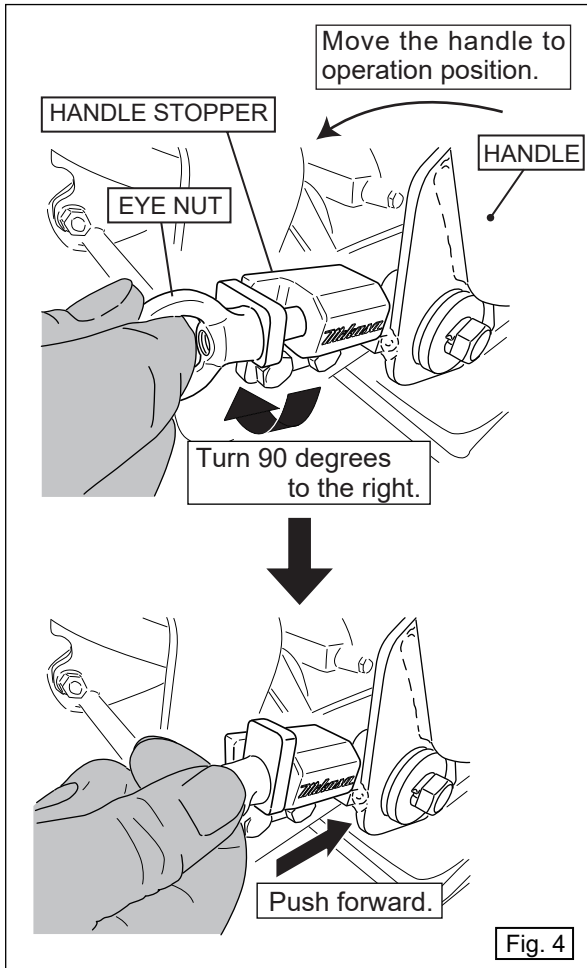

Fig. 3

HOW TO USE THE REVOLVING CART.

● From storage position to carrying position.

1. Move the handle to operation position (backward), and then lock the handle with the handle stopper certainly. (Fig.4, Fig.5)



2. Unlock the lock for revolving cart, and then move the revolving cart until contacting the ground. (Fig.6)

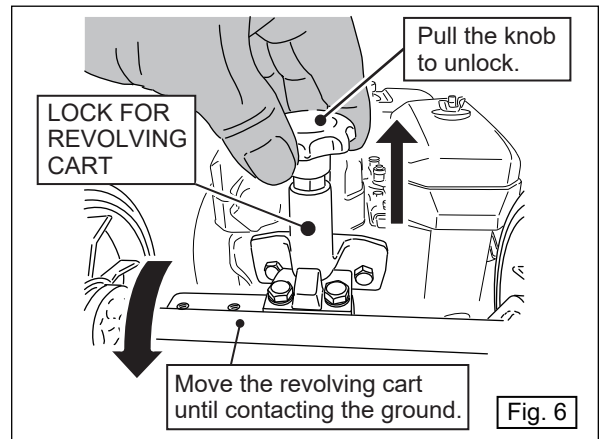

3. Tilt the handle forward until leaving the vibrating plate from the ground, and then revolve the revolving cart into the under vibrating plate with foot. (Fig. 7)

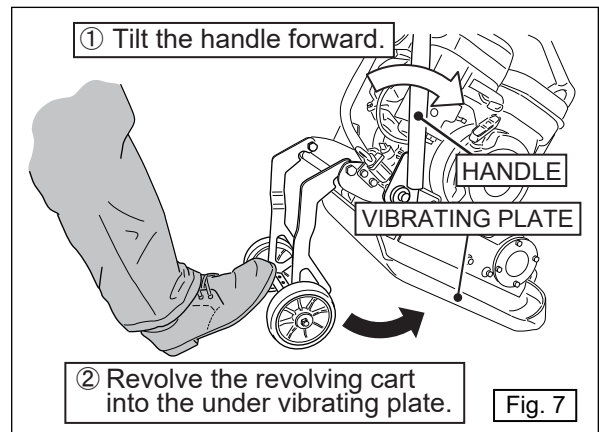

4. Pull back the handle until the vibrating plate leaves the ground, and then push and pull the handle the machine forward and backward. (Fig.8)

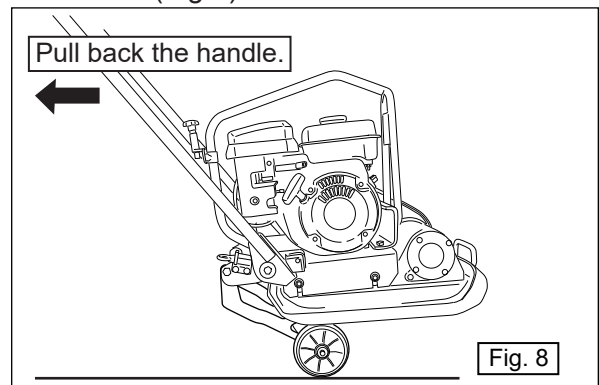

● From carrying position to storage position.

Return the revolving cart to the storage position with reversed procedure of "From storage position to carrying position". Check that fix the revolving cart at storage position certainly.

8. OPERATION

⚠ DANGER

- The engine exhaust gas contains carbon dioxide and is very dangerous.
- Do not use this machine where ventilation is poor.

8.1 Starting

1. Turn the lever of the fuel cock downward and feed fuel. (Figs. 13)

Fuel cock (HONDA)

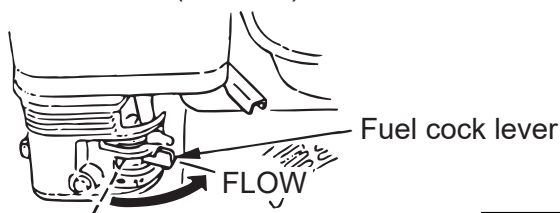

Fig. 13

2. Turn the stop switch to "ON (I)" position. (Fig. 14)

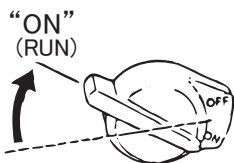

Fig. 14

3. Open the speed control lever half. (Fig. 15)

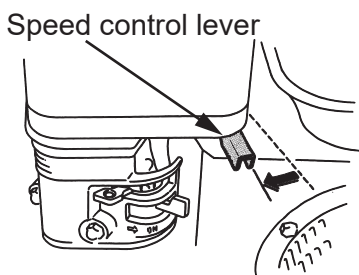

Fig. 15

4. When it is cold or the engine does not start easily, close the choke lever. (Figs. 16)

Choke (HONDA)

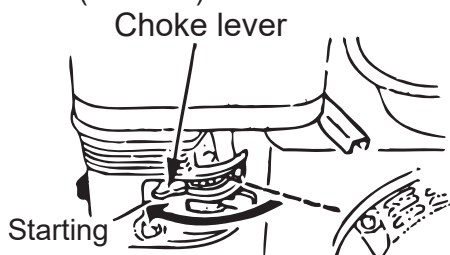

Fig. 16

5. Grip the starting knob of the recoil starter. When you pull the rope a little, you will feel some resistance. Then pull it at a stroke. Be careful not to pull the rope too strongly, or the rope may break or come off. (Fig. 17)

Starter Grip (HONDA)

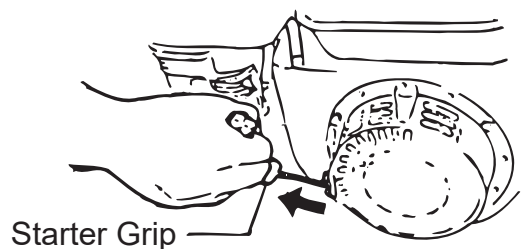

Fig. 17

6. When the engine has started, return the speed control lever to the low speed position immediately. Listening to the sound of the explosion, return the choke lever gradually to the fully open condition. (Fig. 18)

Choke (HONDA)

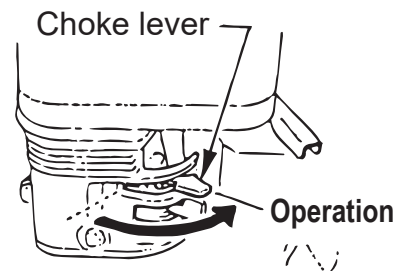

Fig. 18

7. After the start, be sure to conduct the warm-up operation at low speed for 2-5 minutes. This is particularly important when it is cold. During this time, check for any abnormalities such as gas leakage.

Note:

If you leave the speed control lever half-open, the centrifugal clutch turns into a slipped state. This may cause a failure of the centrifugal clutch, and also cause abnormal vibration of this machine, which is very dangerous. So, as soon as the engine has started, return the speed control lever to the low-speed position.

8.2 Operation

1. If you open the speed control lever at a stroke, this machine starts vibration and moves forward. If you open it slowly, the clutch may slip, so open the speed control lever at a stroke without hesitation. (Refer to Fig.15 on page 13.)
2. When this machine is used on cohesive soils, the vibrating plate does not move over the ground easily and the travel speed becomes slow. Check that clay is not adhering to the bottom of the compaction board. The compaction force of this machine does not act effectively on cohesive soils or soils of a high moisture ratio. In this case, use other machine such as a rammer, or dry the soils and decrease the moisture ratio.
3. When conducting sprinkling work, open the cock of the water tank.
4. When you stop the operation, return the speed control lever at a stroke.

9. STOPPING THE MACHINE

1. When you finish the work and stop the engine, return the speed control lever to the low speed position, and keep the engine running at low speed for 3-5minutes. When the temperature of the engine has decreased, stop the engine.

CAUTION

If you stop the engine while it is still hot, this machine will be affected adversely, causing, for example, burning of the oil film on the inner wall of the cylinder, which may accelerate wear of the inner wall of the cylinder. This may result in a shorter life of this machine, or cause unexpected failure.

2. Turn the engine switch to the OFF position, then the engine stops. (Fig. 19)

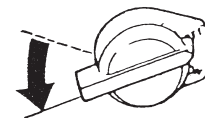

“OFF”
(Stop)

Fig. 19

3. Close the lever of the fuel cock. (Fig. 20)

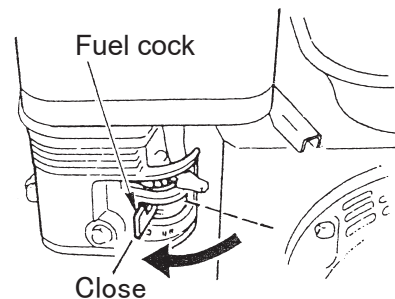

Fig. 20

4. When you have conducted sprinkling work, close the cock of the water tank.

10. TRANSPORTATION

10.1 Loading And Unloading

WARNING

- Make sure there is no breakage of guard frame and anti-vibration rubber nor loosened or missing bolts.
- Always stop the engine when lifting.
- Use an intact wire rope without any deformation with sufficient strength.
- Slowly lift upward without applying any impact. Never let people or animals go under the lifted machine.
- For safety reasons, do not lift to a height that is higher than necessary.

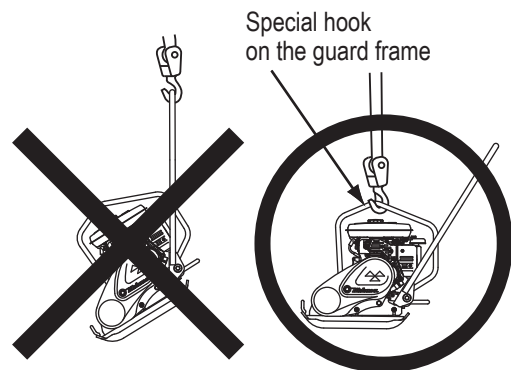

Fig. 21

1. Use a crane for loading and unloading the machine.
2. Designate a person to guide the loading and unloading, and always work under the instruction of that person.
3. When lifting, always use a hook. (Fig. 21) Never lift by using the hook on the handle.

10.2 Transportation

WARNING

- Stop the engine when the machine is transported.
- Always drain the fuel before transportation.
- Tie down the machine securely to prevent the machine from moving or falling.

11. STORAGE

1. Wash with water to remove any dust and dirt from all parts of the machine.
2. Store in a dry area away from direct sunlight after putting the cover over the machine to prevent dust and dirt buildup. (When storing this machine for an extended period of time)
3. Drain the fuel from the fuel tank, fuel pipe, and carburetor completely.
4. Conduct fueling and replenishment/change of oil without omission. Remove the spark plug, put a few drops of engine oil into the cylinder, and rotate the engine manually for spreading the oil inside sufficiently.
5. Securely cover the air cleaner and muffler air inlets and exhaust port.
6. Do not leave the machine outdoors. Keep it indoors.
7. Do not store this machine by laying it on its side (or backward).

12. INSPECTION AND MAINTENANCE

12.1 Inspection and Maintenance Schedule

Inspection interval	Inspection parts	Inspection items	Remarks
Daily (before starting operation)	Appearance	Deformation, Breakage, Crack, Dirt	
	Fuel tank	Leakage	
	Fuel system	Leakage	
	Engine oil	Leakage, oil level, dirt	Engine oil
	Shock absorber	Deformation, Breakage, Crack	
	Vibrator oil	Leakage	Engine oil
	Air cleaner element	Dust, Dirt	
	Guard frame	Deformation, Breakage, Crack	
	Bolts and nuts	Looseness, missing	
After first 20 hours	Engine oil	Change once after the first 20 hours.	Engine oil
Every 100 hours	Engine oil	Change	Engine oil
	Vibrator oil	Leakage, Oil level, Dirt	Engine oil
Every 200 hours	V-belt for vibrator	Tension, Wear, Deformation, Crack	
	Clutch	Wear, Burnout, Dust, Dirt	
	Engine bolt	Wear, Deformation, Degradation	
Every 300 hours	Vibrator oil	Change	Engine oil
	Fuel filter	Change	
Every 2 years	Fuel pipes	Change	
As needed.	Air cleaner element	Change	

For details about the check and maintenance of the engine, please refer to the attached engine operation manual.

Caution: The above table shows the check frequency for standard condition.

The check frequency may vary depending on the condition in which the machine is used.

For check of bolt and nut looseness and tightening, please see the following tightening torque list.

Tightening torque list (unit: kgf-cm, 1kgf-cm=9.80665N-cm)

		Thread diameter							
		6mm	8mm	10mm	12mm	14mm	16mm	18mm	20mm
Material	4T(SS400)	70	150	300	500	750	1,100	1,400	2,000
	6-8T(S45C)	100	250	500	800	1,300	2,000	2,700	3,800
	11T(SCM435)	150	400	800	1,200	2,000	2,900	4,200	5,600
	When the mating material is aluminum.	100	300~350	650~700	(Bolts used on the machine are all right-hand thread.)				

12.2 Change Engine Oil

Perform the first engine oil change after 20 hours of operation, then change at every 100 hours.

12.3 Clean Air Cleaner

When the air cleaner element becomes dirty, the engine does not start smoothly, and sufficient output cannot be obtained. Machine operation will be affected and the engine life will be shortened greatly. Do not forget to clean the element. (For details, please see the separate engine operation manual.) If the element cannot be cleaned, replace it with a new one.

12.4 Check and Change V-belt & Clutch

CAUTION

- When the vibration weakens during operation, or this machine does not vibrate at all though the engine rotates normally, conduct the inspection or change of the V-belt and clutch without regard to the regular inspection of every 200 hours.
- Always stop the engine before inspection and adjustment. If you are caught in a rotating part, serious injury might occur.

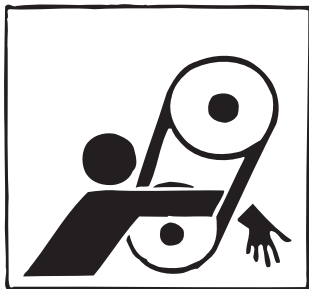

1. Check V-belt

Remove the belt cover and check the V-belt tension every 200 hours. The V-belt tension is proper if the V-belt bends 10 to 15 mm when depressed with finger at midway between the clutch and vibrator pulley.

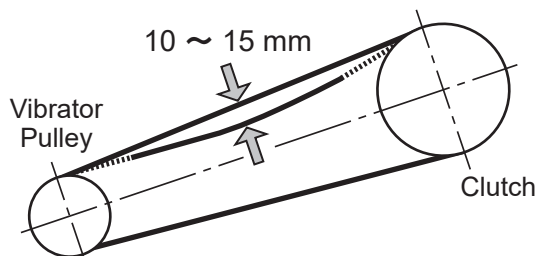

2. Check the Clutch

Inspect Clutch concurrently with the inspection of V-belt. Check visually for burning of each clutch-shoe. Check for wear the lining shoe or the like, in the operation check. If the shoe wears, power transmission is not performed properly and Clutch slips. Check wear or any damage to V-groove also. If V-groove is stained, clean it thoroughly.

3. Check the Engine Bolt

A part of Engine bolt is made of rubber, and wear and deterioration of the rubber will be reduced the tension of the V-belt. Whenever checking V-belt, inspect this part for the reason as well as Shock Absorbing Rubber. (Fig.22)

12.5 Check and Change Vibrator Oil

1. Make this machine level, and remove the oil plug of the vibrator.
2. Check that vibrator oil is provided up until the lower of the hole of the oil plug.
3. The oil plug is on the right side of the vibrator case (opposite to the belt side). (Refer to Fig.1 on page 9.)
4. Use the engine oil #10W-30 for vibrator oil. Vibrator oil quantity is 140 cc.
5. Drain the vibrator oil completely by removing the plug and tilting the body once a month or every 200 hours' operation. Replace with new oil.

12.6 Check and Change Engine Bolt

Check the condition of engine bolt.

If the engine bolt is damaged, worn and deformed, V-belt tension becomes low and DC power unit is damaged due to contact between the engine bolt and vibrating plate directly.

Replace with new one when the thickness of rubber of engine bolt mount becomes 10mm or less. (Fig.22)

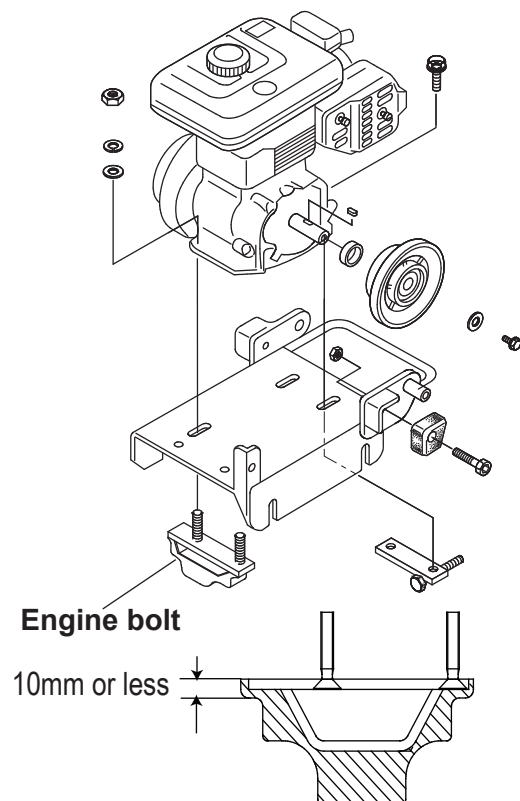

< Shaded section of Engine bolt is made of rubber. >

Fig. 22

13. TROUBLESHOOTING

(1) Starting problems

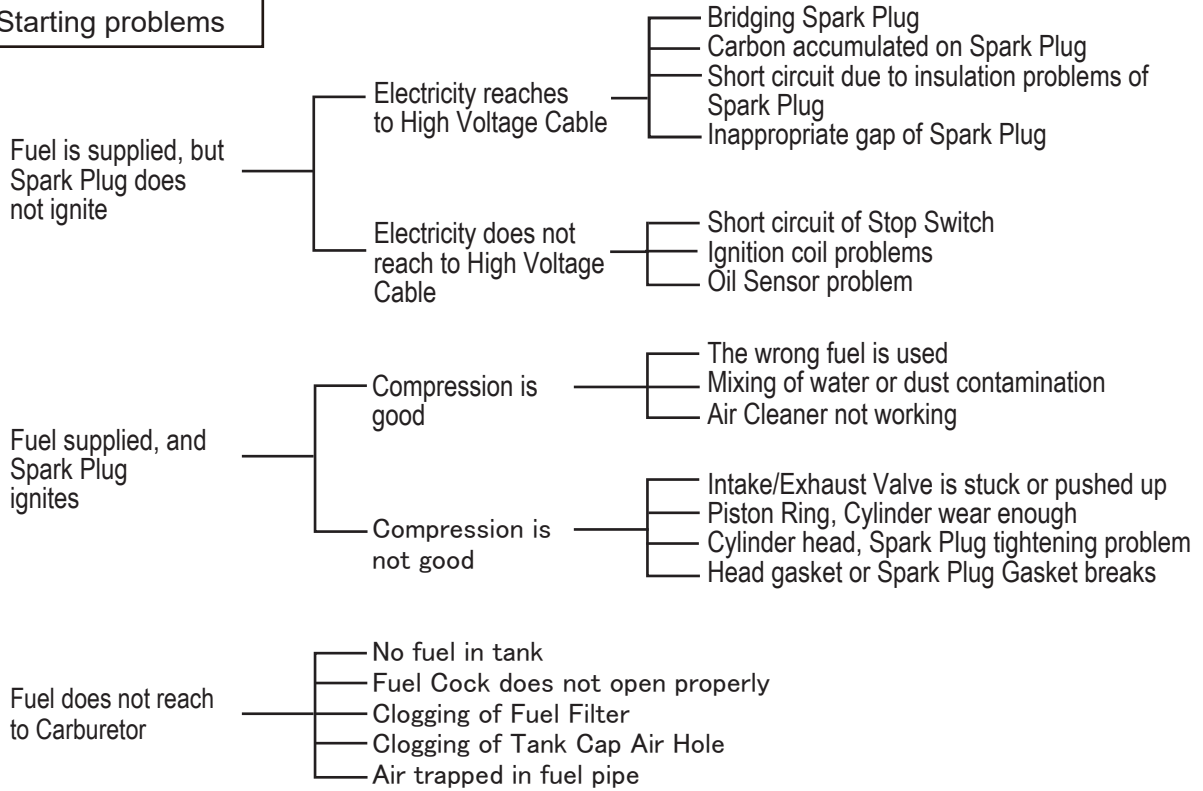

(2) Operation problems

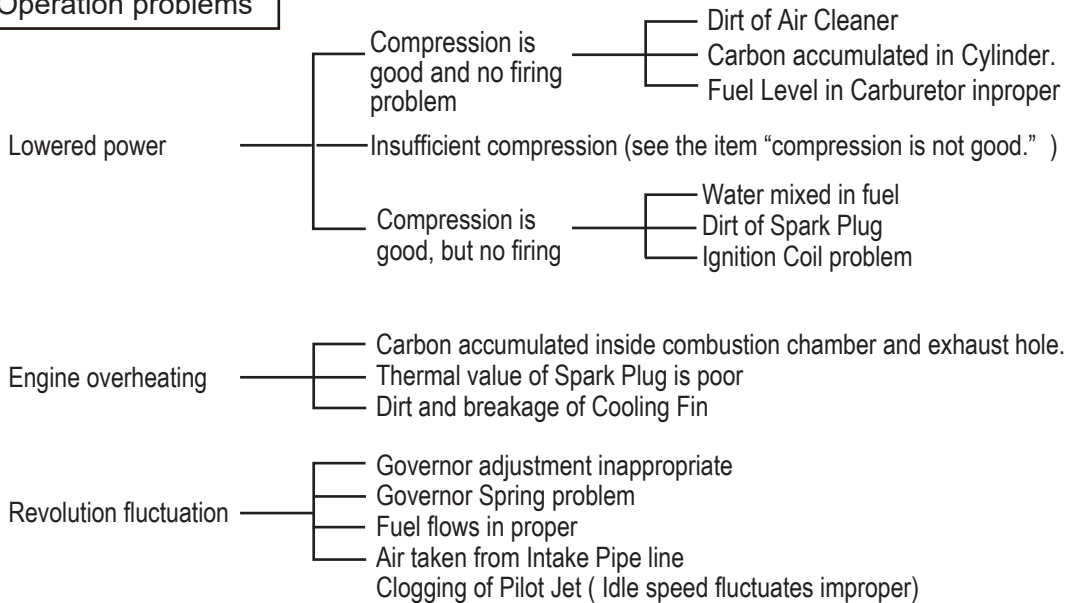

(3) Recoil starter problems

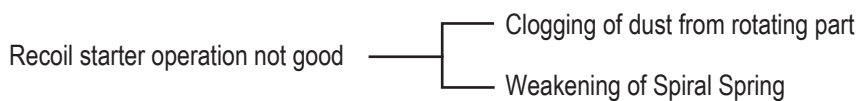

Mikasa

MIKASA SANGYO CO., LTD.

1-4-3, Kanda-Sarugakucho, Chiyoda-ku, Tokyo, 101-0064, Japan

PRINTED IN JAPAN