

Mikasa

TAMPING RAMMER

MTX-50E

MTX-60E/FE/HDR

MTX-70E/FE/HDR

MTX-80HDR

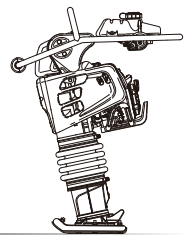

OPERATION MANUAL

en



<http://www.mikosas.com>

302-02820



EC Declaration of Conformity

1 Manufacturer's name and address	Mikasa Sangyo Co., Ltd. 1-4-3, Kanda-Sarugakucho, Chiyoda-ku, Tokyo, 101-0064, Japan																				
2 Description of the equipment	Compaction machines (Tamping Rammers) <div style="text-align: center;"> <table style="width: 100%; border-collapse: collapse;"> <tr> <td colspan="6" style="text-align: center;">MTX-70HD</td> </tr> <tr> <td style="width: 33%; text-align: center;">MTX-50HD</td> <td style="width: 33%; text-align: center;">MTX-60HD</td> <td style="width: 33%; text-align: center;">MTX-70E</td> </tr> <tr> <td style="text-align: center;">MTX-50E</td> <td style="text-align: center;">MTX-60E</td> <td style="text-align: center;">MTX-70FE</td> </tr> <tr> <td></td> <td style="text-align: center;">MTX-60FE</td> <td></td> </tr> </table> </div>						MTX-70HD						MTX-50HD	MTX-60HD	MTX-70E	MTX-50E	MTX-60E	MTX-70FE		MTX-60FE	
MTX-70HD																					
MTX-50HD							MTX-60HD	MTX-70E													
MTX-50E							MTX-60E	MTX-70FE													
							MTX-60FE														
2.1 Product																					
2.2 Type																					
2.3 Version(s)																					
2.4 Measured sound power level dB(A)	104																				
2.5 Guaranteed sound power level dB(A)	107																				
2.6 Motor type : Net power	Air cooled , 4 stroke SI engine (Honda GX100) : 2.1 kW																				
3 Conformity assessment procedure	Annex VIII of 2000/14/EC as last amended by 2005/88/EC																				
4 Notified Body's name and address	TÜV Rheinland LGA Products GmbH Tillystraße 2, 90431, Nürnberg, Germany Notified Body number: NB 0197																				
5 Comply with relevant provisions and requirements of the following directives and standards	2000/14/EC , 2006/42/EC , 2014/30/EU EN 500-1:2006 +A1:2009 , EN 500-4:2011																				
6 Signature	 <hr style="width: 200px; margin: 0 auto;"/>					Mar. 2024															
	Kenichi Nagasawa : Director, General Manager R&D Division																				
7 Technical documentation keeper	Engineer , R&D Division , Mikasa Sangyo Co., Ltd. 15-1,Shimoosaki,Shiraoka-city,Saitama,349-0203,Japan																				
Reference data	MTX-50		MTX-60		MTX-70																
	HD / E	E Hi HDL	HD / E / FE	E Hi HDL	HD / E / FE	E Hi HDL															
Hand-arm vibration level ※ Ahv m/s ²	4.9		5.2		5.6																

※ Directive 2002/44/EC compliant. Test course (crushed gravel) is in comply with EN 500-4

EC Declaration of Conformity

1 Manufacturer's name and address	Mikasa Sangyo Co., Ltd. 1-4-3, Kanda-Sarugakucho, Chiyoda-ku, Tokyo, 101-0064, Japan		
2 Description of the equipment	Compaction machines (Tamping Rammers)		
2.1 Product	MTX-80HDR		
2.2 Type	MTX-80HDR		
2.3 Version(s)	MTX-60HDR	MTX-70HDR	MTX-80HDR
2.4 Measured sound power level dB(A)	104		
2.5 Guaranteed sound power level dB(A)	107		
2.6 Motor type : Net power	Air cooled , 4 stroke SI engine (Honda GXR120) : 2.7 kW		
3 Conformity assessment procedure	Annex VIII of 2000/14/EC as last amended by 2005/88/EC		
4 Notified Body's name and address	TÜV Rheinland LGA Products GmbH Tillystraße 2, 90431, Nürnberg, Germany Notified Body number: NB 0197		
5 Comply with relevant provisions and requirements of the following directives and standards	2000/14/EC , 2006/42/EC , 2014/30/EU EN 500-1:2006 +A1:2009 , EN 500-4:2011		
6 Signature	<div style="text-align: center;">  <hr style="width: 200px; margin: 0 auto;"/> </div> <div style="text-align: right; padding-right: 50px;">2nd Jun. 2022</div> <p style="text-align: center;">Keiichi Yoshida : Director, General Manager R&D Division</p>		
7 Technical documentation keeper	Engineer , R&D Division , Mikasa Sangyo Co., Ltd. 15-1,Shimoosaki,Shiraoka-city,Saitama,349-0203,Japan		
Reference data	MTX-60HDR	MTX-70HDR	MTX-80HDR
Hand-arm vibration level ※ Ahv m/s ²	5.6	4.9	4.2

※ Directive 2002/44/EC compliant. Test course (crushed gravel) is in comply with EN 500-4

Table of contents

1. INTRODUCTION	1
2. MACHINE OVERVIEW	1
3. WARNING SIGNS	2
4. CAUTIONS FOR SAFETY	2
4.1 General Cautions	2
4.2 Precautions When Adding Fuel	3
4.3 Precautions About Where To Use The Machine	3
4.4 Precautions Before Starting Work	3
4.5 Precautions While Lifting	4
4.6 Transportation And Storage Precautions	4
4.7 Maintenance Precautions	5
4.8 Decals Position	6
4.9 Decals List	6
4.10 Descriptions Of The Warning Decals	7
5. SPECIFICATIONS	8
5.1 Body	8
5.2 Engine	9
6. APPEARANCE	10
6.1 Dimensions	10
6.2 Components	11
7. INSPECTION BEFORE OPERATION	12
8. OPERATION	13
8.1 Starting	13
8.2 Operation	14
9. STOPPING THE MACHINE	15
10. STORAGE	15
11. INSPECTION AND MAINTENANCE	16
11.1 Inspection And Maintenance Schedule	16
11.2 Inspection And Maintenance Work Contents	16
12. TROUBLE SHOOTING.....	18

1. INTRODUCTION

- This operation manual describes the proper methods for using the tamping rammer, as well as simple checks and maintenance. Be sure to read this operation manual before using the rammer, in order to get full use of the excellent performance of this machine, to improve your operation and to perform work effectively.
- After reading this manual, store it in a handy location for easy reference.
- For details about the engine in this machine, see the separate operation manual for the engine.
- For inquiries about repair parts, parts lists, service manuals, and repair of the machine, please contact the shop where you purchased it, or the Mikasa Website. In addition, parts lists are available on the MIKASA website at: <https://www.mikasas.com/>

The illustrations in this manual might slightly differ in part from the machine you actually purchased due to design changes.

2. MACHINE OVERVIEW

Application

Though compact and lightweight, this rammer creates a strong impact and you may expect a large tamping effect on the ground.

It will compact nearly all types of soil, except soft soil that contains too much moisture.

Use this rammer to tamp the ground for creating roads, embankments, and to prepare the surface to support buildings. It can also be used when burying gas or water lines, and electric cables.

Warning About Incorrect Applications And Techniques

Do not use this machine on ground that is harder than the machine can handle, or for driving pilings or tamping rock beds. Furthermore, use of the machine on sloping ground such as the side of an embankment, may make the machine unstable and can cause an accident. It can also result in premature machine wear due to uneven loads on the machine.

Use the machine with confidence for tamping earth and sand, soil, sand, gravel, and asphalt. Do not use the machine for other type of jobs.

Structure

The upper section of the machine functions as a weight and consists of an engine section guide, a gear reducer section, and reciprocating section. It also accommodates the handle and the fuel tank sections, which are connected by rubber dampers.

The lower section of the machine which hits the ground, consists of a spring case to engage sliding motion, a sloping section to allow the machine to tilt toward the front, bellows to cover the foot, a sliding section, and a protective sleeve.

Power Transmission





Power is provided by an air-cooled, 4-cycle, single-cylinder gasoline engine. The output end of the engine crankshaft is equipped with a centrifugal clutch.

As the engine speed increases, the centrifugal clutch expands and a pinion gear that is a part of the clutch drum engages a gear in the crank shaft on the main frame. The engine speed is decreased in order to produce the required force for tamping.

The rotating motion of the main frame crankshaft is converted to a reciprocating motion through a connecting rod. This reciprocating motion causes the foot to go up and down through a strong coil spring. The weight of the main body and the strong force from the engine compress the spring and the foot moves up and down, striking the ground forcefully.

3. WARNING SIGNS

The triangle shaped  marks used in this manual and on the decals stuck on the machine indicate common hazards. Be sure to read and observe the cautions described.

 Warning labels indicating hazards to humans and to equipment.	
 DANGER	Denotes an extreme hazard. It calls attention to a procedure, practice, condition or the like, which, if not correctly performed or adhered to, is likely to result in serious injury or death.
 WARNING	Denotes a hazard. It calls attention to a procedure, practice, condition or the like, which, if not correctly performed or adhered to, could result in serious injury or death.
 CAUTION	Denotes a hazard. It calls attention to a procedure, practice, condition or the like, which, if not correctly performed or adhered to, could result in injury to people and may damage or destroy the product.
CAUTION (without at )	Failure to follow the instructions may result in damage to property.

4. CAUTIONS FOR SAFETY

4.1 General Cautions

WARNING

- Do not work with this machine, when
 - you are tired or sick and not feeling well.
 - you have taken medicine or drug.
 - you have had a drink alcohol.



CAUTION

- Please read the operation manual well and work safely by using the machine properly.
- For handling of the engine, please read to the attached engine operation manual.
- Please understand of the structure of this machine well.
- Make sure to do the inspection and check the machine conditions before starting operation.
- Please use protective equipment such as helmet, protective shoes, protective gloves, etc., and wear appropriate work clothes for making your work safe.
- Always wear noise protection equipment such as ear muffs or ear plugs and protective eyeglasses.
- The decals shown operation method, warning and etc. stuck on the machine are very important for your safety. Clean the machine so that the decals can be read easily. If it is difficult to read the decals, please replace with new ones.
- It is dangerous if children touch the machine. Please be careful about storage location and storage method for the machine.
- Stop the engine before maintenance work.
- We are not responsible for any accidents occurred due to the fixing without using genuine parts (foot and etc.) and equipment modifications.



4.2 Precautions When Adding Fuel

DANGER

- When adding fuel.
 - Be sure to work in a well ventilated location.
 - Be sure to work in a clear and flat location without any combustibles nearby.
 - Be sure to stop the engine and wait until it has cooled down.
 - Do not use any flames (smoking and etc.) while adding fuel.
 - Do not overfill tank. If you spill some fuel, wipe it all up.
 - Tighten the tank cap securely after adding fuel.



4.3 Precautions About Where To Use The Machine

DANGER

- Do not run the engine in any enclosed or narrow area, such as indoors or in a tunnel. Engine exhaust gases contain poisonous carbon monoxide. This gas is colorless and odorless, and can cause death if inhaled.
- Do not operate the machine near flames.



4.4 Precautions Before Starting Work

CAUTION

- If you use the machine for a long time, be careful to watch for signs of vibration syndrome. Since this machine vibrates, work for a long time may have a negative effect on your body. Take sufficient breaks while working.
- Before starting to operate the machine, check the safety for people around and obstacles nearby.
- When starting the engine, the rammer may jump suddenly. Hold the handle firmly and then pull the recoil starter.
- Always be careful around ground condition at job site. Operate the rammer in stable position and balance.
- Keep your foot away from the foot of the rammer during work. The foot of the rammer may crush your foot.
- Do not touch the muffler, muffler cover and main body of the engine during work or soon after work, because they are very hot.
- If you find trouble or damage of the machine during work, stop work immediately. Before leaving or moving the machine, be sure to stop the engine.
- When lifting the rammer with the handle, be careful not to pinch your fingers between the handle and main body.
- Push down the rear end of the handle as shown in the left figure (A) and check that there is no damage on the shock absorbers. If it found the damaged shock absorbers, replace them with new ones by left and right set.

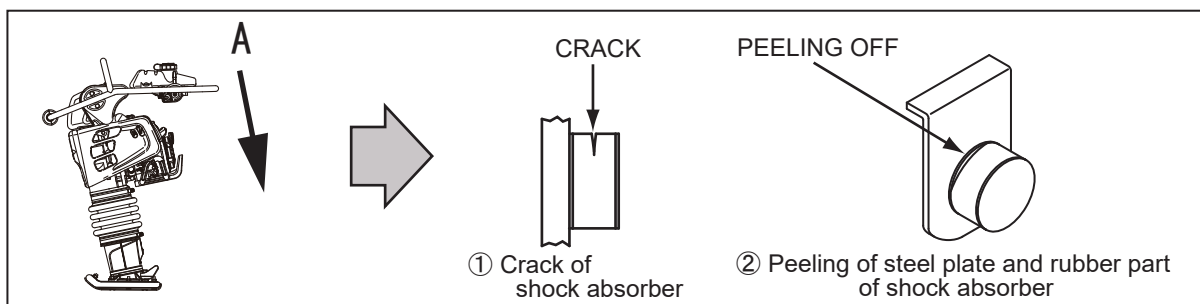

DANGER

- Take the utmost care not to tip over the rammer during work, stored or stopped. Tie down the rammer with cable (wire or rope) when stopped or stored so that it cannot tip over.
- If the rammer tips over when children are nearby, they may have a serious accident.
- If the foot of the rammer is worn, the rammer will be especially unstable.
- If the foot of the rammer is severe worn, replace it with new one.
- If the rammer falls over during work, it will move to forward due to kicking motion of the foot while falling over. And if the ground is solid, the rammer will move quickly so it is very dangerous. After ensuring that the operator and people around are safe, move the throttle lever to the engine stop position and make sure the rammer stops.
- Take careful note of safe especially when working on the public road, because a serious accident can occur easily.



4.5 Precautions While Lifting

DANGER

- Before lifting the machine, make sure that there is no damage to parts on the machine (especially the shock absorber and the hook), loosening or missing of the bolt, and the machine must be in a safe condition.
- Stop the engine before lifting the machine.
- Use adequate lifting cable (wire or rope) of sufficient strength for support to the machine.
- Do not lift it higher than necessary for safety.
- Do not use a damaged lifting cable.
- Use one point lifting hook for lifting the machine and lift straight upwards. Do not use any other points (such as the handle) for lifting.
- Never lift or lower the machine rapidly with hydraulic excavator.
- Never allow any person or animal to stand underneath the machine while lifting.
- Be careful not to an accident when using any lifting equipment. Before using the lifting equipment, make sure that there is no trouble or damage.

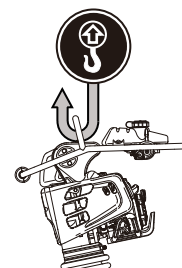

4.6 Transportation And Storage Precautions

DANGER

When transporting

- Before transporting the machine, stop the engine.
- **DO NOT** try to move it before the engine and machine body have cooled down enough.
- Drain any fuel before transporting the machine.
- Transport the rammer in a manner that keeps it level. If you must lay the machine down to transport it, drain any fuel from the fuel tank and carburetor. Then close the fuel tank cap and oil fill plug securely. Next, position the machine so that the air cleaner will be facing up.
- Tie down the machine body so that the machine cannot move or fall during transportation.
- When you want to lift the machine by gripping the handle, be careful not to pinch your fingers or hands between the handle and the main body.
- Since this machine is quite heavy, use a truck specifically designed to transport heavy objects.

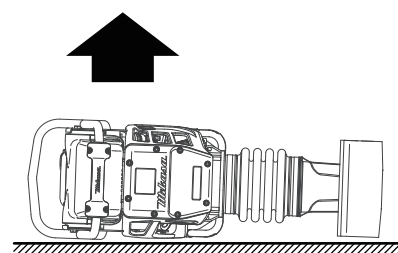

When storing the machine

- After the engine and machine body have cooled down enough, store the rammer so that it is level. Tie down the machine as needed so that the machine cannot fall down. If you must lay the machine down, close the fuel tank cap and oil fill plug securely. Arrange the machine position so that the carburetor will be facing up. After it lays down, make sure there are no oil or fuel leaks. (If fuel is leaking, drain it all from the fuel tank.)

4.7 Maintenance Precautions

WARNING

- Ensure safety for maintenance. It needs appropriate maintenance for keeping the machine performance. Keep the machine in good condition with attention to the machine's condition always.

CAUTION

- Be sure to stop the engine before maintenance of the machine.
- Do not touch the muffler, muffler cover and main body of the engine until they have cooled down enough to prevent burn.
- Do not touch the lubrication oil and engine oil until they have cooled down enough to prevent burn.
- When maintenance of the machine with disassembling, be sure to refer the service manual and always work safely.
- After maintenance of the machine, check that the parts are assembled properly and machine conditions for safety.



4.8 Decals Position

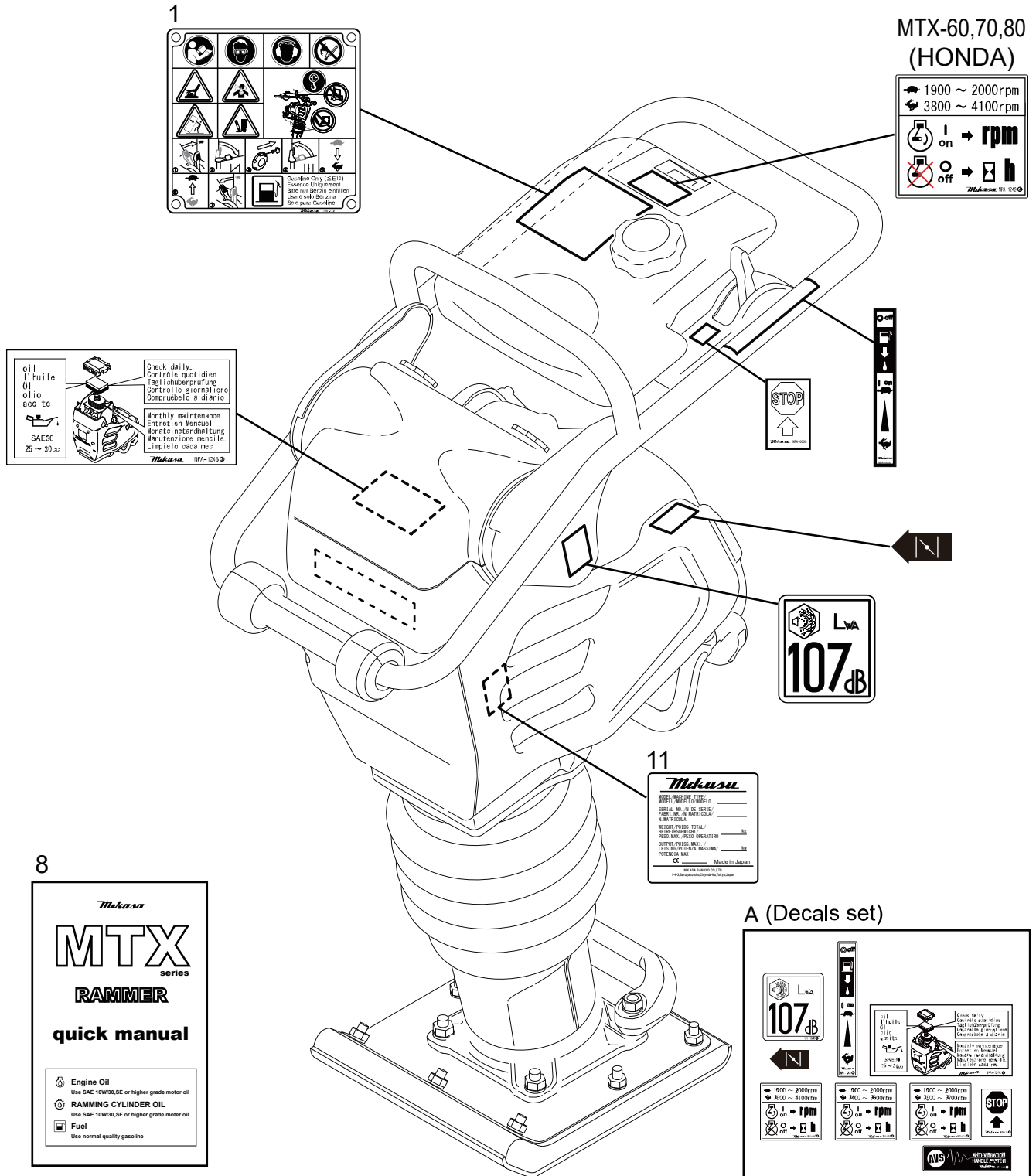

4.9 Decals List

No.	Part No.	Part Name	Remarks
A	9209-00042	DECAL,SET/MTX/MQ,EXP	
1	9202-15440	DECAL,OPERATION/MTX/EVP	
8	9202-12540	QUICK MANUAL / MTX	
11	9202-17010	PLATE,SERIAL NO. MTX SERIES	

4.10 Descriptions Of The Warning Decals

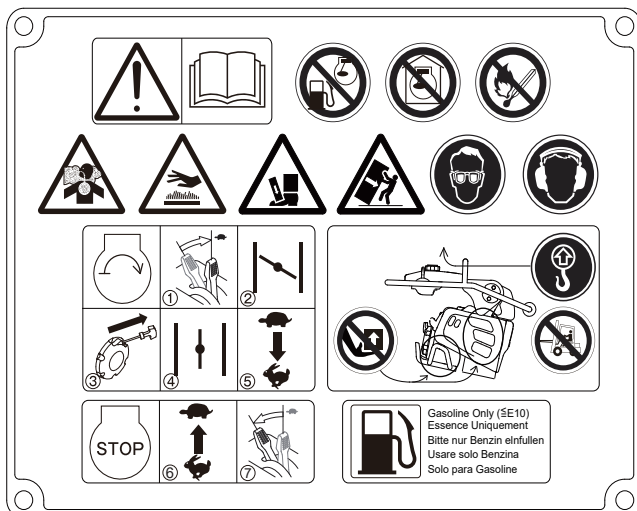

Lethal Exhaust Gas Hazard.
Carbon monoxide poisoning may occur if the exhaust gas is inhaled. Do not operate the machine in a poorly ventilated area.



Crush hazard.
Keep your foot away from the machine during operation. The plate of machine may crush your foot.



Eye hazard.
Always wear eye protection while operating the machine.



Lifting position.
Use one point lifting hook for lifting the machine.



Lifting with a forklift is prohibited.



Read the manual carefully.
Read and fully understand the operation manual before operating the machine.



Refueling Hazard.
Stop the engine and let cool before refueling.



Do not operate the machine in a poorly ventilated area.



Fire hazard.
Keep away any flames and sparks from the machine.



Burn hazard.
Never touch the hot parts. Allow these parts to cool before servicing the machine.



Tip over hazard.
Take the utmost care not to tip over the machine during operation, storage or stop.



Noise hazard.
Always wear ear protection while operating the machine.





Lifting the machine by the engine guard is prohibited.



Fuel specification (gasoline)

Starting and Running

- ① Move the throttle lever to the “on (|)  ” position.
Engine switch: ON
Fuel Valve: OPEN
Engine speed: Idling speed
- ② Move the choke lever to the “CLOSED” position.
- ③ Pull the recoil starter handle.
- ④ Move the choke lever to the “OPEN” position.
- ⑤ Move the throttle lever to the “ ” operating position.

Stopping

- ⑥ Move the throttle lever to the “on (|)  ” position.
- ⑦ After the machine has cooled down, move the throttle lever to the “of (STOP)” position.
Engine switch: OFF
Fuel Valve: CLOSED
Engine speed: STOP



5. SPECIFICATIONS

5.1 Body

Model			MTX-50E	MTX-60E/FE	MTX-60HDR
Dimensions	Overall height		1025 (1029)	1025 (1026)	1025
	Overall width	mm	350	350	350
	Overall length		713 (694)	713 (694)	713
Plate Size	Length	mm	340		
	Width		265		
Fuel Tank Capacity		L	2.5		
Rammer Body Oil Grade			API SE or later SAE 10W-30		
Rammer Body Oil Capacity		cc	350	650	
Number of Blow		Hz/v.p.m	10.7~11.6/644~695		
Impact Force		kN/kgf	10.3/1,050	13.6/1,390	
Jumping Stroke		mm	40~70	50~80	
Operating Weight		kg	60	64	
Engine Model			GX100 RAMMER		GXR120 RAMMER

Model			MTX-70E/FE	MTX-70HDR	MTX-80HDR
Dimensions	Overall height		1027 (1032)	1027	
	Overall width	mm	350	350	
	Overall length		788 (758)	788	
Plate Size	Length	mm	340		
	Width		285		
Fuel Tank Capacity		L	2.5		
Rammer Body Oil Grade			API SE or later SAE 10W-30		
Rammer Body Oil Capacity		cc	820		
Number of Blow		Hz/v.p.m	10.7~11.6/644~695		
Impact Force		kN/kgf	14.9/1,520	15.6/1,590	
Jumping Stroke		mm	50~80		
Operating Weight		kg	75	82	
Engine Model			GX100 RAMMER	GXR120 RAMMER	

※ The numbers shown in parentheses are the dimensions with "High height handle".

※ Specifications are subject to change without notice.

5.2 Engine

Model		Honda GX100 RAMMER
Type		Air-Cooled 4 Stroke, OHC Single cylinder gasoline engine.
Caburetor System		Diaphragm type (E) / Float type (FE)
Piston Displacement	cc	98
Max. Output *	kW(PS)/rpm	2.1(2.9)/3600
Fuel		Unleaded Gasoline
Engine Oil Grade		API SJ or later SAE 10W-30
Engine Oil Capacity	cc	280
Starting System		Recoil starter
Engine Operating Speed	rpm	3800 – 4100

※ Based on "SAE J1349"

Model		Honda GXR120 RAMMER
Type		Air-Cooled 4 Stroke, OHC Single cylinder gasoline engine.
Caburetor System		Diaphragm type (HDR)
Piston Displacement	cc	121
Max. Output *	kW(PS)/rpm	2.7(3.6)/3600
Fuel		Unleaded Gasoline
Engine Oil Grade		API SJ or later SAE 10W-30
Engine Oil Capacity	cc	280
Starting System		Recoil starter
Engine Operating Speed	rpm	3800 – 4100

※ Based on "SAE J1349"

6. APPEARANCE

6.1 Dimensions

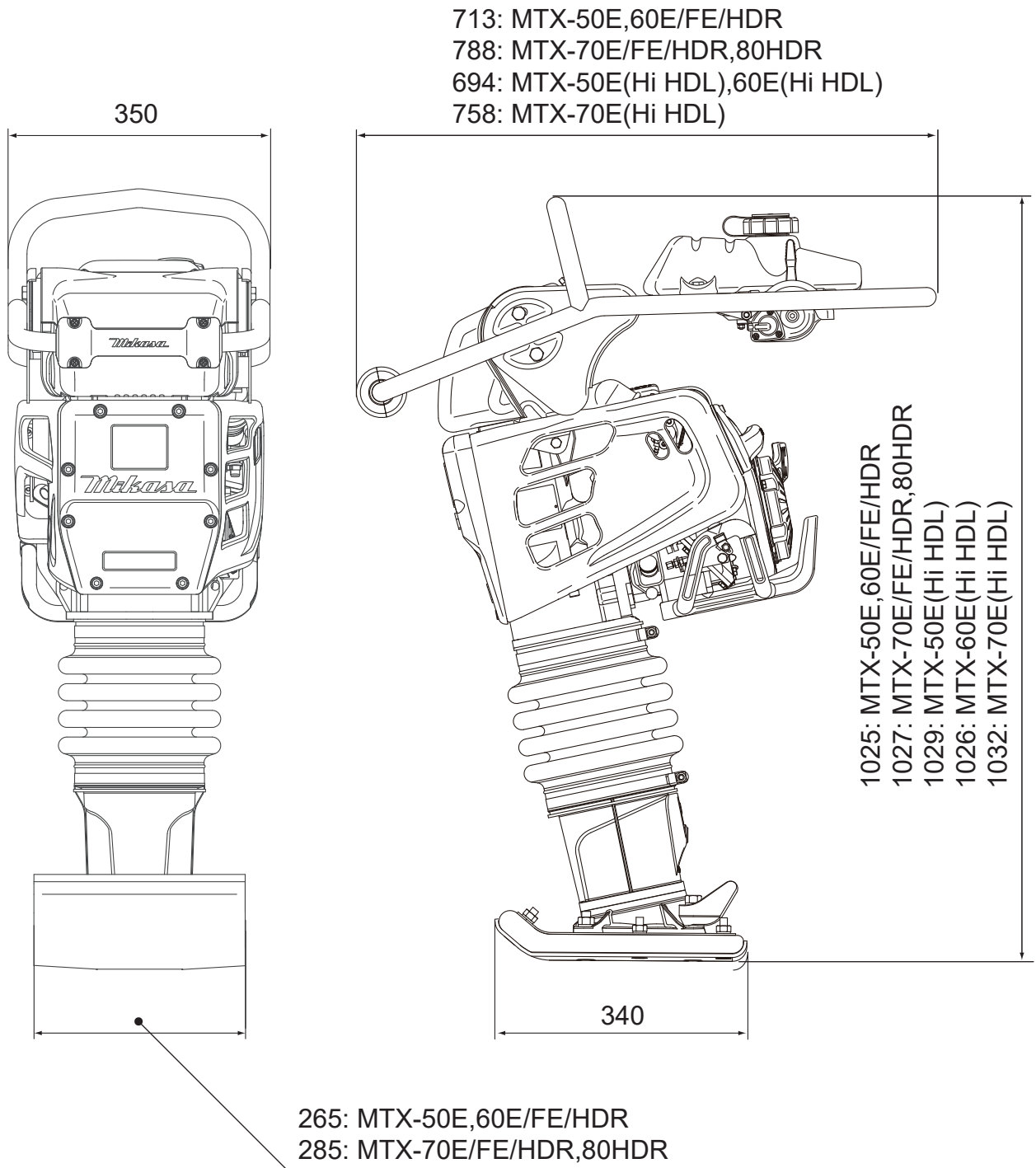

※ Specifications are subject to change without notice.

6.2 Components

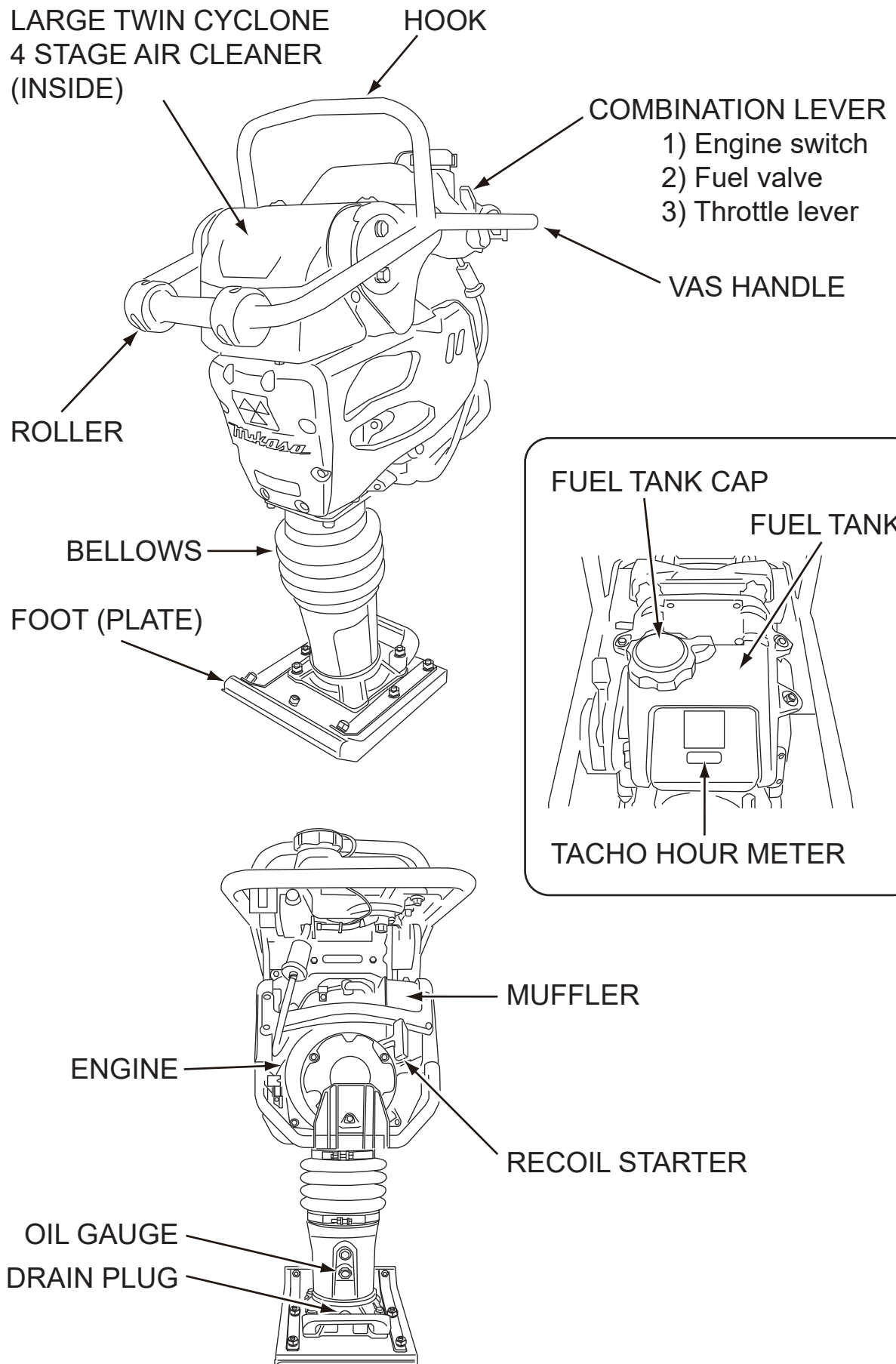

7. INSPECTION BEFORE OPERATION

⚠ WARNING

- Only check the machine while the engine is stopped. Otherwise, you may be caught by the rotating components and be seriously injured.
- Check the machine body only after it has cooled down. The muffler is very hot and you may be badly burned.



Inspection points	Inspection items
Appearance	Flaws, deformity, stains
Air cleaner	Stains, flaws, deformation
Bolts, nuts	Loose or missing parts
Handle	Flaws, deformity, cracks, breaks
Rubber damper	Flaws, deformity, cracks, breaks
Engine oil	Leaks, oil level, dirt
Main body lubrication oil	Leaks, oil level, dirt
Fuel tank	Leaks, fuel level, presence of dirt
Fuel system	Leaks, wear, loose parts

1. Clean each components thoroughly so that there is no mud or dirt on it. In particular, remove any mud on the machine foot, and clean the area around the recoil starter and carburetor.
2. Make sure that all of the screws are tight. Loose screws may cause an accident due to the vibration.
3. To check the engine oil, place the machine on a level surface (The engine remains in an inclined state.). (Fig.1)
For details about the engine, see the separate operation manual for the engine.

- Oil type: API SJ or later SAE 10W-30
- Oil amount: 280cc

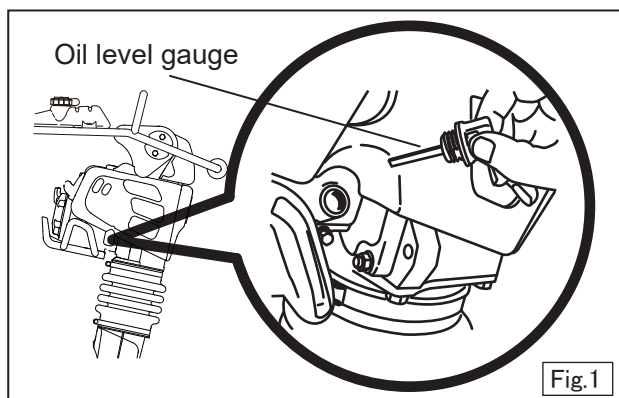

Fig.1

⚠ WARNING

Add the engine oil before it gets too low. Too little engine oil may cause the engine to wear prematurely.

4. Place the machine on a level surface, and visually check at the oil gauge on the protect sleeve from horizontal direction, if the oil is at the specified level. (Fig.2)

- Oil type: API SJ or later SAE 10W-30
- Oil amount:
MTX-50: 350cc
MTX-60: 650cc
MTX-70/80: 820cc
- Tightening torque:
Oil level plug : 39.2N·m (400kgf·cm)
Drain plug : 49.0N·m (500kgf·cm)

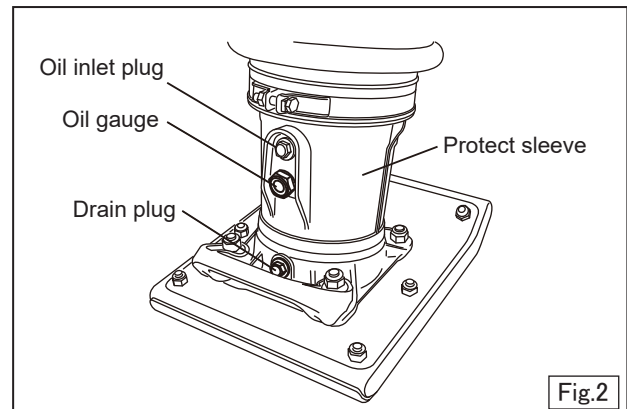

Fig.2

5. Before using, be sure to retighten each nuts for foot mounting. (Fig.3)

- Tightening torque:
Nut M10 : 29.4N·m (300kgf·cm)
Nut M12 : 78.4N·m (800kgf·cm)

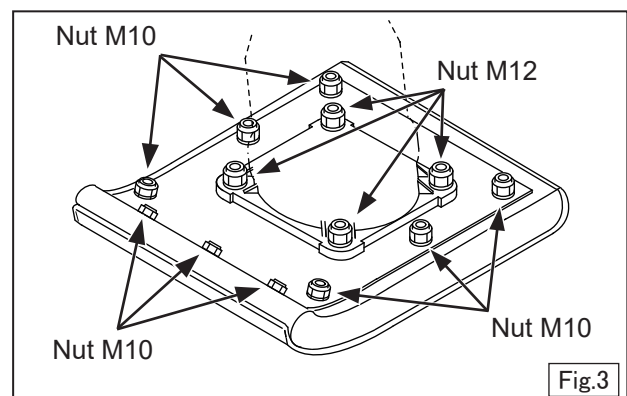

Fig.3

6. Visually check fuel level. If fuel level is low, refuel with unleaded fuel. (Fig.4)
When refueling, be sure to use a strainer for filtration.

⚠ DANGER

Fire hazard while refueling.

⚠ CAUTION

If any fuel spills, wipe it all up.

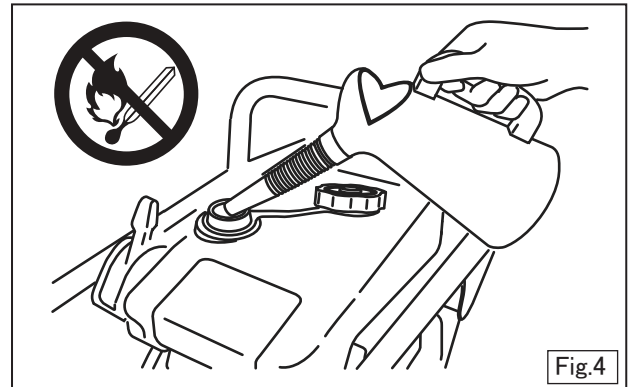

Fig.4

8. OPERATION

8.1 Starting

1. Move the throttle lever from the stop to the idling position (→). That opens the fuel cock and the engine switch turned on automatically. (Fig.5)

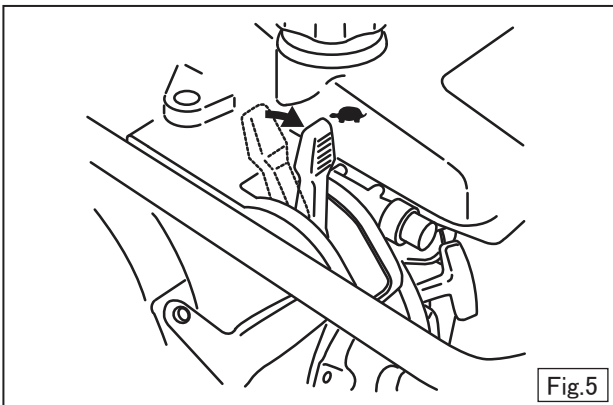
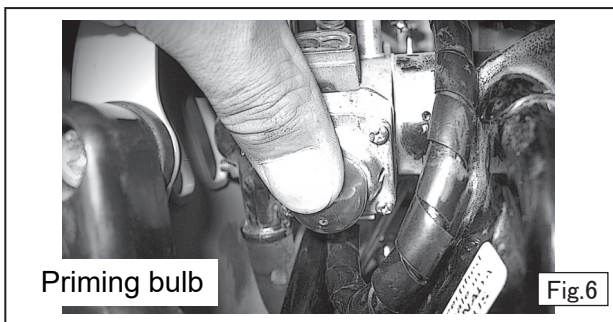

Fig.5

Diaphragm carburetor with Priming bulb

Push the bulb at Primer Pump several times, which delivers fuel to the carburetor forcibly. (Fig.6)



Priming bulb

Fig.6

2. Move the choke lever on the carburetor to the closed position. When it is cold, close the choke all the way. When it is hot, such as in the summer, or when the engine is already hot, open the choke a little or leave it fully open. (Fig.7-1, 7-2)

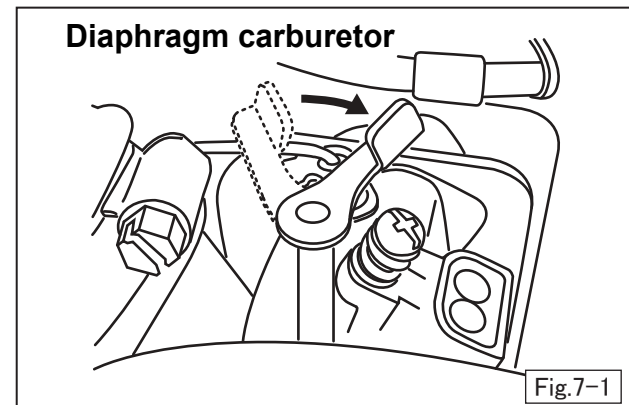

Fig.7-1

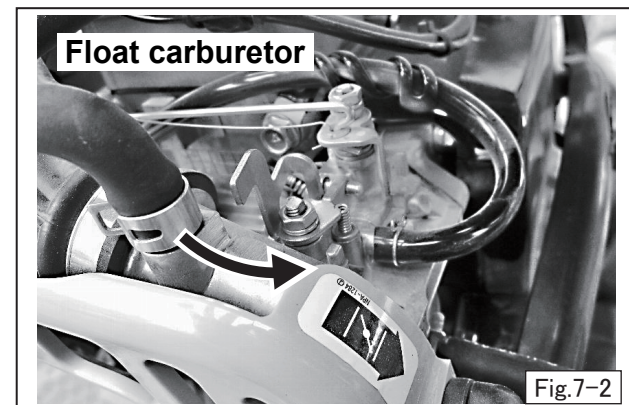

Fig.7-2

3. Hold the recoil starter handle and pull it a little. You will feel resistance. Then, pull it hard to turn the engine. Allow the starter rope to return slowly into the case before letting go of the handle. (Fig.8)

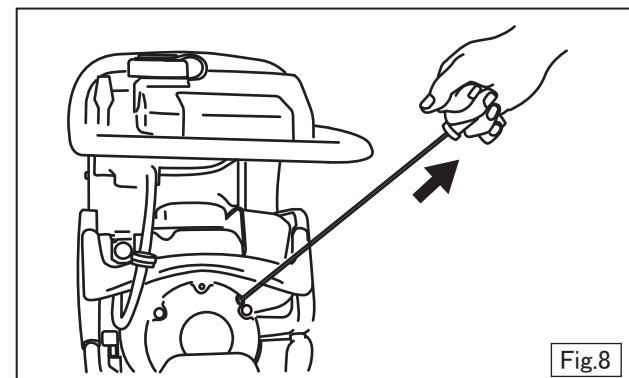

Fig.8

- After the engine has started, open the choke lever gradually until it is wide open. Pay attention to the sound of the engine to guide you in the amount to open the choke. After the engine has started, be sure to warm up the engine at low speed for 3 to 5 minutes. During this time, check the machine for leaking fuel, abnormal sounds, or abnormal exhaust color or odor.

⚠ WARNING

When warming up, note the engine speed to prevent the clutch slipping.

- If the engine cannot be started after pulling the starter handle several times, it may cause the flooded engine (Spark plug wet.). Dry and reinstall the spark plug. While the plug is removed, pull the starter handle 2 to 3 times to discharge any fuel from the cylinder. Start the engine with throttle lever in MAX. position, with choke lever in OPEN position.

8.2 OPERATION

- Move the throttle lever from idling (☛) to the operating position (☞) quickly (Fig. 9) and the tamping rammer will start up and down motions. Moving the throttle lever slowly will cause irregular operation and damage the clutch, springs, and foot.

⚠ CAUTION

In case of moving the throttle lever from idling to operating position too quickly, the engine may stop due to not follow response of the carburetor.

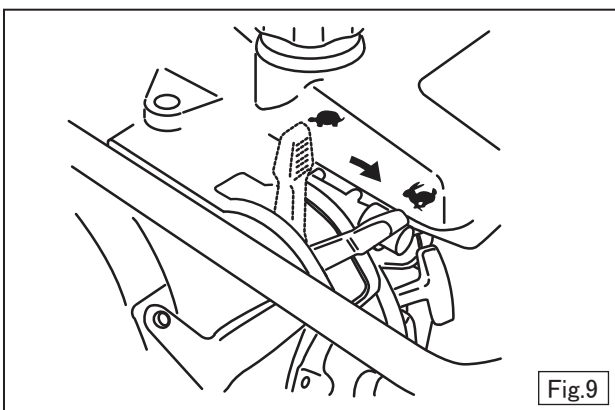

- After operation is started, adjust the throttle lever a little until the rammer tamps the soil correctly. When the engine is running within the specified rpm range, the rammer will be the most effective. If the engine runs too fast, the tamping force will not be increased. Instead, the spring resonance will decrease the tamping force and damage the machine.

⚠ WARNING

If the rammer is used on sloping ground, check the safety of the surroundings and be careful not to allow the machine to tip over.

- In the cold season, the oil in the machine will be thicker, and the resistance of the components will be much larger, which may cause irregular motion. Shift the throttle lever from the operating to the idling position several times and allow it to warm up sufficiently before starting actual work.
- The surface of the foot in contact with the ground is a metal sheet that has excellent wear resistance. However if you need to tamp ground that contains large stones (about the size of a fist), first put some fill soil over them so that the foot will tamp the ground evenly.
- The machine body will advance as it jumps. If you want to move forward faster, push the handle a little forward to make the machine body lean a little forward.
- To halt work, quickly move the throttle lever from the operating position (☞) to the idling position (☛). Do not move the throttle lever slowly. (Fig.10)

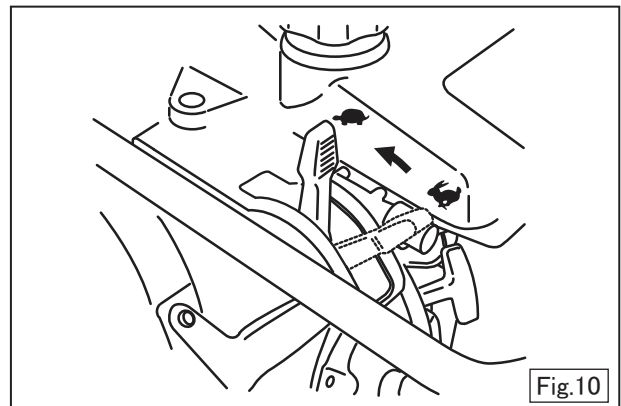

9. STOPPING THE MACHINE

1. Move the throttle lever from the operating position (↻) to the idling position (↻). Run the engine at low speed for 3 to 5 minutes to cool it down. Then move the throttle lever from the idling position to the stop position. The engine will stop and the fuel cock is closed automatically. (Fig.11)
2. If the engine does not stop due to a problem with the switch or something similar, put the machine to a safe location and hold the throttle lever in the stop position. Let the machine run in idling and the engine will stop due to out of fuel.

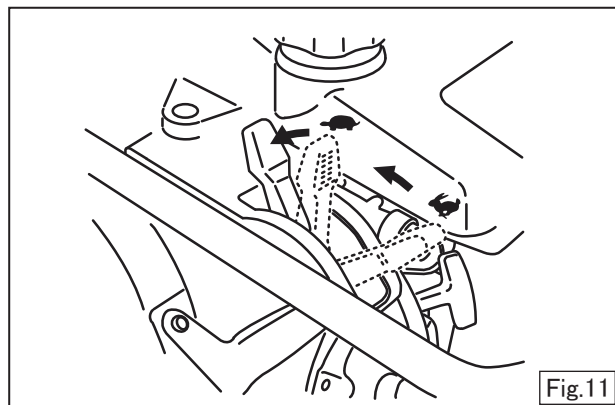

10. STORAGE

1. Wash off any dirt or mud on each part of the machine using fresh water. After the engine and main body have cooled down, store the rammer on a level location.
2. Maintain upright position of the rammer on a level location during storing, tie down it to prevent tip over.
3. In case of laying down the rammer, lay down it with the air cleaner facing up, and close the fuel tank cap securely and tighten engine oil drain plug. (Fig.12)
4. Avoid storage areas with high temperature and high humidity, or environments with severe temperature changes. Keep away from direct sunlight and rain.
5. Put a cover on the machine to avoid depositing dirt.
6. When transporting the rammer, drain any fuel from the fuel tank and carburetor.
7. The rammer position during transport is the same as 2 and 3 for the storage as above.
8. For prolonged storage
 - Move the throttle lever to the idle position.
 - Drain any fuel and change the lubrication oil. Be sure to remove any fuel in the fuel hose, too.
 - Cover the air intake on the air cleaner and the exhaust outlet on the muffler.
 - Store the machine indoor. Do not leave it outside.

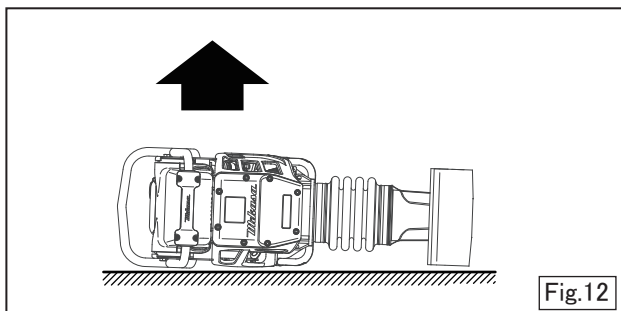

11. INSPECTION AND MAINTENANCE

⚠ WARNING

- Only check the machine while the engine is stopped. Otherwise, you may be caught by the rotating components and be seriously injured.
- Check the machine body only after it has cooled down. The muffler is very hot and you may be badly burned.



11.1 Inspection And Maintenance Schedule

Inspection interval	Inspection parts	Inspection items	Remarks
Daily (before starting operation)	Appearance	Deformation, Breakage, Crack, Dirt	
	Air cleaner	Dust, Dirt, Deformation	
	Bolts, nuts	Loose or missing parts	
	Handle	Deformation, Breakage, Crack	
	Shock absorber	Deformation, Breakage, Crack	
	Engine oil	Leaks, Oil level, Dirt	Engine oil
	Main body lubrication oil	Leaks, Oil level, Dirt	Engine oil
	Fuel tank	Leaks, Fuel level, Dirt	Gasoline
	Fuel system	Leaks, Wear, Loose parts	
After first 20 hours	Engine oil	Change once after the first 20 hours.	Engine oil
Every 50 hours	Spark plug	Cleaning, Adjust gap	
	Fuel filter	Cleaning	
Every 100 hours	Engine oil	Change	Engine oil
	Air cleaner element (Primary)	Cleaning	Kerosene, Engine oil (25-30cc)
Every 150 hours	Air cleaner element (Secondary)	Cleaning	Neutral detergent (water washing and dry)
Every 200 hours	Main body lubrication oil	Change (First change at 50 hours)	Engine oil
Every 2 years	Fuel hose	Change	
	Intake pipe	Change	

For details about the check and maintenance of the engine, please refer to the attached engine operation manual.

⚠ CAUTION

- The above table shows the check frequency for standard condition.
- The check frequency may vary depending on the condition in which the machine is used.

11.2 Inspection And Maintenance Work Contents

1. Daily maintenance

Carefully wipe off any mud, dirt or oil from each component.
If oil leaks, retighten the joints and check again.

2. Maintenance after every 50 hours of operation

Remove the fuel filter cup and clean the inside thoroughly. (Fig.13)
Remove the spark plug and clean it. Then adjust the gap to 0.6 to 0.7 mm.

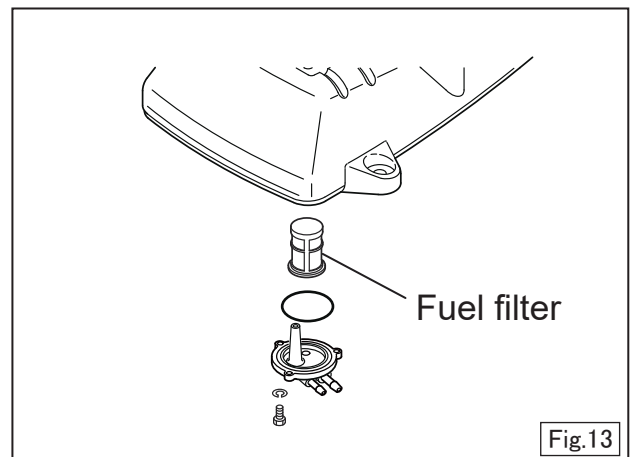

3. **Cleaning the air cleaner**

Remove the upper air cleaner cover on the main body. Loosen and remove the 2 Phillips screws that hold the cover on the air cleaner assembly.

a. **Primary element**

(clean every 100 hours)

If the primary element is dirty, wash it with gasoline or kerosene. Then, add 25 to 30cc of the engine oil SAE10W-30 to it and impregnate evenly by squeezing lightly. (Fig.14)

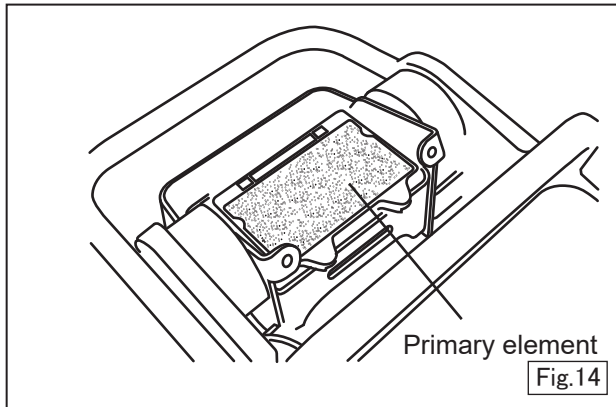

b. **Secondary element**

(clean every 150 hours)

If the secondary element (Fig.15) under the primary element is dirty, wash it with neutral detergent and dry it well. Then reuse it. (Fig.16)

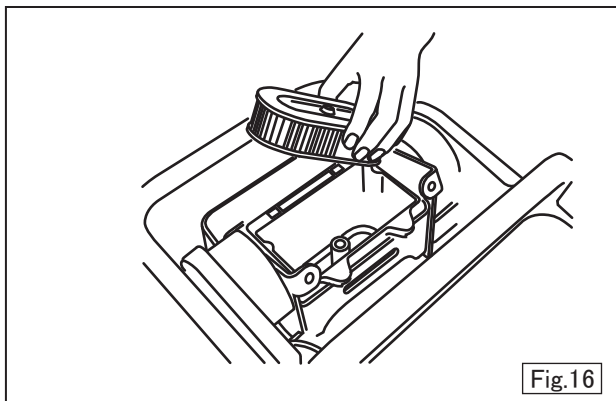
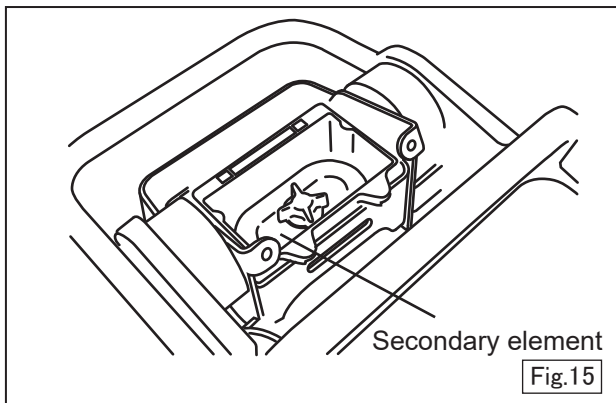

4. **Main body lubrication oil** **(change every 200 hours)**

Remove the drain plug on the lower part of the machine body and drain the oil. Then add the specified amount of new oil. (Fig.17)

Model	MTX-50	MTX-60	MTX-70	MTX-80
Capacity (liters)	0.35	0.65	0.82	0.82

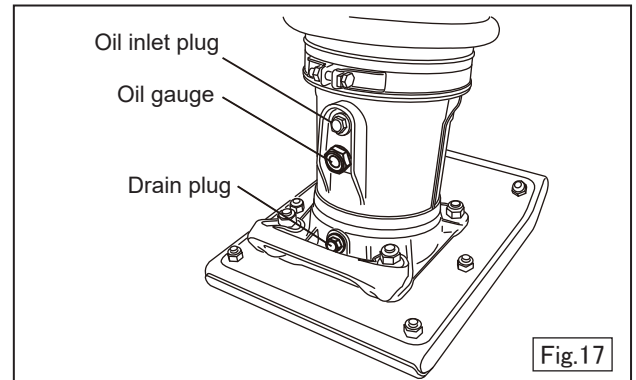

5. **Be sure to check the fuel line for damaged or looseness.**

Change the fuel line every 2 years, even if it does not show any abnormality.

CAUTION

Cleaning the machine body

If you want to clean the machine body using high-pressure steam, do not spray water directly into the air cleaner, carburetor, muffler, or top of the fuel tank. Otherwise engine problems may occur.

12. TROUBLE SHOOTING

Engine

1. Won't start

Fuel is present but the spark plug is not sparking.	Electricity is being supplied to the high voltage cable.	The gap in the spark plug tip is clogged. Carbon is stuck on the spark plug The spark plug has a short circuit due to faulty insulation. The gap in the spark plug is the wrong size.
	Electricity is not being supplied to the high voltage cable	The stop button switch has a short circuit. The ignition coil is broken.
Fuel and spark are both present.	Compression is good	The muffler is clogged with carbon. The wrong fuel was used. The air cleaner is clogged. The fuel is contaminated with water or dirt. The cylinder head gasket is blown or the head is not correctly tightened.
	Compression is low	The piston rings don't fit well. The cylinder is worn. The spark plug is not seated tightly. The valve seat is damaged.
Fuel is not being supplied to the carburetor.	No fuel in the fuel tank. Faulty fuel cock operation. The fuel filter is clogged. The air hole in the cap on the fuel tank is clogged. Air is trapped in the fuel line.	

2. Faulty operation

Too little power	Good compression and no misfiring		Dirt in the air cleaner. Air trapped in the fuel line. Carbon has accumulated in the cylinder.
	Low compression (See "Compression in low" above)		
	Good compression but misfires		Faulty ignition coil. Dirt on the spark plug. Ignition coil shorts sometimes.
Engine overheats	Excessive accumulation of carbon in the combustion chamber. Clog exhaust port or muffler. Faulty spark plug.		
Smoke comes from the muffler	Black smoke		Choke lever wasn't returned to the open position.
	Blue smoke	Good compression	Blended oil (for 2-cycle engines) was used. Too much oil. Engine oil leaked into the air cleaner when the machine was laid down on the wrong side.
		Compression is low	Worn piston rings. The piston rings don't fit well.
White smoke		Moisture in the gasoline. The air cleaner is wet.	

(In the winter, the machine may emit white smoke for a while when first started in the morning. This is not abnormal.)

Engine speed fluctuates	Faulty governor adjustment. Faulty governor spring. Faulty fuel flow. Air being sucked into the fuel line.
-------------------------	---------------------------------------------------------------------------------------------------------------------

Mikasa

MIKASA SANGYO CO., LTD.

1-4-3, Kanda-Sarugakucho, Chiyoda-ku, Tokyo, 101-0064, Japan

PRINTED IN JAPAN