

# Mikasa

POWER DRIVE UNIT

# GE-5LH

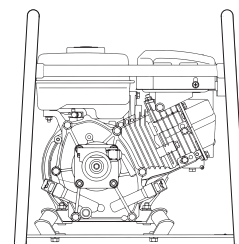

## OPERATION MANUAL

en



<http://www.mikasas.com>

202-01602



## EC Declaration of Conformity

1 Manufacturer's name and address	<b>Mikasa Sangyo Co., Ltd.</b> 1-4-3, Kanda-Sarugakucho, Chiyoda-ku, Tokyo, 101-0064, Japan
2 Description of the equipment	Power Generators ( Drive Units )  GE-5LH  —  95  105  Air cooled , 4 stroke SI engine ( Honda GX160 ) : 3.6 kW
2.1 Product	
2.2 Type	
2.3 Version(s)	
2.4 Measured sound power level    dB(A)	
2.5 Guaranteed sound power level   dB(A)	
2.6 Motor type : Net power	
3 Conformity assessment procedure	Annex VIII of 2000/14/EC as last amended by 2005/88/EC
4 Notified Body's name and address	TÜV Rheinland LGA Products GmbH Tillystraße 2, 90431, Nürnberg, Germany Notified Body number: NB 0197
5 Comply with relevant provisions and requirements of the following directives and standards	2000/14/EC , 2006/42/EC , 2014/30/EU EN 500-1:2006 +A1:2009 , EN 500-4:2011
6 Signature	 _____ Keiichi Yoshida : Director, General Manager R&D Division
7 Technical documentation keeper	Engineer , R&D Division , Mikasa Sangyo Co., Ltd. 15-1,Shimoosaki,Shiraoka-city,Saitama,349-0203,Japan
Reference data	—
Hand-arm vibration level ※    Ahv    m/s <sup>2</sup>	—

※ Directive 2002/44/EC compliant. Test course (crushed gravel) is in comply with EN 500-4

# TABLE OF CONTENTS

1. INTRODUCTION .....	1
2. MACHINE OVERVIEW .....	1
3. WARNING SIGNS .....	2
4. CAUTIONS FOR SAFETY .....	2
4.1 General Cautions .....	2
4.2 Refueling Precautions .....	3
4.3 Location And Ventilation Precautions .....	3
4.4 Precautions Before Starting .....	3
4.5 Precautions During Work .....	3
4.6 Lifting Precautions .....	3
4.7 Transportation And Storage Precautions .....	4
4.8 Maintenance Precautions .....	5
4.9 Decals Position And Descriptions Of Warning Decals ....	5
5. SPECIFICATIONS .....	5
6. APPEARANCE .....	6
6.1 Dimensions .....	6
6.2 Components .....	6
7. INSPECTION BEFORE OPERATION .....	7
7.1 Visual Inspection .....	7
7.2 Engine Oil .....	7
7.3 Refueling .....	7
7.3 Work Location .....	7
8. OPERATION .....	7
8.1 Starting .....	7
8.2 Operation .....	8
9. STOPPING THE MACHINE .....	9
10. STORAGE .....	9
11. INSPECTION AND MAINTENANCE .....	10
12. TROUBLESHOOTING .....	11

## 1. INTRODUCTION

- This operation manual describes the proper operation, basic inspection and maintenance procedures of the reversible compactor. Please read this operation manual before use in order to maximize the excellent performance of this machine and make your work more efficient and effective.
- After reading the manual, please keep it in a handy location for easy reference.
- For the handling the engine, please refer to the separate engine operation manual.
- For inquiries about repair parts, parts lists, service manuals, and repairs, please contact the store where you purchased the product, our sales office, or the Mikasa Parts Service Center. For parts lists, please visit our homepage at: <http://www.mikasas.com/> where you can access Mikasa WEB parts lists.

The illustrations in this manual might slightly differ in part from the machine you actually purchased due to design changes.

## 2. MACHINE OVERVIEW

### Application

This product is an engine type motor for GH series pendulous type vibrator for concrete compaction using a flexible shaft and for WP series underwater pump that works by impeller rotation. This product is used for concrete casting and water pumping by connecting it to the work machine via its coupling part.

### Warning About Incorrect Applications And Techniques

Do not connect this product to work machines not specified for this product. If the part to be connected to a work machine is altered or this product is connected to a machine having a connection part that does not fit, the connection part will either get stuck or fall off during operation, resulting in damage of this product or the work machine. Also, do not operate with the engine revolution raised above the specified level, because that might accelerate damage of this product and the work machine and there is a potential risk of operator injury by dispersion of broken part pieces.

### Structure





The engine is installed either directly on the base or via the shock absorbers. There are two types for the base that has an integrated frame, with one type being placed directly on the ground and the other placed on a rotary table for free rotation.

### Power Transmission

To the output shaft of the engine, a socket with a hexagonal hole is attached. This will be used as a guide when connecting this product to a work machine, and a coupling flange with a lever to prevent falling off is fixed on the engine. If the lever is turned to the direction opposite to the spring back force, such falling off prevention mechanism will be cancelled, enabling the work machine to be disconnected. Power is transmitted to the work machine when the rotation of the hexagonal hole of the socket attached to the engine output shaft turns the work machine's hexagonal joint inserted to the hexagonal hole.

### 3. WARNING SIGNS

The triangle shaped  marks used in this manual and on the decals stuck on the main body indicate common hazards. Be sure to read and observe the cautions described.

 <b>Warning labels indicating hazards to humans and to equipment.</b>	
 <b>DANGER</b>	Denotes an extreme hazard. It calls attention to a procedure, practice, condition or the like, which, if not correctly performed or adhered to, is likely to result in serious injury or death.
 <b>WARNING</b>	Denotes a hazard. It calls attention to a procedure, practice, condition or the like, which, if not correctly performed or adhered to, could result in serious injury or death.
 <b>CAUTION</b>	Denotes a hazard. It calls attention to a procedure, practice, condition or the like, which, if not correctly performed or adhered to, could result in injury to people and may damage or destroy the product.
<b>CAUTION</b> (without at  )	Failure to follow the instructions may result in damage to property.

### 4. CAUTIONS FOR SAFETY

#### 4.1 General Cautions

##### **WARNING**

- Do not work with this machine, when
  - you are tired or sick and not feeling well,
  - you have taken medicine or drug, or
  - you have had a drink.



##### **CAUTION**

- Please read the operation manual well and work safely by using the machine properly.
- For handling of the engine, please refer to the separate engine operation manual.
- Please have a good understanding of the structure of this machine.
- Make sure to do work start inspection, regular self inspection and specified self inspection.
- To make your work safe, please use protective equipment (use specified helmet, protective shoes, etc.) and wear appropriate work clothes.
- Always use noise protection equipment such as ear muffs or ear plugs.
- Always check the machine to make sure it is in normal condition before operating the machine.
- The nameplates attached to the machine (nameplates showing operation method, warning, etc.) are very important for your safety. Clean the machine so that the nameplates can be read easily. If it is difficult to read the nameplate, please replace the old one with a new one.
- It is dangerous for young children to come near the machine. Please pay careful attention to the method of storing and the storage location for this machine. Especially the engine start key has to be taken out every time you finish your work, and keep it in a designated location.
- To do maintenance work, stop the engine and remove the battery wiring.
- We are not responsible for accidents that have occurred after the machine was refurbished without approval from the manufacturer.



## 4.2 Refueling Precautions

### **DANGER**

- Always refuel in a well ventilated area.
- Make sure to stop the engine and wait until the engine cools down when refueling.
- Select a flat surface area with no flammable material around for refueling. Be careful not to spill the fuel. Wipe off well if there is any spill.
- Never put fire near the machine during refueling. (Especially, be careful about smoking.)
- If you fill to the top of the fuel tank inlet, fuel might spill out from the tank, and it becomes dangerous
- After refueling, tighten the tank cap well.



## 4.3 Location And Ventilation Precautions

### **DANGER**

- Do not run the machine in an unventilated location, such as indoors or inside a tunnel. The exhaust gas from the engine contains toxic gases such as carbon monoxide and is very hazardous.
- Do not operate the machine near open flames.



## 4.4 Precautions Before Starting

### **CAUTION**

- Check each part to see if it is tightened properly. Vibration causes loosening of bolts, which results in unexpected serious malfunctions of the machine. Tighten the bolts securely.

## 4.5 Precautions During Work

### **CAUTION**

- Before starting the machine, make sure it is safe to start by checking your surroundings for people and objects.
- Always pay attention to your footing. Work in an area where you can maintain a good balance of the machine and a safe comfortable posture.
- The engine and muffler become very hot. Do not touch immediately after the machine stops because they are still very hot.
- If you notice deterioration of machine operation during your work, stop your work immediately.
- Before moving away from the machine, be sure to turn the engine off. Also when the machine is transported, stop the engine and close the fuel cock.
- For a machine with cell starter specification, do not operate without the battery. If you operate without the battery, electrical system failure might occur.



## 4.6 Lifting Precautions

### **DANGER**

- Before lifting, check the machine parts (especially the hook and shock absorbers) for any damage and loosened or missing bolts.
- Stop the engine and shut the fuel cock while lifting.
- Use a sufficiently strong wire rope.
- For lifting, use only one point hoisting hook, and do not lift at any other part.
- When the machine is hoisted, never let people or animals come underneath.
- For safety reasons, do not lift to a height that is higher than necessary.



## 4.7 Transportation And Storage Precautions

### **WARNING**

- Stop the engine during transportation.
- Transport after the engine and the machine are cooled down.
- Always drain the fuel before transporting.
- Securely fix the machine to prevent it from moving or falling during transportation.
- Do not store the machine on the place where it may be submerged.



## 4.8 Maintenance Precautions

### **WARNING**

- Appropriate maintenance is required to ensure safe and efficient operation of the machine. Always pay attention to the machine's condition and keep it in good condition. Pay special attention to the parts used for lifting, if they are not maintained properly, it might result in a serious accident.
- Start maintenance work after the machine has cooled down completely. The muffler, in particular, becomes very hot, and there is a danger of burn. The engine, engine oil and vibrator also become very hot. Be careful not to get burned.



### **CAUTION**

- Always stop the engine before inspection and adjustment. If you are caught in a rotating part, serious injury might occur.
- After maintenance work, check the security parts to see if they are securely installed. Special attention should be paid when checking bolts and nuts.
- If disassembly is involved in maintenance, refer to the maintenance instruction manual to make your work safe.



## About The Battery

### **DANGER**

- If the battery fixing bolts have been removed, put them back and tighten securely to fix the battery.  
If used with the battery not fixed properly, contact with the battery terminal might occur, leading to electric shock and electric leak, or breakage of the battery might occur by the impact and vibration from outside, resulting in battery fluid leakage.
- The gas from the battery might cause an explosion. Do not generate sparks or bring flames near the battery.
- Never put the positive terminal and negative terminal come into contact. Sparks will be generated, and ignition might occur.

### **WARNING**

- Be careful when handling the battery fluid because it is very toxic. If the battery fluid gets on your skin, eye, or clothes, rinse it off with plenty of water and consult with a doctor.

## 4.9 Decals Position And Descriptions Of Warning Decals

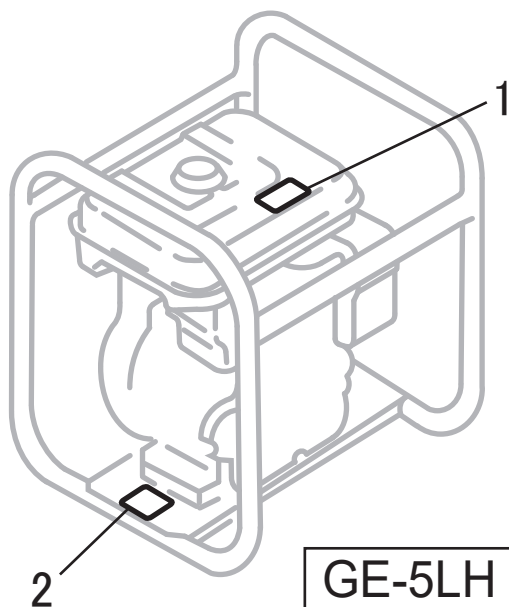

1: 9201-10700 DECAL CAUTION, FINGERTIP

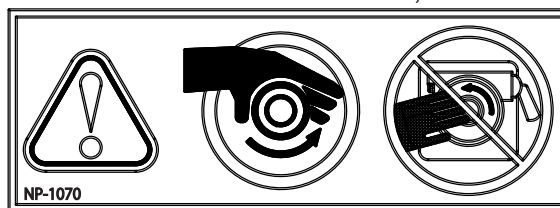

### Rotating Parts Hazard.

During operation, keep hands clear from all moving parts to prevent injury.

2: PLATE, SERIAL NO. /GE-5LH

## 5. SPECIFICATIONS

### 5.1 Machine Specifications

Model	GE-5LH	
Engine	Honda GX160	
Overall Length	mm	412
Overall Width	mm	442
Overall Height	mm	456
Operating Weight	kg	28.0
Set R.P.M	min <sup>-1</sup>	3,200

(The specifications may be changed without notice.)

### 5.2 Engine Specifications

Manufacturer	Honda
Model	GX160
Type	Air cooled 4 cycle slant type single cylinder gasoline engine
Displacement	163 cm <sup>3</sup>
Max Output	3.6kW/3600min <sup>-1</sup> (4.9PS/3600rpm)
Ignition method	Transistor type magnet ignition
Spark plug	NGK BP6ES
Fuel	Unleaded Automobile Gasoline
Fuel Tank Capacity	3.1 liters
Weight	15kg (33lbs.)

(The specifications may be changed without notice.)



## 6. APPEARANCE

### 6.1 Dimensions

#### GE-5LH

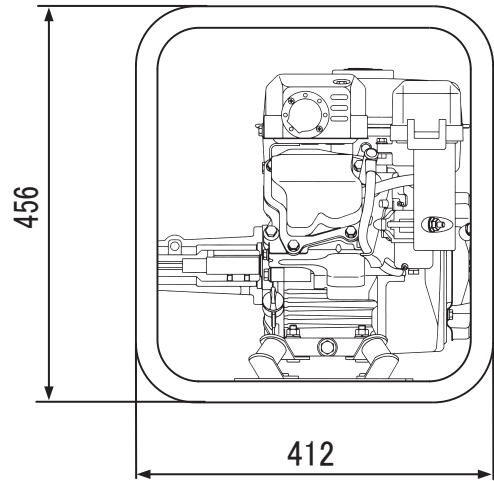
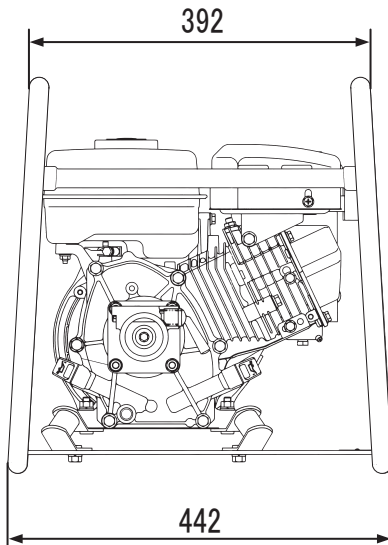

### 6.2 Components

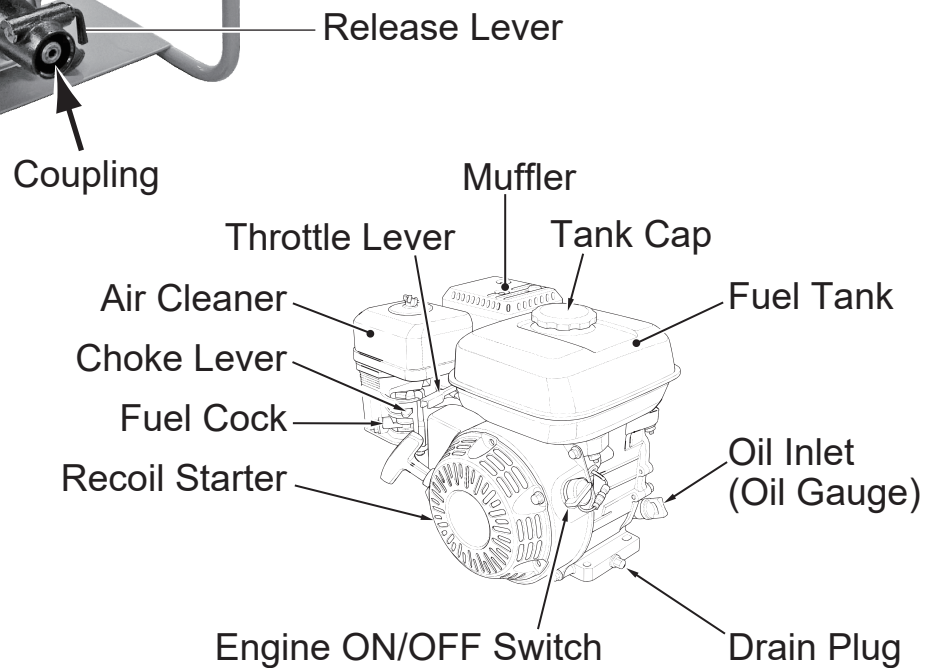
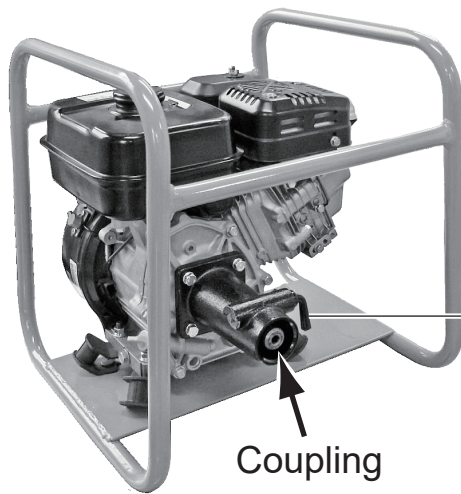

## 7. INSPECTION BEFORE OPERATION

### **CAUTION**

Always stop the engine before inspection and set the machine on hard and level ground.

### 7.1 Visual Inspection

Check each part for any looseness of bolts. Vibration causes bolts to loosen, which might result unexpected accident or malfunction.

### 7.2 Engine Oil

Check the oil level. If the oil level is low, fill oil. (Fig.1)

Use the following engine oil.

**Quality:** Gasoline engine oil, Grade SE or above  
**Viscosity:** SAE No. 30 at 20°C and above (summer)  
SAE10W-30

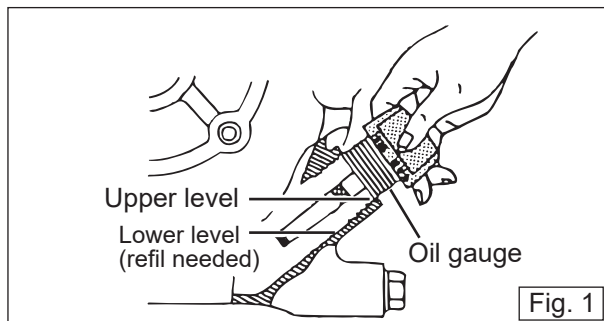

### 7.3 Refueling

#### **DANGER**

- Stop the engine when refueling.
- Never refueling near a naked flames or a source of sparks.
- Do not fill the fuel tank completely because the fuel might spill.
- Wipe up any spilled fuel.

### 7.3 Work Location

#### **CAUTION**

- Do not slant this product more than 10 degrees to any direction. Find a level surface with little unevenness where the machine can be stabilized. In case if this product falls over, accident such as fire might occur.
- Do not operate this product in rain or in the location where water might be splashed. There is a danger of spark induced fire.

## 8. OPERATION

### **CAUTION**

- When operating this product without attaching a flexible shaft, do not come close to the coupling part. Serious accident or injury might occur if fingers or clothes get caught.
- When attaching the flexible shaft to this drive unit, make sure that the engine is stopped. Serious injury might occur if you work with this product without stopping the engine.

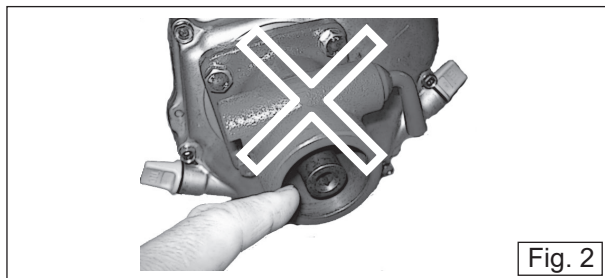

### 8.1 Starting

- 1 Connect the flexible shaft to the drive unit. To do so, turn the lever of the engine coupling, and insert the hexagonal joint and the hose coupling to it. Then, get the lever back into the original position. (Fig.3)

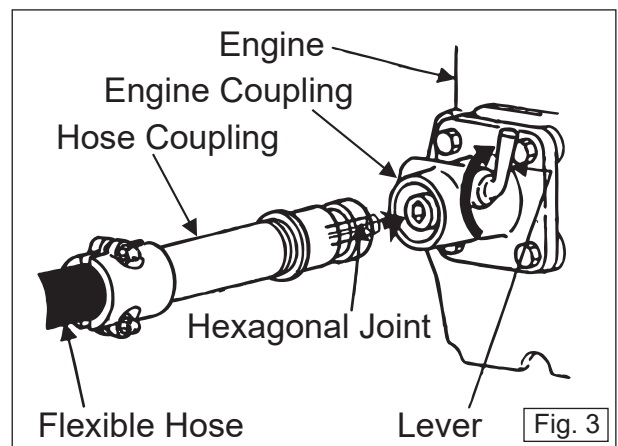

- 2 Move the fuel cock lever to the "ON" position. (Fig.4)

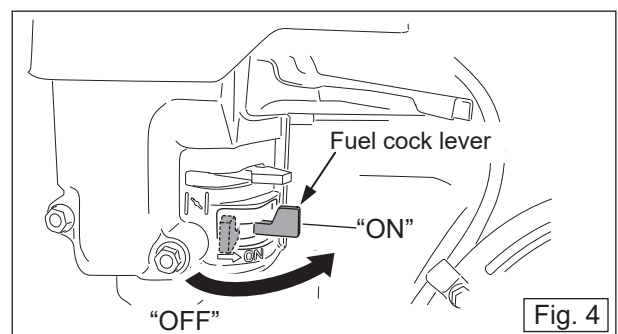

- To start a cold engine, move the choke lever to the "CLOSED" position. To restart a warm engine, leave the choke lever in the "OPEN" position. (Fig.5)

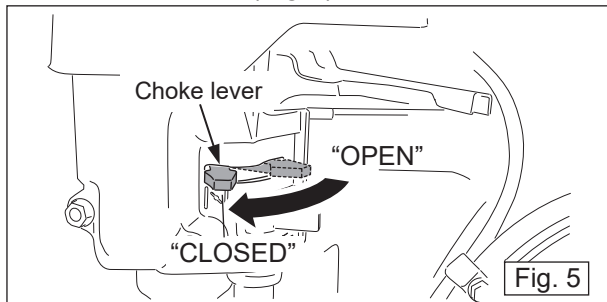

- Move the throttle lever from idle speed to operation speed and set it at about 1/3 open position. (Fig.6)

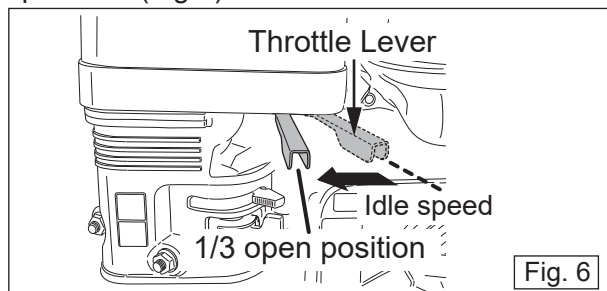

- Turn the engine switch to the "ON" position. (Fig.7)

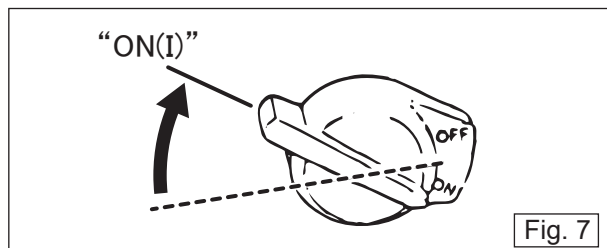

- Pull the starter grip lightly until you feel resistance. Then, pull it briskly in the direction of the arrow as shown below. (Fig.8)

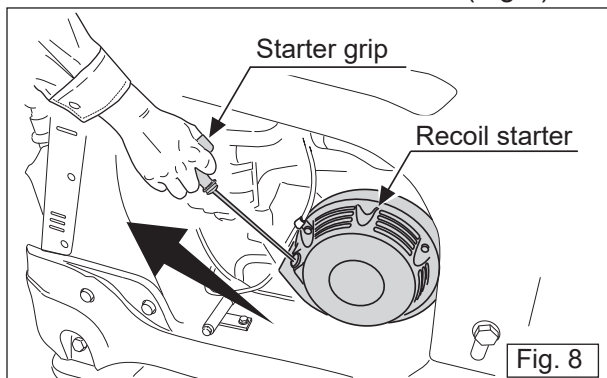

**CAUTION**

- Do not pull the starter grip all the length of the rope.
- Be careful not to pull it too hard as it might break or come off.
- Return it gently to prevent damage to the recoil starter.

- If the choke lever has been moved to the "CLOSED" position to start the engine, gradually move it to the "OPEN" position as the engine warms up. (Fig.9)

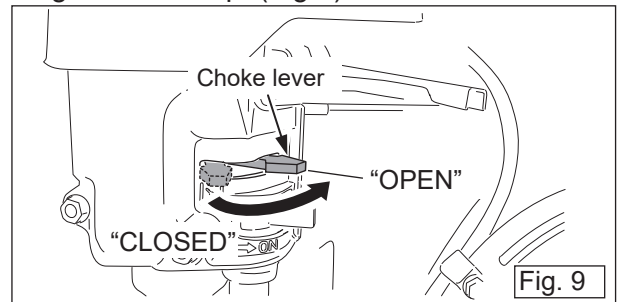

- After the engine has started, warm up the engine at idle speed for 2 to 3 minutes. This is especially important in cold weather. (Fig.10)

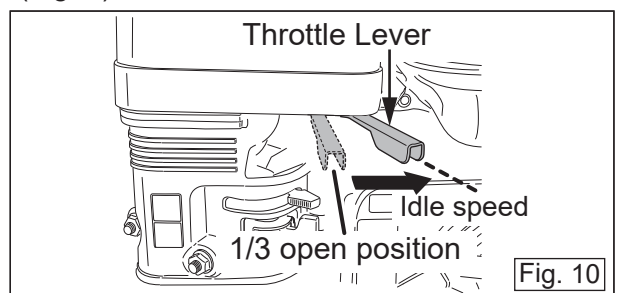

**8.2 Operation**

- Once the engine has started, move the throttle lever to the operation speed. (Fig.11)

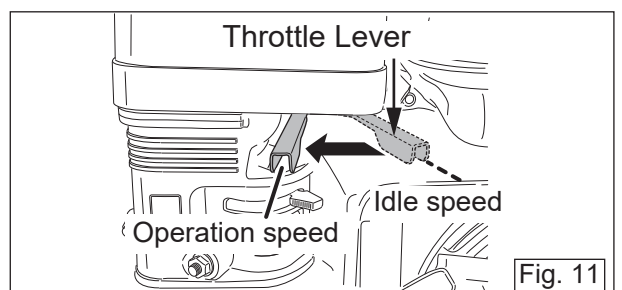

**CAUTION**

- The operation speed is adjusted to 3,200 rpm.
- Do not turn the stop screw of throttle lever to increase more than the operation speed, because failure might occur.

## 9. STOPPING THE MACHINE

### CAUTION

Never stop the engine suddenly while working at high speeds.  
It might cause engine failure.

- 1 Move the throttle lever to the idle position. Cool down the engine for 3 to 5 minutes at idle speeds before stopping. (Fig.12)

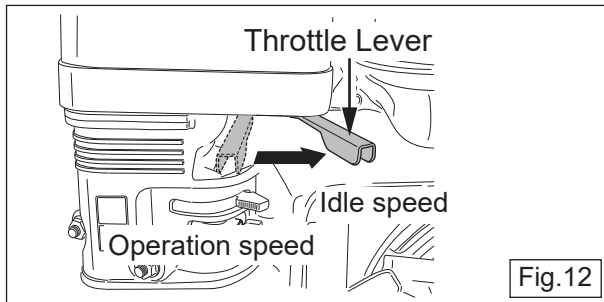

- 2 Turn the engine switch to the "OFF" position. (Fig.13)

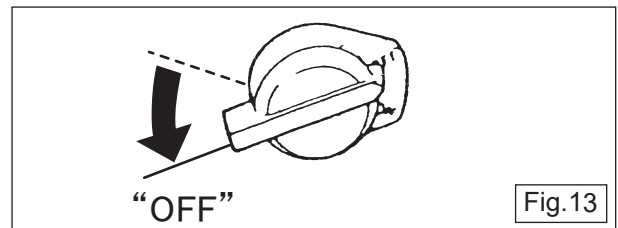

- 3 Move the fuel cock lever to the "OFF" position. (Fig.14)

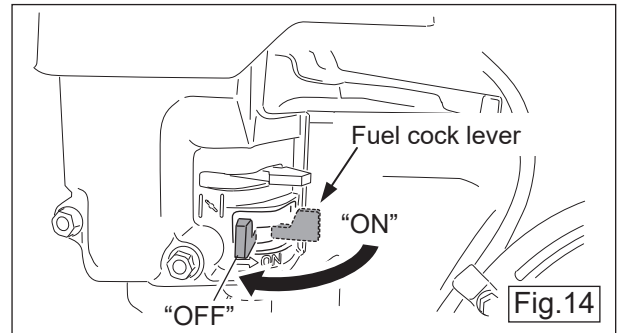

## 10. STORAGE

- Wash with water to remove any dust and dirt from all parts of the machine.
- Store in a dry area away from direct sunlight after putting the cover over the machine to prevent dust and dirt buildup.

In case of storing this machine for an extended period of time.

- Drain the fuel from the fuel tank, fuel pipe, and carburetor completely.
- Conduct to refill or change the oil without omission.
- Remove the spark plug, put a few drops of engine oil into the cylinder, and rotate the engine manually for spreading the oil inside sufficiently.
- Securely cover the air cleaner inlet and the muffler exhaust port.
- Do not leave the machine outdoors. Keep it indoors.
- Do not store this machine by overturning.

## 11. INSPECTION AND MAINTENANCE

### 11.1 Inspection And Maintenance Schedule

Inspection interval	Inspection parts	Inspection items	Remarks
Daily (before starting operation)	Appearance	Deformation, Breakage	
	Fuel tank	Leakage, Fuel level, Dirt	Gasoline
	Fuel system	Leakage	
	Engine oil	Leakage, Oil level, Dirt	Engine oil
	Air cleaner	Dust, Dirt	
	Guard frame	Deformation, Breakage	
	Bolts and nuts	Looseness, missing	
After first 20 hours	Engine oil	Change once after the first 20 hours.	Engine oil
Every 50 hours	Air cleaner	Cleaning	
Every 100 hours	Engine oil	Change	Engine oil
Every 2 years	Fuel pipes	Change	
As needed.	Air cleaner element	Change	

For details about the inspection and maintenance of the engine, please refer to the attached engine operation manual.

Caution: The above table shows the inspection interval under normal condition.

The inspection interval may vary depending on the condition in which the machine is used.

For check of bolt and nut looseness and tightening, please see the following tightening torque list.

#### Tightening torque list (unit: kgf-cm, 1kgf-cm=9.80665N-cm)

		Thread diameter							
		6mm	8mm	10mm	12mm	14mm	16mm	18mm	20mm
Material	4T(SS400)	70	150	300	500	750	1,100	1,400	2,000
	6-8T(S45C)	100	250	500	800	1,300	2,000	2,700	3,800
	11T(SCM435)	150	400	800	1,200	2,000	2,900	4,200	5,600
	When the mating material is aluminum.	100	300~350	650~700	(Bolts used on the machine are all right-hand thread.)				

## 12. TROUBLESHOOTING

### (1) Starting problems

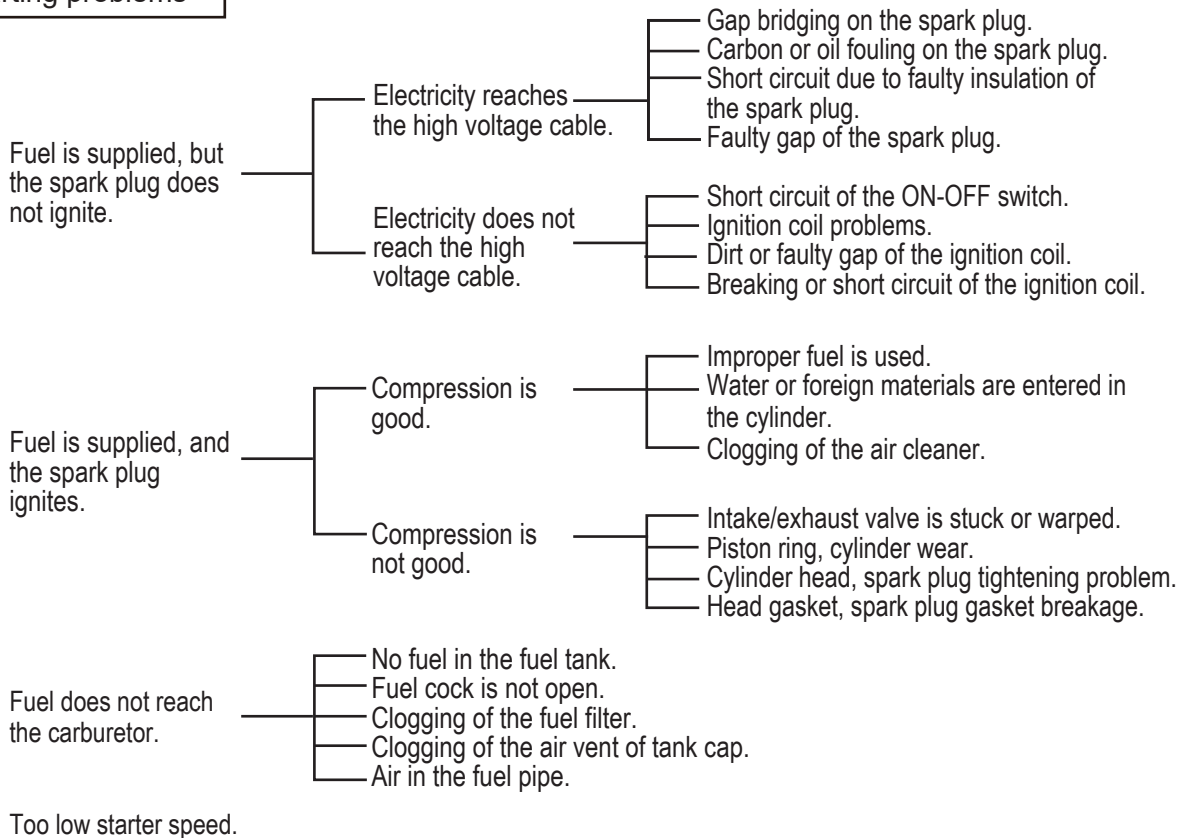

### (2) Operation problems

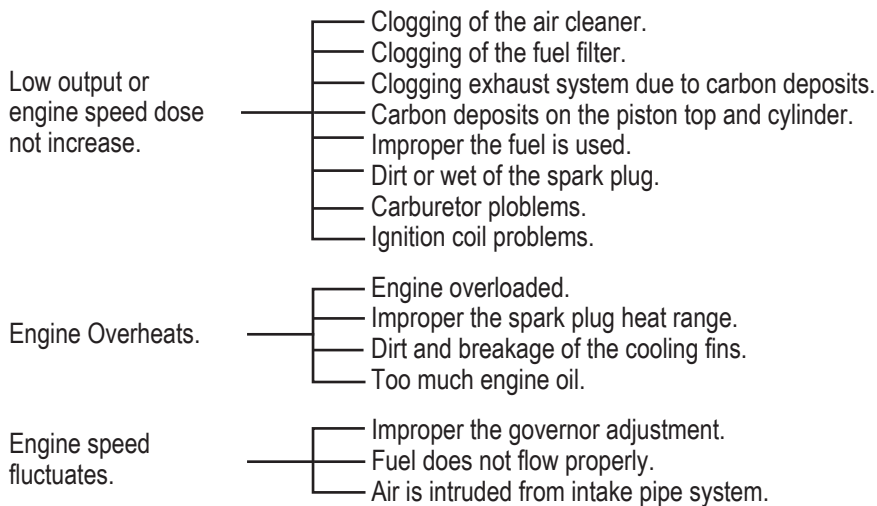

### (3) Recoil starter problems

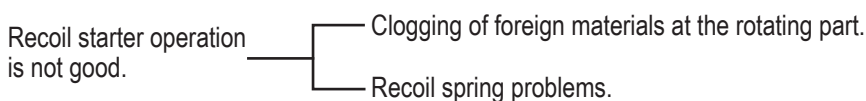



*Mikasa*

MIKASA SANGYO CO., LTD.

1-4-3, Kanda-Sarugakucho, Chiyoda-ku, Tokyo, 101-0064, Japan

PRINTED IN JAPAN